



HAL
open science

Satellites galiléens de Jupiter : phénomènes et configurations pour 2012, suivis d'une méthode permettant de calculer les phénomènes pour 2013

S. Lemaître, Ch. Ruatti

► **To cite this version:**

S. Lemaître, Ch. Ruatti. Satellites galiléens de Jupiter : phénomènes et configurations pour 2012, suivis d'une méthode permettant de calculer les phénomènes pour 2013. [Rapport de recherche] Institut de mécanique céleste et de calcul des éphémérides(IMCCE). 2012, 73 p.,figures, tableaux. hal-01467413

HAL Id: hal-01467413

<https://hal-lara.archives-ouvertes.fr/hal-01467413v1>

Submitted on 14 Feb 2017

HAL is a multi-disciplinary open access archive for the deposit and dissemination of scientific research documents, whether they are published or not. The documents may come from teaching and research institutions in France or abroad, or from public or private research centers.

L'archive ouverte pluridisciplinaire **HAL**, est destinée au dépôt et à la diffusion de documents scientifiques de niveau recherche, publiés ou non, émanant des établissements d'enseignement et de recherche français ou étrangers, des laboratoires publics ou privés.

SATELLITES GALILÉENS DE JUPITER
PHÉNOMÈNES ET CONFIGURATIONS POUR 2012
SUIVIS D'UNE MÉTHODE PERMETTANT DE CALCULER LES
PHÉNOMÈNES POUR 2013



Supplément à la **CONNAISSANCE DES TEMPS**
à l'usage des observateurs



Institut de Mécanique Céleste et de Calcul des Éphémérides

Institut de mécanique céleste et de calcul des éphémérides
UMR 8028 du CNRS – Observatoire de Paris

SATELLITES GALILÉENS DE JUPITER

GALILEAN SATELLITES OF JUPITER

PHÉNOMÈNES ET CONFIGURATIONS POUR 2012, SUIVIS D'UNE
MÉTHODE PERMETTANT DE CALCULER LES PHÉNOMÈNES POUR 2013

PHENOMENA AND CONFIGURATIONS FOR 2012, FOLLOWED BY A
METHOD FOR THE CALCULATION OF THE PHENOMENA FOR 2013

Supplément à la CONNAISSANCE DES TEMPS
à l'usage des observateurs



Institut de Mécanique Céleste et de Calcul des Éphémérides

Institut de mécanique céleste et de calcul des éphémérides
UMR 8028 du CNRS – Observatoire de Paris

ISSN 0769 – 1033

Dépôt légal : Janvier 2012

**LES SERVEURS SUR INTERNET
DE L'INSTITUT DE MÉCANIQUE CÉLESTE
ET DE CALCUL DES ÉPHÉMÉRIDES**

<http://www.imcce.fr> et <ftp://ftp.imcce.fr>

L'Institut de mécanique céleste et de calcul des éphémérides diffuse de nombreuses informations, périodiquement remises à jour, grâce à son serveur sur le réseau Internet. Outre des informations générales sur l'histoire et les activités de l'Institut de mécanique céleste et de calcul des éphémérides, on peut y trouver des données scientifiques concernant les objets du système solaire :

- éphémérides de planètes et de satellites, phénomènes ;*
- données sur les objets du système solaire ;*
- éléments orbitaux de comètes, de planètes naines et d'astéroïdes ;*
- données sur les éclipses du Soleil et de Lune ;*
- bases de données astrométriques ;*
- images astronomiques.*

Un serveur WEB est accessible à l'adresse <http://www.imcce.fr>. Un serveur ftp anonyme est accessible à l'adresse: <ftp://ftp.imcce.fr>.

***THE INTERNET SERVERS
OF THE INSTITUT DE MÉCANIQUE CÉLESTE
ET DE CALCUL DES ÉPHÉMÉRIDES***

<http://www.imcce.fr> and <ftp://ftp.imcce.fr>

The Institut de mécanique céleste et de calcul des éphémérides publishes information thanks to Internet servers. Besides general information concerning history and activities of the Institut de mécanique céleste et de calcul des éphémérides, one may access scientific data on:

- ephemerides of planets and satellites, phenomena;*
- data on the objects of the Solar system;*
- orbital elements of comets, dwarf planets and asteroids;*
- data on solar and Lunar eclipses;*
- astrometric data base;*
- astronomical images.*

The address of the WEB Server is: <http://www.imcce.fr>. One can also access an anonymous ftp server at the address: <ftp://ftp.imcce.fr>.

**PUBLICATIONS DE L'INSTITUT DE MÉCANIQUE CÉLESTE
ET DE CALCUL DES ÉPHÉMÉRIDES**

(Bureau des longitudes - Observatoire de Paris)

Publications éditées par EDP Sciences,

17, avenue du Hoggar, Z.I. de Courtabœuf, B.P. 112, F-91944 Les Ulis Cedex A

Éphémérides astronomiques 2012 - Connaissance des Temps - (avec un CDROM).

Annuaire du Bureau des longitudes 2012.

Introduction aux éphémérides astronomiques. Supplément explicatif à la Connaissance des Temps, épuisé.

Les éclipses de Soleil. L'éclipse totale du 11 août 1999.

Le passage de Vénus.

Le guide des éclipses.

Publications éditées par Edinautic,

13, rue du Vieux Colombier, F-75006 Paris

Éphémérides Nautiques 2012.

Publications éditées par Dunod,

5, rue Laromiguière, F-75006 Paris

Cahiers des Sciences de l'Univers, publiés sous l'égide du Bureau des longitudes.

Les profondeurs de la Terre par J.-P. Poirier (1991).

Stratosphère et couche d'ozone par G. Mégie (1992).

Chronique de l'espace-temps – Du vide quantique à l'expansion cosmique par:

A. Mazure, G. Mathez, Y. Mellier (1994).

Les fondements de la mesure du temps par Cl. Audoin, B. Guinot (1998).

Publications éditées par l'Institut de mécanique céleste et de calcul des éphémérides,

CNRS – Bureau des longitudes, Service des ventes, 77, avenue Denfert-Rochereau, F-75014 Paris

Suppléments à la Connaissance des Temps.

Satellites galiléens de Jupiter. Phénomènes et configurations.

Satellites de Saturne I à VIII. Configurations.

Le calendrier républicain (réédition, 1994).

Notes scientifiques et techniques de l'Institut de Mécanique Céleste et de Calcul des éphémérides.

Encyclopédie scientifique de l'univers.

La physique (1981).

La Terre, les eaux, l'atmosphère (réédition, 1984), épuisé

Les étoiles, le système solaire (réédition, 1986).

La galaxie, l'univers extragalactique (réédition, 1988).

L'astronomie au service de tous (2009)

L'observatoire de la marine et du Bureau des longitudes au parc Montsouris, 1875-1914 (par Guy Boistel), co-édition Edite, 2010

Table des matières	Page
<i>Avertissement</i>	7
<i>Données sur les satellites galiléens</i>	9
<i>Théorie du mouvement des satellites galiléens</i>	10
<i>Présentation des éphémérides</i>	11
<i>Phénomènes et configurations pour 2012</i>	17
<i>Phénomènes pour 2013</i>	67

Table of contents	Page
<i>Foreword</i>	7
<i>Data on the Galilean satellites</i>	9
<i>Theory of the motion of the Galilean satellites</i>	10
<i>Presentation of the ephemerides</i>	11
<i>Phenomena and configurations for 2012</i>	17
<i>Phenomena for 2013</i>	67

Avertissement

À partir de 1996, des éphémérides des satellites naturels ont été publiées dans la *Connaissance des Temps*. Un CDROM accompagne cet ouvrage. Ces éphémérides donnent les positions des satellites de Mars, des satellites galiléens de Jupiter, des huit premiers satellites de Saturne et des cinq satellites d'Uranus avec une précision proche de celle des théories originales.

Cependant, des observateurs ont souhaité continuer à disposer d'un ouvrage permettant d'identifier les satellites galiléens et de connaître les instants des phénomènes présentés par ces satellites et calculés à une seconde de temps près. En particulier, les configurations précises permettent très facilement de situer les satellites avec une précision de $10''$ par rapport à Jupiter.

On trouvera aussi des renseignements généraux sur les satellites galiléens en début d'ouvrage ainsi qu'une méthode de calcul des phénomènes pour l'année suivante en fin d'ouvrage.

Foreword

Starting from 1996, ephemerides of natural satellites have been published in the *Connaissance des Temps*. A CDROM is available. These ephemerides give the positions of the satellites of Mars, of the Galilean satellites of Jupiter, of the first eight satellites of Saturn and of the five satellites of Uranus involving secular and periodic terms and depending directly on time. The accuracy is near that of the original theories.

However, observers wish to keep ephemerides allowing to identify immediately the Galilean satellites and to know the dates of the phenomena which are calculated to the nearest second of time. This is given by the present booklet, particularly the configurations giving positions with an accuracy of $10''$ relatively to Jupiter.

Besides these informations, the present booklet gives various data concerning the Galilean Satellites. We also present a method which permits the calculation of the phenomena for the next year.

J.-E. Arlot

W. Thuillot

Responsables de la publication

Rédaction et calculs : S. Lemaître, Ch. Ruatti.

DONNÉES SUR LES SATELLITES GALILÉENS
DATA ON THE GALILEAN SATELLITES

	IO (I)	EUROPE (II)	GANYMÈDE (III)	CALLISTO (IV)
<i>Masses</i> (10^{-5} masse de Jupiter)				
Sampson (1921)	4.50	2.54	7.99	4.50
De Sitter (1931)	3.81	2.48	8.17	5.09
Pioneer 11 (1976)	4.68	2.52	7.80	5.66
Fukushima (1990)	4.705	2.525	7.803	5.667
Lainey et al. (2004)	4.701	2.253	7.805	5.667
<i>Rayons</i> (km)				
Danjon (1954)	1650	1400	2450	2300
Dollfus (1961)	1775	1550	2800	2525
Pioneer 11 (1976)	1840	1552	2650	2420
Davies et al. (1996)	1821	1565	2634	2403
<i>Magnitudes visuelles</i> <i>l'opposition de Jupiter</i>				
Harris (1961)	4.8	5.2	4.5	5.5
<i>Albédos géométriques</i> (Harris, 1961)				
U : 353 nm	0.19	0.47	0.29	0.14
B : 448 nm	0.56	0.67	0.41	0.21
V : 554 nm	0.92	0.83	0.49	0.26
R : 690 nm	1.12	0.93	0.56	0.30
I : 820 nm	1.15	0.95	0.57	0.31
<i>Albédo de Bond</i> (visuel)				
	0.54	0.49	0.29	0.15
<i>Demi-grand axe</i> Lainey et al. (2004)				
en UA	0.002 821	0.004 487	0.007 157	0.012 588
en rayons de Jupiter	5.91	9.41	15.00	26.22
en kilomètres	422 030	671 261	1 070 621	1 883 133
<i>Plus grande élongation</i> <i>l'opposition de Jupiter</i> (minutes et secondes de degré)				
Lainey et al. (2004)	2'17"	3'40"	5'48"	10'13"
<i>Période synodique</i> (jours)				
Lainey et al. (2004)	1.769 137 774 4	3.551 181 063 6	7.154 553 197 0	16.689 017 417 0
<i>Inclinaison moyenne sur</i> <i>l'équateur de Jupiter pour 2012.5</i> (degré)				
Lainey et al. (2004)	0.0467°	0.4834°	0.1448°	0.2377°
<i>Valeur moyenne de l'excentricité</i> <i>pour 2012.5</i>				
Lainey et al. (2004)	0.0042	0.0093	0.0019	0.0073
<i>Partie séculaire du mouvement</i> (degré par an)				
nœud	-48.448	-11.911	-2.614	-0.640
périjove	55.754	14.188	2.664	0.671
Lainey et al. (2004)				

**THÉORIE DU MOUVEMENT
DES SATELLITES GALILÉENS**

**THEORY OF THE MOTION OF
THE GALILEAN SATELLITES**

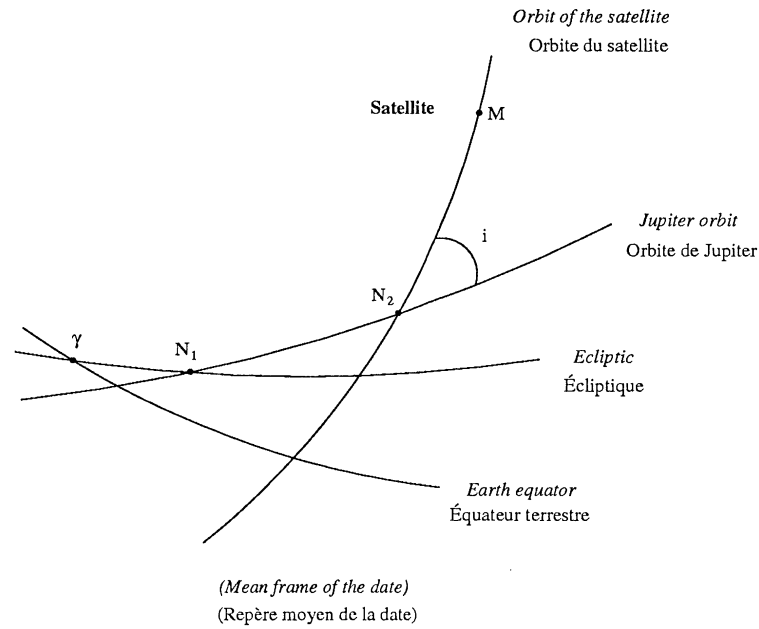

Du fait de la complexité du mouvement des satellites galiléens, il est difficile de donner des valeurs précises pour les nœuds et les périjoves. En effet, les excentricités et les inclinaisons sont faibles (cf. tableau précédent) et tous ces éléments sont soumis à de grandes variations (Thuillot, Vu, 1985).

Because of the complexity of the motion of the Galilean Satellites of Jupiter it is difficult to provide precise values for nodes and perijoves. Indeed, eccentricities and inclinations are small (see the preceding table) and all these elements undergo large variations (Thuillot, Vu, 1985).

On donne ci-après les longitudes moyennes (d'après Sampson, 1921) dans le plan des orbites, ce plan étant confondu avec l'équateur de Jupiter.

The mean longitudes (Sampson, 1921) in the orbital planes identified with Jupiter's equator are given below.

Si τ est le temps en jours moyens compté à partir de 1900,0 on a :

If τ is the time in days which has elapsed from 1900.0, one gets:

$\gamma N_1 N_2 = 316^\circ.051 + 0.000\,035\,59 \tau$, $i = 3^\circ.10350$			
	$\gamma N_1 + N_1 N_2 + N_2 M =$		Période sidérale en jours Sidereal period in days
Io	42° .599 87	+ 203.488 992 435 τ	1.769 137 463 9
Europe	99° .550 81	+ 101.374 761 672 τ	3.551 179 742 0
Ganymede	168° .026 28	+ 50.317 646 290 τ	7.154 547 689 4
Callisto	234° .407 90	+ 21.571 109 630 τ	16.688 988 474 6

PRÉSENTATION DES ÉPHÉMÉRIDES
PRESENTATION OF THE EPHEMERIDES

ÉCHELLES DE TEMPS

L'argument "temps" des éphémérides publiées ici est le TT (temps terrestre) proche du TE (temps des éphémérides) et réalisé physiquement par la mesure du TAI (temps atomique international). On a :

$$TT = TAI + 32,184 \text{ s}$$

Les événements astronomiques étant mesurés dans l'échelle UTC (temps universel coordonné), le tableau ci-dessous donne la relation entre TT et UTC (d'après la relation entre TAI et UTC publiée par l'IERS).

	<i>TT - UTC</i>
du 1 juillet 1997 au 1 janvier 1999	63,184 s
du 1 janvier 1999 au 31 décembre 2005	64,184 s
du 1 janvier 2006 au 31 décembre 2008	65,184 s
Depuis le 1 janvier 2009	66,184 s

**PHÉNOMÈNES DES SATELLITES
GALILÉENS**

Les hypothèses utilisées pour le calcul des époques des phénomènes (Thuillot, 1989) sont les suivantes :

- *Jupiter est un ellipsoïde dont l'aplatissement a pour valeur 1/15,4 et dont le rayon équatorial est 71 492 km.*

- *Les satellites sont des sphères de rayon : 1821 km pour Io, 1565 km pour Europe, 2634 km pour Ganymède, 2403 km pour Callisto (Davies et al., 1996).*

- *Le Soleil est une sphère de rayon 695 980 km.*

- *Les dates sont données pour tout observatoire terrestre puisqu'on peut négliger l'effet de parallaxe dont la grandeur est plus faible que la précision des prédictions.*

TIME-SCALES

The time argument of the ephemerides is TT (terrestrial time) close to the former definition of ET (ephemeris time) and physically made by measuring TAI (international atomic time), so that :

$$TT = TAI + 32.184 \text{ s}$$

Astronomical events are measured in the time-scale UTC (coordinate universal time). The table below gives the correspondence between TTT and UTC (using the relationship between TAI and UTC published by IERS).

	<i>TT - UTC</i>
<i>From July 1, 1997 to December 31, 1999</i>	<i>63,184 s</i>
<i>From January 1, 1999 to December 31, 2005</i>	<i>64,184 s</i>
<i>From January 1, 2006 to December 31, 2008</i>	<i>65,184 s</i>
<i>Since January 1, 2009</i>	<i>66,184 s</i>

**PHENOMENA OF THE GALILEAN
SATELLITES**

The hypothesis made for the calculations of the dates of the phenomena (Thuillot, 1989) are :

- *Jupiter is an ellipsoid the flatness of which is 1/15,4 and the equatorial radius of which is 71 492 km.*

- *The satellites are spheres the radius of which are : 1821 km for Io, 1565 km for Europe, 2634 km for Ganymede and 2403 km for Callisto (Davies et al., 1996).*

- *The Sun is a sphere the radius of which is 695 980 km.*

- *The dates are given for everywhere on Earth since no parallax effect has to be taken into account.*

L'effet de phase est négligé pour les satellites, mais pris en compte pour la planète.

Les pages paires fournissent les dates des phénomènes que présentent ces satellites :

- les débuts et fins des passages des satellites devant la planète :

*PA.D.INT et PA.D.EXT
PA.F.INT et PA.F.EXT*

- les débuts et fins de leurs occultations (anciennement appelées immersions et émergences) :

*OC.D.INT et OC.D.EXT
OC.F.INT et OC.F.EXT*

- les débuts et fins des passages de leur ombre sur Jupiter :

*OM.D.INT et OM.D.EXT
OM.F.INT et OM.F.EXT*

- les débuts et fins des éclipses des satellites par Jupiter :

*EC.D.INT, EC.D.EXT, EC.D.PEN
EC.F.INT, EC.F.EXT, EC.F.PEN*

Les notations utilisées sont les suivantes :

- .D et .F désignent le début et la fin.

- .INT désigne les contacts intérieurs des satellites avec le cône d'ombre pour les éclipses et les passages des ombres sur Jupiter, et désigne les mêmes contacts avec le cône de visibilité pour les occultations et les passages devant la planète.

- .EXT désigne les contacts extérieurs des satellites avec le cône d'ombre pour les éclipses et les passages des ombres sur Jupiter, et désigne les mêmes contacts avec le cône de visibilité pour les occultations et les passages devant la planète.

- .PEN désigne uniquement pour les éclipses, le contact extérieur des satellites avec le cône de pénombre.

The phase defect is neglected on the satellites but taken into account for Jupiter.

Even pages give the dates of the phenomena :

- the beginnings and the ends of the transits of the satellites in front of Jupiter :

*PA.D.INT and PA.D.EXT
PA.F.INT and PA.F.EXT*

- the beginnings and the ends of the occultations of the satellites by Jupiter :

*OC.D.INT and OC.D.EXT
OC.F.INT and OC.F.EXT*

- the beginnings and the ends of the transits of the umbra of the satellites on the disk of Jupiter :

*OM.D.INT and OM.D.EXT
OM.F.INT and OM.F.EXT*

- the beginnings and the ends of the eclipses of the satellites by Jupiter :

*EC.D.INT, EC.D.EXT, EC.D.PEN
EC.F.INT, EC.F.EXT, EC.F.PEN*

The notations means :

- .D and .F mean beginning and end.

- .INT means :

*· interior contact satellite/shadow cone for the eclipses and transits of shadows on Jupiter,
· interior contact satellite/cone of visibility for the occultations and the transits.*

- .EXT means :

*· exterior contact satellite/shadow cone for the eclipses and transits of shadows on Jupiter,
· exterior contact satellite/cone of visibility for the occultations and the transits.*

- .PEN means exterior contact satellite/penumbra cone for the eclipses.

EXEMPLE

Le déroulement d'un début d'éclipse se fait ainsi :

- *EC.D.PEN* : contact extérieur du satellite avec le cône de pénombre (début de l'assombrissement).
- *EC.D.EXT* : contact extérieur avec le cône d'ombre.
- *EC.D.INT* : contact extérieur avec le cône d'ombre (assombrissement total).

On observera que les éclipses se produisent à l'ouest ou à l'est de la planète, suivant que l'on est avant ou après l'opposition. En général pour le premier et le deuxième satellite, on ne peut, avant l'opposition, observer que le début des éclipses suivi de la fin des occultations. Après l'opposition on ne peut observer que le début des occultations suivi de la fin des éclipses. Il est possible, d'autre part, que, en raison de l'inclinaison de l'équateur de Jupiter sur l'écliptique et de l'éloignement du satellite IV Callisto par rapport à la planète, aucun phénomène de ce satellite ne se produise.

EXAMPLE

A beginning of an eclipse occurs as follows :

- *EC.D.PEN* : external contact of the satellite with the cone of penumbra (beginning of the penumbra).
- *EC.D.EXT* : external contact with the shadow cone.
- *EC.D.INT* : internal contact with the shadow cone (the satellite has disappeared in the umbra).

Note that the eclipses occur west of the planet before the opposition. Most of time for the first and the second satellite, only the beginning of the eclipse followed by the end of the occultation are observable. On the other hand, it may happen that no phenomenon occurs for satellite IV because it is far from Jupiter and because of the inclination of the equator of Jupiter above the ecliptic.

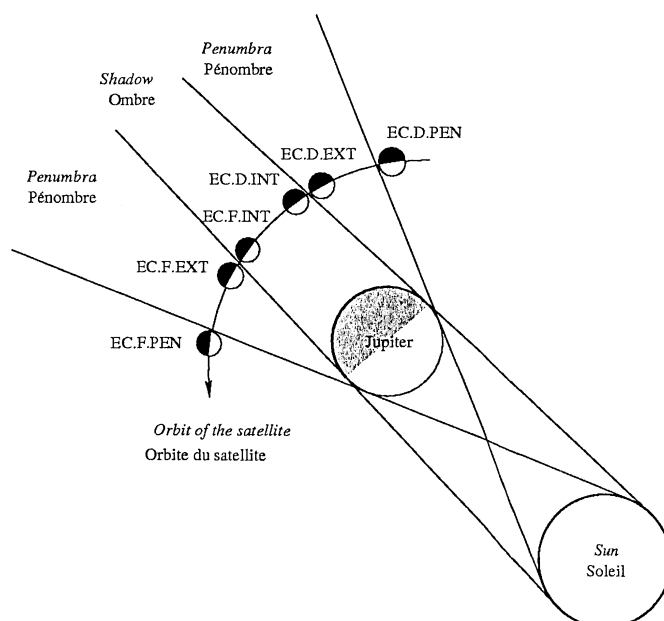

LES CONFIGURATIONS

Les configurations permettent d'identifier les satellites, et également de déterminer leur position en coordonnées tangentielles équatoriales relatives à Jupiter avec la précision suivante (pour une lecture des courbes à 0,5 mm près):

- Satellite 1: de 5'' à 20'' selon la vitesse apparente
- Satellite 2: de 5'' à 10'' selon la vitesse apparente
- Satellites 3 et 4: 5''

L'exemple suivant montre comment déterminer les positions des satellites:

On reporte en abscisse sur l'axe ouest-est les distances $\Delta\alpha \cos \delta$ mesurées pour une date voulue, sur les courbes. L'ordonnée est donnée par les orbites apparentes. L'indétermination avant/arrière est levée grâce au sens de rotation des satellites.

THE CONFIGURATIONS

The configurations permit to identify the satellites and to approach their positions relative to Jupiter in an equatorial tangential frame with the following precision (corresponding to a measure on the curves with an accuracy of 0,5 millimeter).

- Satellite 1: from 5'' to 20'' depending on the apparent velocity
- Satellite 2: from 5'' to 10'' depending on the apparent velocity
- Satellites 3 and 4: 5''

The following example shows how to determine the positions of the satellites:

For the abscissae, we have to project the differential coordinate $\Delta\alpha \cos \delta$ measured on the curves for a determined date on the East-West axis. For the ordinates, we have to project these abscissae on the apparent orbits as indicated on the figure. The front/back indetermination is removed thanks to the direction of the rotation of the satellites.

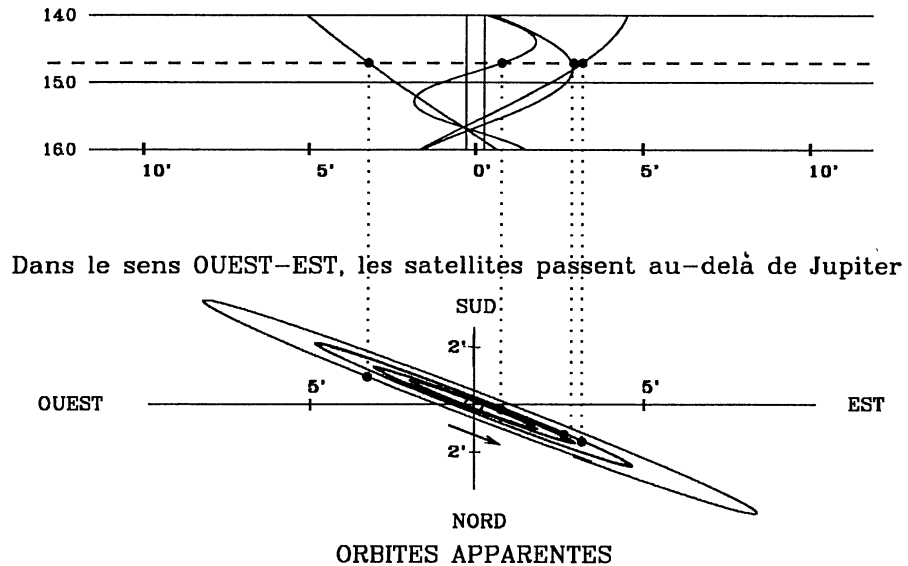

CALCULS DES PHÉNOMÈNES POUR 2013

Les prédictions des phénomènes des satellites galiléens sont données suivant une représentation polynomiale en fonction d'une variable temporelle. La méthode (Thuillot, 1983) permet une représentation compacte puisque moins de 13 coefficients suffisent à représenter chaque type de phénomène (passages, occultations, éclipses, passages d'ombre, débuts ou fins) de chaque satellite pour une année entière avec une précision de l'ordre de la minute de temps.

Des explications sur cette méthode, le formulaire et les tables de coefficients sont données pages 74 à 76.

CALCULATIONS OF THE DATES OF THE PHENOMENA FOR 2013

The predictions of the phenomena of the Galilean Satellites are given as a polynomial representation which depends directly on time. The method (Thuillot, 1983) allows a compact representation as less than 13 coefficients are sufficient to represent each type of phenomenon (transits, occultations, eclipses, shadow transits, beginnings or ends) for each satellite for a complete year with an accuracy of about one minute of time.

Some explanations about the method, the formulae and the tables of coefficients are given on pages 74 to 76.

RÉFÉRENCES

- Arlot, J.-E. : 1982, *Astron. Astrophys.* **107**, 305.
- Davies, M.E., Abalakin, V.K., Bursa, M., Lieske, J.H., Morando, B., Morrison, D., Seidelmann, P.K., Sinclair, A.T., Yallop, B., Tjuflin, Y.S. : 1996, Report of the IAU/IAG/COSPAR working group on cartographic coordinates and rotational elements of the planets and satellites: 1994, *Celest. Mech. Dyn. Astron.* **63**, 127.
- Lainey, V, Duriez, L, Vienne, A: 2004, *Astron. Astrophys.* **420**, 1171.
- Lainey, V, Arlot, J-E, Vienne, A: 2004 *Astron. Astrophys.* **427** , 371.
- Lieske, J.H. : 1977, *Astron. Astrophys.* **56**, 333.
- Sampson, R.A. : 1921, *Mem. Roy. Astron. Soc.* **63**.
- Thuillot, W. : 1983, *Astron. Astrophys.* **127**, 63.
- Thuillot, W., Vu, D.T. : 1985, *Note Scientifique et Technique du Bureau des Longitudes* **S009**.
- Thuillot, W. : 1989, *Note Scientifique et Technique du Bureau des Longitudes* **S015**.

ÉPHÉMÉRIDES

**PHÉNOMÈNES ET CONFIGURATIONS
POUR 2012**

EPHEMERIDES

**PHENOMENA AND CONFIGURATIONS
FOR 2012**

2012 - PHÉNOMÈNES DES SATELLITES GALILÉENS DE JUPITER
(Temps Terrestre)

JANVIER - PREMIÈRE QUINZAINE																		
jour	h	m	s	SAT.	TYPE	jour	h	m	s	SAT.	TYPE	jour	h	m	s	SAT.	TYPE	
0	10	37	11	III	OC.D.EXT		6	15	23	I	OM.F.INT		4	48	33	III	PA.D.INT	
	10	52	4	III	OC.D.INT		6	19	12	I	OM.F.EXT		6	23	59	II	PA.D.EXT	
	12	41	56	III	OC.F.INT		22	20	22	II	OC.D.EXT		6	28	23	II	PA.D.INT	
	12	56	49	III	OC.F.EXT		22	24	55	II	OC.D.INT		6	40	7	III	PA.F.INT	
	14	37	56	II	PA.D.EXT								6	54	43	III	PA.F.EXT	
	14	42	22	II	PA.D.INT	6	0	3	14	I	OC.D.EXT		7	28	5	I	OC.D.EXT	
	15	45	21	III	EC.D.PEN		0	7	0	I	OC.D.INT		7	31	51	I	OC.D.INT	
	15	51	5	III	EC.D.EXT		0	51	46	II	OC.F.INT		8	52	2	II	PA.F.INT	
	16	8	45	III	EC.D.INT		0	56	19	II	OC.F.EXT		8	56	28	II	PA.F.EXT	
	16	39	3	I	OC.D.EXT		1	0	47	II	EC.D.PEN		9	0	33	II	OM.D.EXT	
	16	42	49	I	OC.D.INT		1	2	39	II	EC.D.EXT		9	5	6	II	OM.D.INT	
	17	5	27	II	PA.F.INT		1	7	23	II	EC.D.INT		10	0	16	III	OM.D.EXT	
	17	6	24	II	OM.D.EXT		3	27	48	II	EC.F.INT		10	16	41	III	OM.D.INT	
	17	9	55	II	PA.F.EXT		3	30	2	I	EC.F.INT		10	56	33	I	EC.F.INT	
	17	10	58	II	OM.D.INT		3	32	32	II	EC.F.EXT		11	0	21	I	EC.F.EXT	
	17	35	40	III	EC.F.INT		3	33	50	I	EC.F.EXT		11	1	9	I	EC.F.PEN	
	17	53	21	III	EC.F.EXT		3	34	24	II	EC.F.PEN		11	25	59	II	OM.F.INT	
	17	59	5	III	EC.F.PEN		3	34	38	I	EC.F.PEN		11	30	32	II	OM.F.EXT	
	19	32	17	II	OM.F.INT		21	16	52	I	PA.D.EXT		11	54	59	III	OM.F.INT	
	19	36	49	II	OM.F.EXT		21	20	40	I	PA.D.INT		12	11	6	III	OM.F.EXT	
	20	3	32	I	EC.F.INT		22	34	27	I	OM.D.EXT							
	20	7	19	I	EC.F.EXT		22	38	17	I	OM.D.INT	12	4	42	19	I	PA.D.EXT	
	20	8	8	I	EC.F.PEN		23	26	45	I	PA.F.INT		4	46	6	I	PA.D.INT	
							23	30	33	I	PA.F.EXT		6	1	28	I	OM.D.EXT	
													6	5	17	I	OM.D.INT	
1	13	52	1	I	PA.D.EXT		7	0	44	25	I	OM.F.INT		6	52	16	I	PA.F.INT
	13	55	49	I	PA.D.INT		0	48	14	I	OM.F.EXT		6	56	4	I	PA.F.EXT	
	15	7	23	I	OM.D.EXT		14	25	44	III	OC.D.EXT		8	11	22	I	OM.F.INT	
	15	11	12	I	OM.D.INT		14	40	17	III	OC.D.INT		8	15	11	I	OM.F.EXT	
	16	1	50	I	PA.F.INT		16	33	16	III	OC.F.INT							
	16	5	38	I	PA.F.EXT		16	47	50	III	OC.F.EXT	13	0	55	2	II	OC.D.EXT	
	17	17	26	I	OM.F.INT		17	8	2	II	PA.D.EXT		0	59	34	II	OC.D.INT	
	17	21	14	I	OM.F.EXT		17	12	27	II	PA.D.INT		1	56	31	I	OC.D.EXT	
							18	31	26	I	OC.D.EXT		2	0	17	I	OC.D.INT	
2	9	3	33	II	OC.D.EXT		18	35	12	I	OC.D.INT		3	26	54	II	OC.F.INT	
	9	8	6	II	OC.D.INT		19	35	57	II	PA.F.INT		3	31	26	II	OC.F.EXT	
	11	7	1	I	OC.D.EXT		19	40	23	II	PA.F.EXT		3	39	59	II	EC.D.PEN	
	11	10	47	I	OC.D.INT		19	42	30	II	OM.D.EXT		3	41	52	II	EC.D.EXT	
	11	34	40	II	OC.F.INT		19	47	4	II	OM.D.INT		3	46	36	II	EC.D.INT	
	11	39	14	II	OC.F.EXT		19	47	26	III	EC.D.PEN		5	25	24	I	EC.F.INT	
	11	40	44	II	EC.D.PEN		19	53	11	III	EC.D.EXT		5	29	12	I	EC.F.EXT	
	11	42	37	II	EC.D.EXT		20	10	57	III	EC.D.INT		5	30	0	I	EC.F.PEN	
	11	47	20	II	EC.D.INT		21	37	9	III	EC.F.INT		6	6	48	II	EC.F.INT	
	14	7	52	II	EC.F.INT		21	54	57	III	EC.F.EXT		6	11	32	II	EC.F.EXT	
	14	12	35	II	EC.F.EXT		21	58	52	I	EC.F.INT		6	13	24	II	EC.F.PEN	
	14	14	28	II	EC.F.PEN		22	0	41	III	EC.F.PEN		23	11	1	I	PA.D.EXT	
	14	32	21	I	EC.F.INT		22	2	40	I	EC.F.EXT		23	14	48	I	PA.D.INT	
	14	36	9	I	EC.F.EXT		22	3	28	I	EC.F.PEN							
	14	36	57	I	EC.F.PEN		22	8	5	II	OM.F.INT	14	0	30	32	I	OM.D.EXT	
							22	12	38	II	OM.F.EXT		0	34	22	I	OM.D.INT	
3	8	20	15	I	PA.D.EXT								1	20	59	I	PA.F.INT	
	8	24	3	I	PA.D.INT		8	15	45	15	I	PA.D.EXT		1	24	47	I	PA.F.EXT
	9	36	26	I	OM.D.EXT		15	49	3	I	PA.D.INT		2	40	25	I	OM.F.INT	
	9	40	16	I	OM.D.INT		17	3	26	I	OM.D.EXT		2	44	14	I	OM.F.EXT	
	10	30	6	I	PA.F.INT		17	7	16	I	OM.D.INT		18	19	25	III	OC.D.EXT	
	10	33	54	I	PA.F.EXT		17	3	16	I	OM.D.INT		18	33	42	III	OC.D.INT	
	11	46	28	I	OM.F.INT		17	55	10	I	PA.F.INT		19	40	27	II	PA.D.EXT	
	11	50	17	I	OM.F.EXT		17	58	58	I	PA.F.EXT		19	44	52	II	PA.D.INT	
							19	13	23	I	OM.F.INT		20	25	1	I	OC.D.EXT	
							19	17	12	I	OM.F.EXT		20	28	47	I	OC.D.INT	
4	0	42	21	III	PA.D.EXT								20	29	13	III	OC.F.INT	
	0	57	3	III	PA.D.INT		9	11	36	56	II	OC.D.EXT		20	43	31	III	OC.F.EXT
	2	45	53	III	PA.F.INT		11	41	29	II	OC.D.INT		20	43	31	III	OC.F.EXT	
	3	0	46	III	PA.F.EXT		12	59	42	I	OC.D.EXT		22	8	41	II	PA.F.INT	
	3	52	42	II	PA.D.EXT		13	3	28	I	OC.D.INT		22	13	6	II	PA.F.EXT	
	3	57	7	II	PA.D.INT		14	8	35	II	OC.F.INT		22	18	35	II	OM.D.EXT	
	5	35	5	I	OC.D.EXT		14	13	8	II	OC.F.EXT		22	23	9	II	OM.D.INT	
	5	38	51	I	OC.D.INT		14	19	56	II	EC.D.PEN		23	49	26	III	EC.D.PEN	
	5	57	25	III	OM.D.EXT		14	21	48	II	EC.D.EXT		23	54	14	I	EC.F.INT	
	6	13	44	III	OM.D.INT		14	26	32	II	EC.D.INT		23	55	11	III	EC.D.EXT	
	6	20	25	II	PA.F.INT		16	27	42	I	EC.F.INT		23	58	2	I	EC.F.EXT	
	6	24	27	II	OM.D.EXT		16	31	30	I	EC.F.EXT		23	58	50	I	EC.F.PEN	
	6	24	51	II	PA.F.EXT		16	32	18	I	EC.F.PEN							
	6	29	0	II	OM.D.INT		16	46	51	II	EC.F.INT							
	7	52	44	III	OM.F.INT		16	51	34	II	EC.F.EXT	15	0	13	4	III	EC.D.INT	
	8	8	47	III	OM.F.EXT		16	53	27	II	EC.F.PEN		0	43	55	II	OM.F.INT	
	8	50	10	II	OM.F.INT								0	48	28	II	OM.F.EXT	
	8	54	42	II	OM.F.EXT								1	38	37	III	EC.F.INT	
	9	1	12	I	EC.F.INT		10	10	13	48	I	PA.D.EXT		1	56	30	III	EC.F.EXT
	9	4	59	I	EC.F.EXT		10	17	36	I	PA.D.INT		2	2	16	III	EC.F.PEN	
	9	5	48	I	EC.F.PEN		11	32	31	I	OM.D.EXT		17	39	41	I	PA.D.EXT	
							11	36	20	I	OM.D.INT		17	43	29	I	PA.D.INT	
							12	23	44	I	PA.F.INT		18	59	31	I	OM.D.EXT	
5	2	48	28	I	PA.D.EXT		12	27	32	I	PA.F.EXT		19	3	21	I	OM.D.INT	
	2	52	15	I	PA.D.INT		13	42	26	I	OM.F.INT		19	49	41	I	PA.F.INT	
	4	5	23	I	OM.D.EXT		13	46	15	I	OM.F.EXT		19	53	29	I	PA.F.EXT	
	4	9	13	I	OM.D.INT								21	9	23	I	OM.F.INT	
	4	58	19	I	PA.F.INT								21	13	12	I	OM.F.EXT	
	5	2	8	I	PA.F.EXT	11	4	34	8	III	PA.D.EXT							

2012 – CONFIGURATIONS DES SATELLITES GALILÉENS DE JUPITER

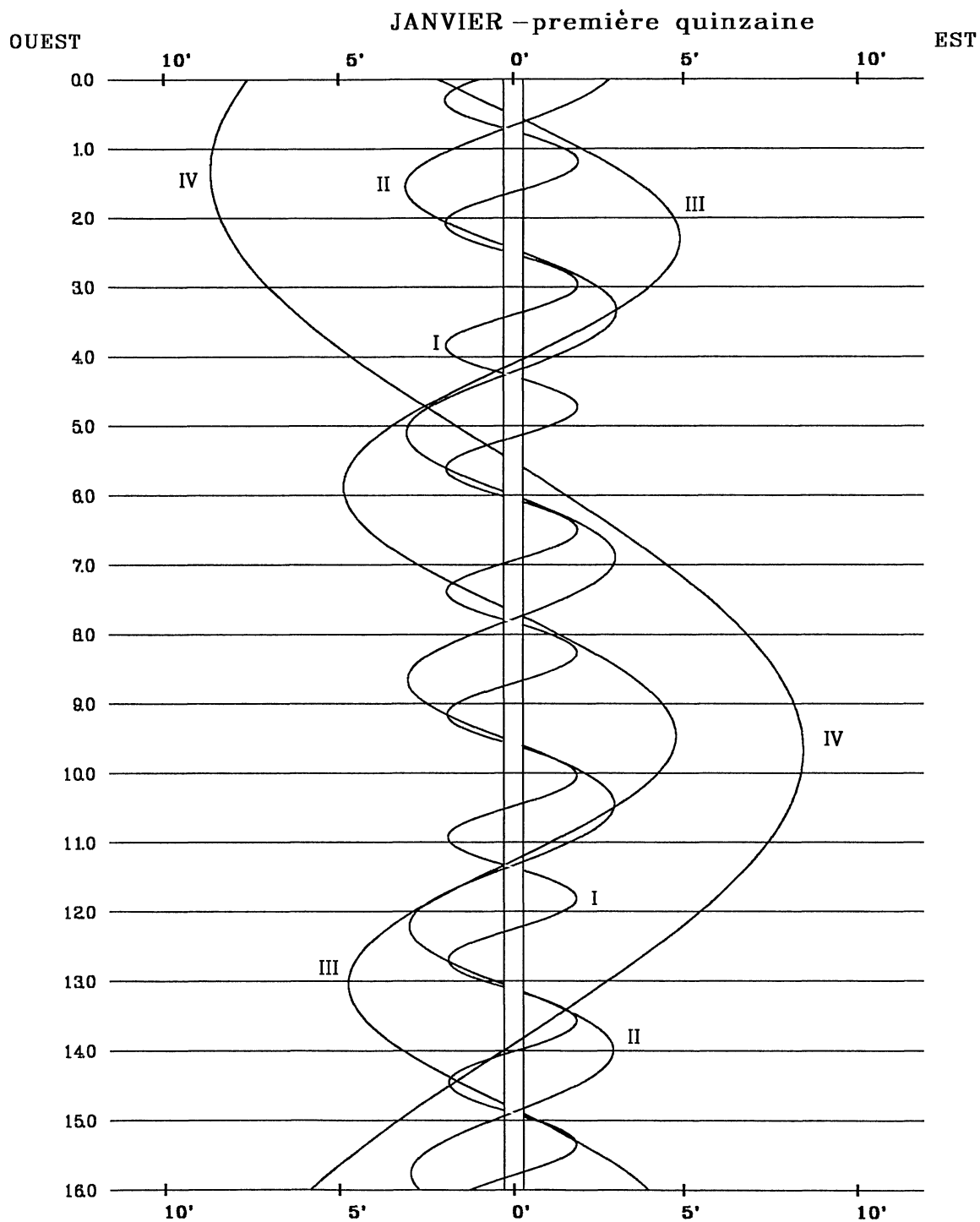

Dans le sens OUEST-EST, les satellites passent au-delà de Jupiter

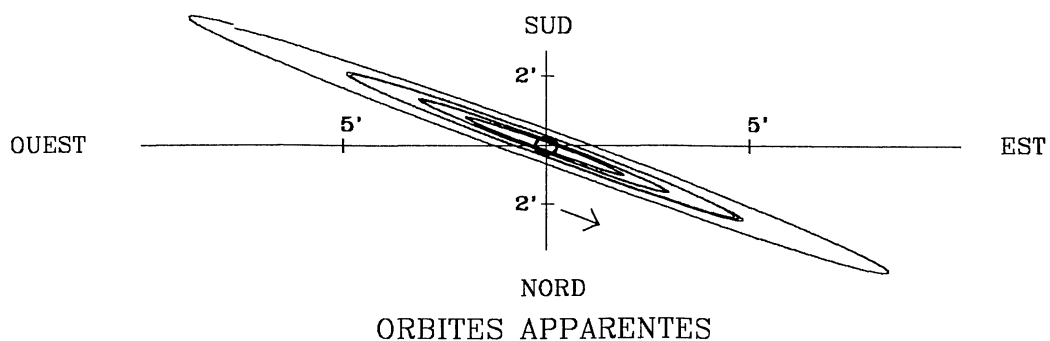

2012 - PHÉNOMÈNES DES SATELLITES GALILÉENS DE JUPITER
(Temps Terrestre)

FÉVRIER - PREMIÈRE QUINZAINE																			
jour	h	m	s	SAT.	TYPE	jour	h	m	s	SAT.	TYPE	jour	h	m	s	SAT.	TYPE		
1	13	13	48	I	OC.D.EXT	6	23	29	22	I	PA.D.EXT	11	16	49	3	II	EC.F.PEN		
	13	17	33	I	OC.D.INT		23	33	9	I	PA.D.INT		6	58	7	I	PA.D.EXT		
	14	11	1	II	PA.D.EXT		0	47	45	I	OM.D.EXT		7	1	54	I	PA.D.INT		
	14	15	24	II	PA.D.INT		0	51	34	I	OM.D.INT		8	14	48	I	OM.D.EXT		
	16	38	46	III	PA.D.EXT		1	39	41	I	PA.F.INT		8	18	38	I	OM.D.INT		
	16	39	48	II	PA.F.INT		1	43	29	I	PA.F.EXT		9	8	31	I	PA.F.INT		
	16	42	43	I	EC.F.INT		2	57	34	I	OM.F.INT		9	12	18	I	PA.F.EXT		
	16	44	13	II	PA.F.EXT		3	1	23	I	OM.F.EXT		10	24	39	I	OM.F.INT		
	16	46	31	I	EC.F.EXT		20	41	37	I	OC.D.EXT		10	28	28	I	OM.F.EXT		
	16	47	19	I	EC.F.PEN		20	45	23	I	OC.D.INT		12	4	9	56	I	OC.D.EXT	
	16	48	51	II	OM.D.EXT		22	14	2	II	OC.D.EXT			4	13	42	I	OC.D.INT	
	16	52	40	III	PA.D.INT		22	18	32	II	OC.D.INT			6	11	7	II	PA.D.EXT	
	16	53	27	II	OM.D.INT		7	0	9	16	I			EC.F.INT	6	15	31	II	PA.D.INT
	18	49	30	III	PA.F.INT			0	13	4	I			EC.F.EXT	7	35	49	I	EC.F.INT
	19	3	34	III	PA.F.EXT			0	13	52	I			EC.F.PEN	7	39	37	I	EC.F.EXT
	19	13	48	II	OM.F.INT			0	46	35	II			OC.F.INT	7	40	25	I	EC.F.PEN
	19	18	22	II	OM.F.EXT			0	51	6	II			OC.F.EXT	8	40	7	II	PA.F.INT
	22	8	40	III	OM.D.EXT			0	56	34	II			EC.D.PEN	8	43	6	II	OM.D.EXT
	22	25	16	III	OM.D.INT			0	58	27	II			EC.D.EXT	8	44	32	II	PA.F.EXT
	2	0	2	3	III			OM.F.INT	1	3	12		II	EC.D.INT	8	47	42	II	OM.D.INT
		0	18	21	III			OM.F.EXT	3	22	37		II	EC.F.INT	10	39	11	III	OC.D.EXT
		10	30	29	I			PA.D.EXT	3	27	22		II	EC.F.EXT	10	53	2	III	OC.D.INT
10		34	16	I	PA.D.INT	3	29	15	II	EC.F.PEN	11	7	58	II	OM.F.INT				
11		49	43	I	OM.D.EXT	17	58	57	I	PA.D.EXT	11	12	33	II	OM.F.EXT				
11		53	32	I	OM.D.INT	18	2	44	I	PA.D.INT	12	53	27	III	OC.F.INT				
12		40	45	I	PA.F.INT	19	16	49	I	OM.D.EXT	13	7	18	III	OC.F.EXT				
12		44	32	I	PA.F.EXT	19	20	38	I	OM.D.INT	15	57	26	III	EC.D.PEN				
13		59	32	I	OM.F.INT	20	9	18	I	PA.F.INT	16	3	16	III	EC.D.EXT				
14		3	21	I	OM.F.EXT	20	13	5	I	PA.F.EXT	16	21	32	III	EC.D.INT				
3		7	43	2	I	OC.D.EXT	21	26	39	I	OM.F.INT	17	44	40	III	EC.F.INT			
		7	46	47	I	OC.D.INT	21	30	28	I	OM.F.EXT	18	2	56	III	EC.F.EXT			
		8	53	2	II	OC.D.EXT	8	15	11	1	I	OC.D.EXT	18	8	47	III	EC.F.PEN		
		8	57	33	II	OC.D.INT		15	14	46	I	OC.D.INT	13	1	27	45	I	PA.D.EXT	
	11	11	35	I	EC.F.INT	15		14	46	I	OC.D.INT	1		31	32	I	PA.D.INT		
	11	15	23	I	EC.F.EXT	16		50	39	II	PA.D.EXT	2		43	46	I	OM.D.EXT		
	11	16	12	I	EC.F.PEN	16		55	3	II	PA.D.INT	2		43	46	I	OM.D.EXT		
	11	25	34	II	OC.F.INT	18		38	7	I	EC.F.INT	2		47	36	I	OM.D.INT		
	11	30	5	II	OC.F.EXT	18		41	55	I	EC.F.EXT	3		38	11	I	PA.F.INT		
	11	37	29	II	EC.D.PEN	18		42	43	I	EC.F.PEN	3		41	58	I	PA.F.EXT		
	11	39	22	II	EC.D.EXT	19		19	35	II	PA.F.INT	4		53	38	I	OM.F.INT		
	11	44	7	II	EC.D.INT	19		23	59	II	PA.F.EXT	4		57	27	I	OM.F.EXT		
	14	3	38	II	EC.F.INT	19		25	0	II	OM.D.EXT	22		39	28	I	OC.D.EXT		
	14	8	23	II	EC.F.EXT	19		29	36	II	OM.D.INT	22		43	13	I	OC.D.INT		
	14	10	16	II	EC.F.PEN	20		48	25	III	PA.D.EXT	14		0	58	14	II	OC.D.EXT	
	4	4	59	57	I	PA.D.EXT		21	2	15	III			PA.D.INT	1	2	45	II	OC.D.INT
		5	3	44	I	PA.D.INT		21	49	53	II			OM.F.INT	1	2	45	II	OC.D.INT
		6	18	46	I	OM.D.EXT		21	54	27	II			OM.F.EXT	2	4	39	I	EC.F.INT
6		22	36	I	OM.D.INT	22		59	57	III	PA.F.INT			2	8	28	I	EC.F.EXT	
7		10	14	I	PA.F.INT	23		13	57	III	PA.F.EXT			2	9	16	I	EC.F.PEN	
7		14	1	I	PA.F.EXT	9	2	10	52	III	OM.D.EXT			3	30	44	II	OC.F.INT	
8		28	35	I	OM.F.INT		2	27	31	III	OM.D.INT		3	35	15	II	OC.F.EXT		
8		32	24	I	OM.F.EXT		4	3	58	III	OM.F.INT		3	35	31	II	EC.D.PEN		
5	2	12	18	I	OC.D.EXT		4	20	19	III	OM.F.EXT		3	37	24	II	EC.D.EXT		
	2	16	3	I	OC.D.INT		4	20	19	III	OM.F.EXT	3	42	9	II	EC.D.INT			
	3	30	35	II	PA.D.EXT		12	28	27	I	PA.D.EXT	6	1	21	II	EC.F.INT			
	3	34	59	II	PA.D.INT		12	32	14	I	PA.D.INT	6	6	6	II	EC.F.EXT			
	5	40	25	I	EC.F.INT		13	45	45	I	OM.D.EXT	6	7	59	II	EC.F.PEN			
	5	44	14	I	EC.F.EXT	13	49	35	I	OM.D.INT	19	57	32	I	PA.D.EXT				
	5	45	2	I	EC.F.PEN	14	38	49	I	PA.F.INT	20	1	19	I	PA.D.INT				
	5	59	28	II	PA.F.INT	14	42	37	I	PA.F.EXT	21	12	49	I	OM.D.EXT				
	6	3	52	II	PA.F.EXT	15	55	36	I	OM.F.INT	21	16	39	I	OM.D.INT				
	6	6	55	II	OM.D.EXT	15	59	25	I	OM.F.EXT	22	7	59	I	PA.F.INT				
	6	11	30	II	OM.D.INT	10	9	40	28	I	OC.D.EXT	22	11	46	I	PA.F.EXT			
	6	27	53	III	OC.D.EXT		9	44	13	I	OC.D.INT	23	22	42	I	OM.F.INT			
	6	41	46	III	OC.D.INT		11	36	22	II	OC.D.EXT	23	26	31	I	OM.F.EXT			
	8	31	50	II	OM.F.INT		11	40	53	II	OC.D.INT	15	17	9	3	I	OC.D.EXT		
	8	36	24	II	OM.F.EXT		13	6	59	I	EC.F.INT		17	12	49	I	OC.D.INT		
	8	41	37	III	OC.F.INT		13	10	47	I	EC.F.EXT		19	31	59	II	PA.D.EXT		
	8	55	31	III	OC.F.EXT		13	11	35	I	EC.F.PEN		19	36	23	II	PA.D.INT		
	11	55	18	III	EC.D.PEN		14	8	54	II	OC.F.INT		20	33	30	I	EC.F.INT		
	12	1	7	III	EC.D.EXT		14	13	25	II	OC.F.EXT		20	37	18	I	EC.F.EXT		
	12	19	18	III	EC.D.INT		14	16	29	II	EC.D.PEN		20	38	6	I	EC.F.PEN		
	13	42	57	III	EC.F.INT	14	18	21	II	EC.D.EXT	22		1	0	II	PA.F.INT			
	14	1	8	III	EC.F.EXT	14	23	6	II	EC.D.INT	22		1	10	II	OM.D.EXT			
14	6	57	III	EC.F.PEN	16	42	25	II	EC.F.INT	22	5		25	II	PA.F.EXT				
					16	47	10	II	EC.F.EXT	22	5	46	II	OM.D.INT					

2012 - CONFIGURATIONS DES SATELLITES GALILÉENS DE JUPITER

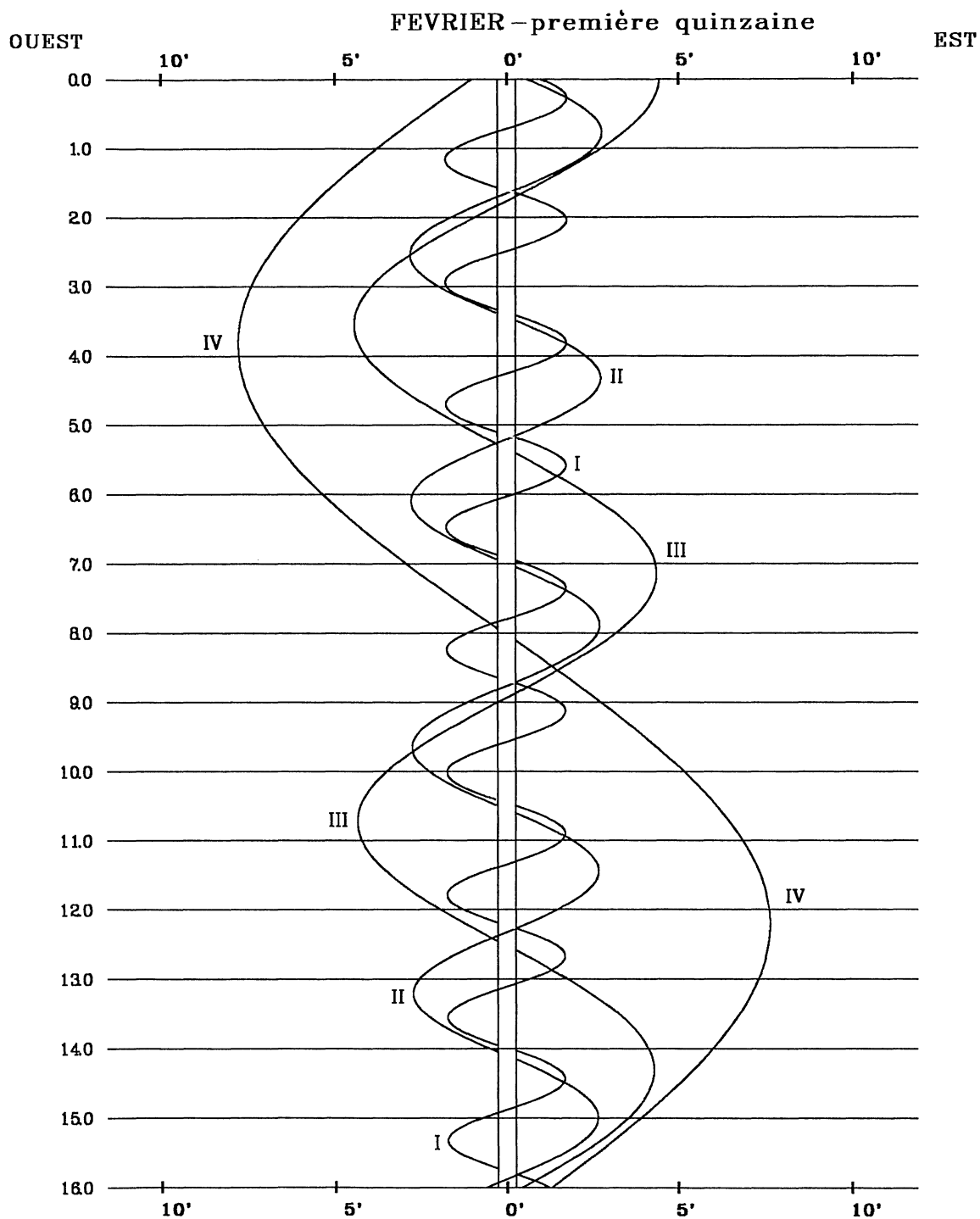

Dans le sens OUEST-EST, les satellites passent au-delà de Jupiter

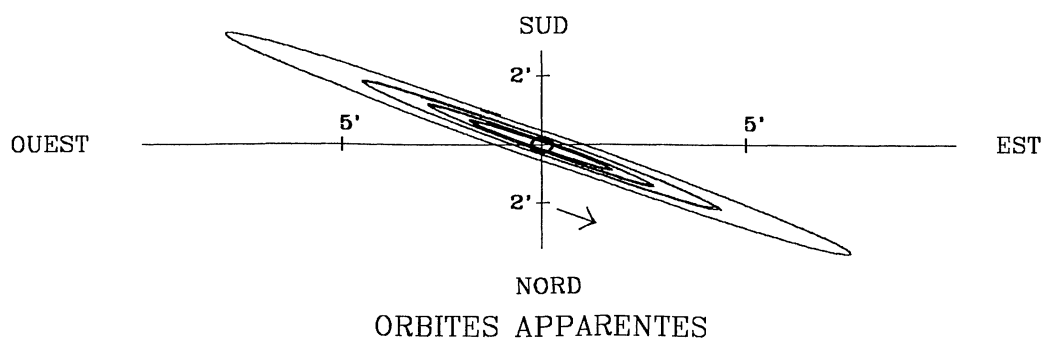

2012 - CONFIGURATIONS DES SATELLITES GALILÉENS DE JUPITER

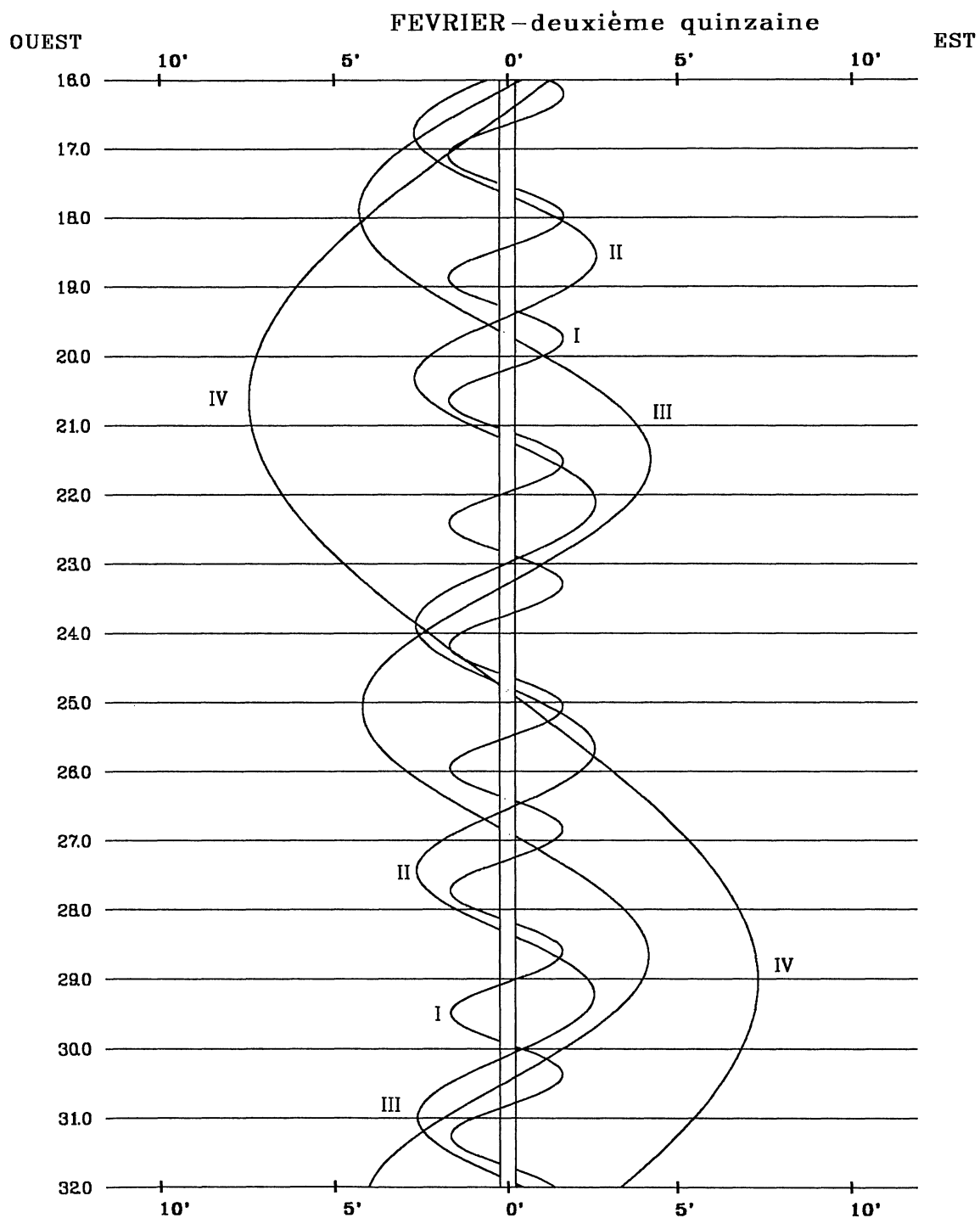

Dans le sens OUEST-EST, les satellites passent au-delà de Jupiter

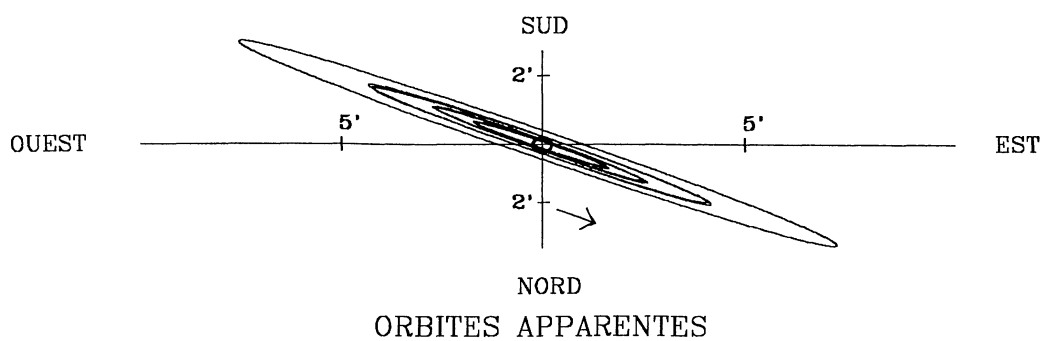

2012 - PHÉNOMÈNES DES SATELLITES GALILÉENS DE JUPITER
(Temps Terrestre)

MARS - PREMIÈRE QUINZAINE																	
jour	h	m	s	SAT.	TYPE	jour	h	m	s	SAT.	TYPE	jour	h	m	s	SAT.	TYPE
1	0	24	13	I	EC.F.INT		9	37	46	I	PA.F.INT	12	11	22	I	OC.D.INT	
	0	28	1	I	EC.F.EXT		9	41	33	I	PA.F.EXT	15	17	12	I	EC.F.INT	
	0	28	49	I	EC.F.PEN		10	41	32	I	OM.F.INT	15	21	0	I	EC.F.EXT	
	0	59	15	II	PA.D.EXT		10	45	21	I	OM.F.EXT	15	21	49	I	EC.F.PEN	
	1	3	40	II	PA.D.INT							17	8	6	II	PA.D.EXT	
	3	13	37	II	OM.D.EXT	6	4	37	19	I	OC.D.EXT	17	12	33	II	PA.D.INT	
	3	18	15	II	OM.D.INT		4	41	5	I	OC.D.INT	19	8	2	II	OM.D.EXT	
	3	28	20	II	PA.F.INT		7	50	43	I	EC.F.INT	19	12	41	II	OM.D.INT	
	3	32	46	II	PA.F.EXT		7	54	32	I	EC.F.EXT	19	37	8	II	PA.F.INT	
	5	38	29	II	OM.F.INT		7	55	20	I	EC.F.PEN	19	41	35	II	PA.F.EXT	
	5	43	6	II	OM.F.EXT		9	19	33	II	OC.D.EXT	21	32	58	II	OM.F.INT	
	9	37	24	III	PA.D.EXT		9	24	5	II	OC.D.INT	21	37	36	II	OM.F.EXT	
	9	51	17	III	PA.D.INT		13	56	45	II	EC.F.INT						
	11	49	28	III	PA.F.INT		14	1	31	II	EC.F.EXT	12	3	55	46	III	OC.D.EXT
	12	3	28	III	PA.F.EXT		14	3	23	II	EC.F.PEN	4	9	44	III	OC.D.INT	
	14	17	18	III	OM.D.EXT							6	9	10	III	OC.F.INT	
	14	34	5	III	OM.D.INT	7	1	57	17	I	PA.D.EXT	6	23	9	III	OC.F.EXT	
	16	9	39	III	OM.F.INT		2	1	4	I	PA.D.INT	8	5	9	III	EC.D.PEN	
	16	26	13	III	OM.F.EXT		3	0	28	I	OM.D.EXT	8	11	2	III	EC.D.EXT	
	18	26	48	I	PA.D.EXT		3	4	17	I	OM.D.INT	8	29	30	III	EC.D.INT	
	18	30	35	I	PA.D.INT		4	8	1	I	PA.F.INT	9	27	55	I	PA.D.EXT	
	19	33	33	I	OM.D.EXT		4	11	48	I	PA.F.EXT	9	31	42	I	PA.D.INT	
	19	37	23	I	OM.D.INT		5	10	33	I	OM.F.INT	9	51	16	III	EC.F.INT	
	20	37	28	I	PA.F.INT		5	14	22	I	OM.F.EXT	10	9	45	III	EC.F.EXT	
	20	41	15	I	PA.F.EXT		23	7	23	I	OC.D.EXT	10	15	37	III	EC.F.PEN	
	21	43	35	I	OM.F.INT		23	11	8	I	OC.D.INT	10	27	13	I	OM.D.EXT	
	21	47	24	I	OM.F.EXT							10	31	2	I	OM.D.INT	
2	15	37	19	I	OC.D.EXT	8	2	19	32	I	EC.F.INT	11	38	42	I	PA.F.INT	
	15	41	4	I	OC.D.INT		2	23	20	I	EC.F.EXT	11	42	29	I	PA.F.EXT	
	18	53	5	I	EC.F.INT		2	24	9	I	EC.F.PEN	12	37	21	I	OM.F.INT	
	18	56	53	I	EC.F.EXT		3	44	51	II	PA.D.EXT	12	41	10	I	OM.F.EXT	
	18	57	41	I	EC.F.PEN		3	49	17	II	PA.D.INT						
	19	55	37	II	OC.D.EXT		5	49	53	II	OM.D.EXT	13	6	37	45	I	OC.D.EXT
	20	0	8	II	OC.D.INT		5	54	31	II	OM.D.INT	6	41	31	I	OC.D.INT	
3	0	37	56	II	EC.F.INT		6	13	55	II	PA.F.INT	9	46	1	I	EC.F.INT	
	0	42	42	II	EC.F.EXT		6	18	22	II	PA.F.EXT	9	49	50	I	EC.F.EXT	
	0	44	34	II	EC.F.PEN		8	14	48	II	OM.F.INT	9	50	38	I	EC.F.PEN	
	12	56	57	I	PA.D.EXT		8	19	25	II	OM.F.EXT	12	8	50	II	OC.D.EXT	
	13	0	44	I	PA.D.INT		13	59	36	III	PA.D.EXT	12	13	22	II	OC.D.INT	
	14	2	33	I	OM.D.EXT		14	13	33	III	PA.D.INT	16	34	50	II	EC.F.INT	
	14	6	23	I	OM.D.INT		16	11	20	III	PA.F.INT	16	39	36	II	EC.F.EXT	
	15	7	38	I	PA.F.INT		16	25	23	III	PA.F.EXT	16	41	28	II	EC.F.PEN	
	15	11	26	I	PA.F.EXT		18	19	29	III	OM.D.EXT						
	16	12	36	I	OM.F.INT		18	36	18	III	OM.D.INT	14	3	58	15	I	PA.D.EXT
	16	16	25	I	OM.F.EXT		20	11	43	III	OM.F.INT	4	2	2	I	PA.D.INT	
4	10	7	18	I	OC.D.EXT		20	27	25	I	PA.D.EXT	4	56	11	I	OM.D.EXT	
	10	11	3	I	OC.D.INT		20	28	20	III	OM.F.EXT	5	0	1	I	OM.D.INT	
	13	21	53	I	EC.F.INT		20	31	12	I	PA.D.INT	6	9	3	I	PA.F.INT	
	13	25	42	I	EC.F.EXT		21	29	21	I	OM.D.EXT	6	12	50	I	PA.F.EXT	
	13	26	30	I	EC.F.PEN		21	33	10	I	OM.D.INT	7	6	21	I	OM.F.INT	
	14	21	55	II	PA.D.EXT		22	38	10	I	PA.F.INT	7	10	10	I	OM.F.EXT	
	14	26	20	II	PA.D.INT		22	41	57	I	PA.F.EXT						
	16	31	45	II	OM.D.EXT		23	39	27	I	OM.F.INT	15	1	7	56	I	OC.D.EXT
	16	36	23	II	OM.D.INT		23	43	16	I	OM.F.EXT	1	11	41	I	OC.D.INT	
	16	50	59	II	PA.F.INT	9	17	37	30	I	OC.D.EXT	4	14	49	I	EC.F.INT	
	16	55	26	II	PA.F.EXT		17	41	16	I	OC.D.INT	4	18	38	I	EC.F.EXT	
	18	56	38	II	OM.F.INT		20	48	24	I	EC.F.INT	4	19	26	I	EC.F.PEN	
	19	1	15	II	OM.F.EXT		20	52	12	I	EC.F.EXT	6	31	39	II	PA.D.EXT	
	23	33	10	III	OC.D.EXT		20	53	0	I	EC.F.PEN	6	36	6	II	PA.D.INT	
	23	47	4	III	OC.D.INT		22	44	26	II	OC.D.EXT	8	26	15	II	OM.D.EXT	
5	1	47	10	III	OC.F.INT		22	48	58	II	OC.D.INT	8	30	53	II	OM.D.INT	
	2	1	4	III	OC.F.EXT							9	0	38	II	PA.F.INT	
	4	3	47	III	EC.D.PEN	10	3	16	8	II	EC.F.INT	9	5	6	II	PA.F.EXT	
	4	9	38	III	EC.D.EXT		3	20	53	II	EC.F.EXT	10	51	13	II	OM.F.INT	
	4	28	4	III	EC.D.INT		3	22	46	II	EC.F.PEN	10	55	51	II	OM.F.EXT	
	5	50	8	III	EC.F.INT		14	57	42	I	PA.D.EXT	18	24	44	III	PA.D.EXT	
	6	8	34	III	EC.F.EXT		15	1	29	I	PA.D.INT	18	38	47	III	PA.D.INT	
	6	14	26	III	EC.F.PEN		15	58	19	I	OM.D.EXT	20	35	58	III	PA.F.INT	
	7	27	4	I	PA.D.EXT		16	2	8	I	OM.D.INT	20	50	6	III	PA.F.EXT	
	7	30	50	I	PA.D.INT		17	8	27	I	PA.F.INT	22	22	16	III	OM.D.EXT	
	8	31	28	I	OM.D.EXT		17	12	14	I	PA.F.EXT	22	28	30	I	PA.D.EXT	
	8	35	17	I	OM.D.INT		18	8	26	I	OM.F.INT	22	32	17	I	PA.D.INT	
							18	12	15	I	OM.F.EXT	22	39	6	III	OM.D.INT	
												23	25	3	I	OM.D.EXT	
												23	28	52	I	OM.D.INT	
							11	12	7	36	I	OC.D.EXT					

2012 - CONFIGURATIONS DES SATELLITES GALILÉENS DE JUPITER

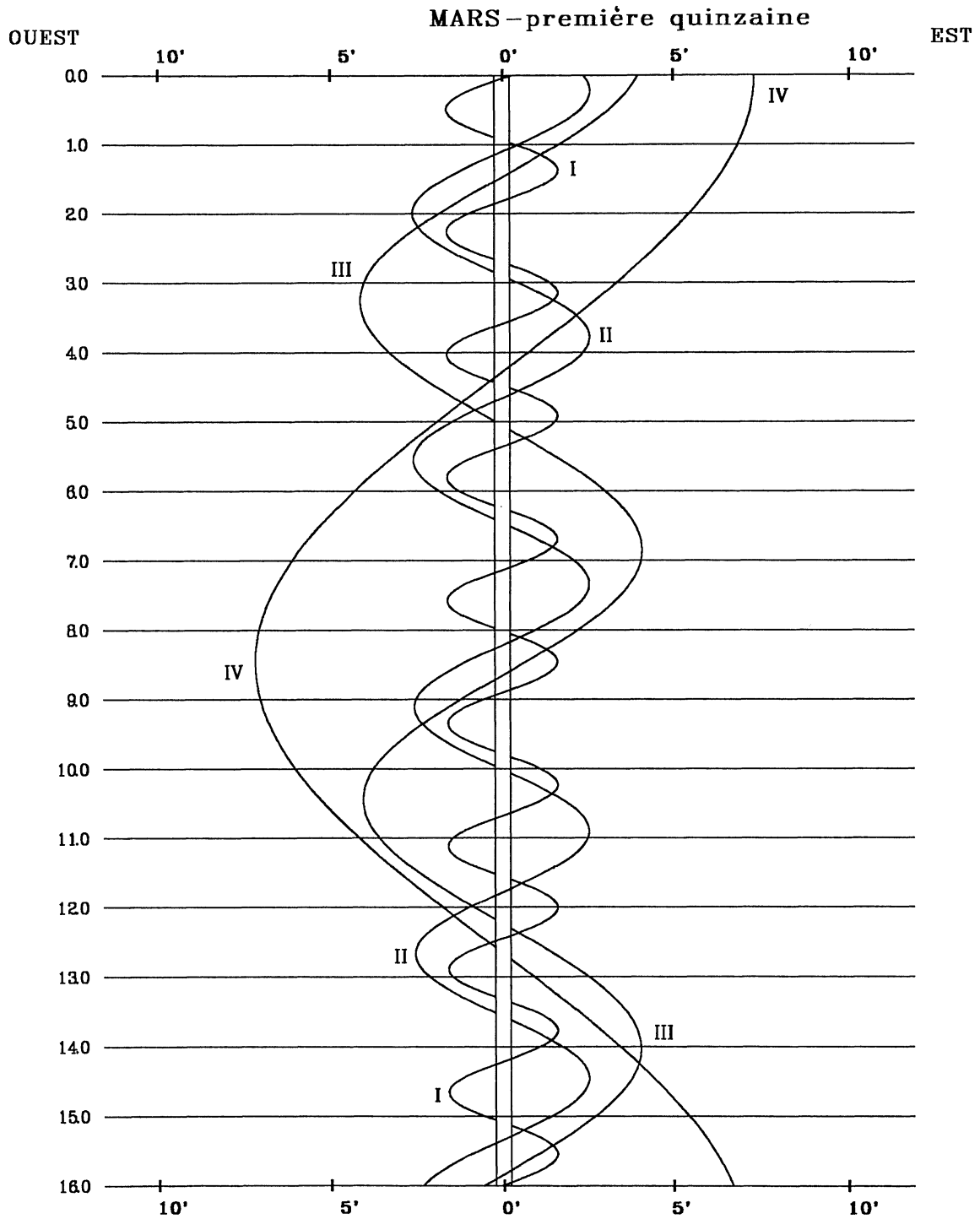

Dans le sens OUEST-EST, les satellites passent au-delà de Jupiter

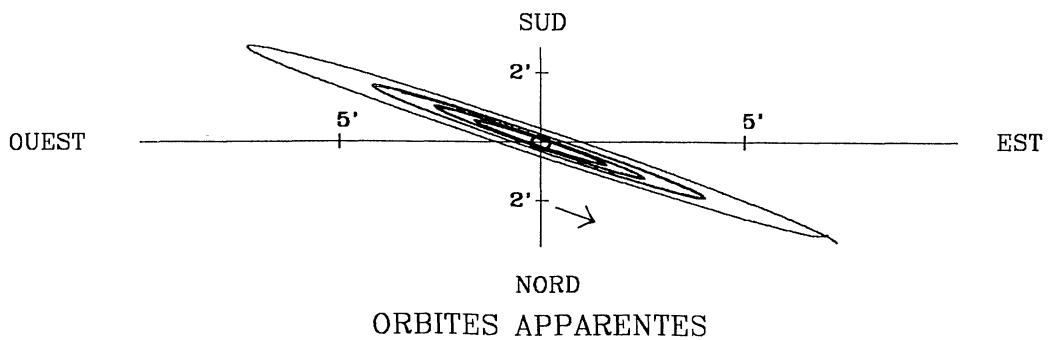

2012 - PHÉNOMÈNES DES SATELLITES GALILÉENS DE JUPITER
(Temps Terrestre)

MARS - DEUXIÈME QUINZAINE																			
jour	h	m	s	SAT.	TYPE	jour	h	m	s	SAT.	TYPE	jour	h	m	s	SAT.	TYPE		
16	0	14	26	III	OM.F.INT	22	9	5	52	I	OM.F.EXT	27	16	14	34	III	EC.D.EXT		
	0	31	5	III	OM.F.EXT		16	28	43	I	OM.F.INT		16	28	43	I	OM.F.INT		
	0	39	18	I	PA.F.INT		16	32	32	I	OM.F.EXT		16	32	32	I	OM.F.EXT		
	0	43	6	I	PA.F.EXT		3	12	41	I	OC.D.INT		16	33	9	III	EC.D.INT		
	1	35	14	I	OM.F.INT		6	10	4	I	EC.F.INT		17	54	23	III	EC.F.INT		
	1	39	3	I	OM.F.EXT		6	13	53	I	EC.F.EXT		18	12	57	III	EC.F.EXT		
	19	38	10	I	OC.D.EXT		6	14	41	I	EC.F.PEN		18	18	51	III	EC.F.PEN		
	19	41	56	I	OC.D.INT		9	19	26	II	PA.D.EXT		28	10	39	55	I	OC.D.EXT	
	22	43	40	I	EC.F.INT		9	23	54	II	PA.D.INT			10	43	41	I	OC.D.INT	
	22	47	29	I	EC.F.EXT		11	2	37	II	OM.D.EXT			10	43	41	I	OC.D.INT	
	22	48	17	I	EC.F.PEN		11	7	16	II	OM.D.INT			13	36	31	I	EC.F.INT	
	17	1	34	7	II		OC.D.EXT	11	48	19	II			PA.F.INT	13	40	20	I	EC.F.EXT
		1	38	39	II		OC.D.INT	11	52	48	II			PA.F.EXT	13	41	8	I	EC.F.PEN
5		54	5	II	EC.F.INT	13	27	39	II	OM.F.INT	17	49		38	II	OC.D.EXT			
5		58	51	II	EC.F.EXT	13	32	17	II	OM.F.EXT	17	54		11	II	OC.D.INT			
6		0	43	II	EC.F.PEN	22	50	53	III	PA.D.EXT	21	50		25	II	EC.F.INT			
16		58	52	I	PA.D.EXT	23	5	2	III	PA.D.INT	21	55		10	II	EC.F.EXT			
17		2	39	I	PA.D.INT	23	0	29	56	I	PA.D.EXT	21		57	3	II	EC.F.PEN		
17		54	0	I	OM.D.EXT		0	33	43	I	PA.D.INT	29		8	1	16	I	PA.D.EXT	
17		57	49	I	OM.D.INT		1	1	26	III	PA.F.INT			8	5	3	I	PA.D.INT	
19		9	41	I	PA.F.INT		1	15	39	III	PA.F.EXT		8	47	20	I	OM.D.EXT		
19		13	28	I	PA.F.EXT		1	20	39	I	OM.D.EXT		8	51	10	I	OM.D.INT		
20		4	12	I	OM.F.INT		1	24	28	I	OM.D.INT		10	12	9	I	PA.F.INT		
20		8	1	I	OM.F.EXT		2	24	2	III	OM.D.EXT		10	15	56	I	PA.F.EXT		
18	14	8	23	I	OC.D.EXT		2	40	48	I	PA.F.INT		10	57	39	I	OM.F.INT		
	14	12	9	I	OC.D.INT		2	40	53	III	OM.D.INT		11	1	28	I	OM.F.EXT		
	17	12	28	I	EC.F.INT		2	44	35	I	PA.F.EXT		30	5	10	16	I	OC.D.EXT	
	17	16	16	I	EC.F.EXT		3	30	55	I	OM.F.INT			5	14	2	I	OC.D.INT	
	17	17	5	I	EC.F.PEN		3	34	44	I	OM.F.EXT			8	5	17	I	EC.F.INT	
	19	55	24	II	PA.D.EXT		4	16	11	III	OM.F.INT			8	9	6	I	EC.F.EXT	
	19	59	52	II	PA.D.INT	4	32	52	III	OM.F.EXT	8			9	54	I	EC.F.PEN		
	21	44	24	II	OM.D.EXT	21	39	15	I	OC.D.EXT	12	8		9	II	PA.D.EXT			
	21	49	3	II	OM.D.INT	21	43	1	I	OC.D.INT	12	12		38	II	PA.D.INT			
	22	24	20	II	PA.F.INT	24	0	38	55	I	EC.F.INT	13		39	3	II	OM.D.EXT		
	22	28	49	II	PA.F.EXT		0	42	44	I	EC.F.EXT	13		43	43	II	OM.D.INT		
	19	0	9	23	II		OM.F.INT	0	43	32	I	EC.F.PEN		14	36	52	II	PA.F.INT	
		0	14	1	II		OM.F.EXT	4	24	32	II	OC.D.EXT		14	41	22	II	PA.F.EXT	
8		20	32	III	OC.D.EXT		4	29	5	II	OC.D.INT	16		4	9	II	OM.F.INT		
8		34	37	III	OC.D.INT		8	31	53	II	EC.F.INT	16		8	48	II	OM.F.EXT		
10		33	10	III	OC.F.INT		8	36	38	II	EC.F.EXT	31	2	31	40	I	PA.D.EXT		
10		47	15	III	OC.F.EXT		8	38	30	II	EC.F.PEN		2	35	27	I	PA.D.INT		
11		29	11	I	PA.D.EXT		19	0	23	I	PA.D.EXT		3	16	9	I	OM.D.EXT		
11		32	58	I	PA.D.INT		19	4	10	I	PA.D.INT		3	18	29	III	PA.D.EXT		
12		6	34	III	EC.D.PEN		19	49	34	I	OM.D.EXT		3	19	58	I	PA.D.INT		
12		12	27	III	EC.D.EXT		19	53	23	I	OM.D.INT		3	19	58	I	PA.D.INT		
12		22	52	I	OM.D.EXT		21	11	15	I	PA.F.INT		3	32	45	III	PA.D.INT		
12		26	41	I	OM.D.INT	21	15	2	I	PA.F.EXT	4		42	34	I	PA.F.INT			
12		30	59	III	EC.D.INT	21	59	51	I	OM.F.INT	4		46	21	I	PA.F.EXT			
13	40	1	I	PA.F.INT	22	3	40	I	OM.F.EXT	5	26		29	I	OM.F.INT				
13	43	48	I	PA.F.EXT	25	16	9	34	I	OC.D.EXT	5		28	14	III	PA.F.INT			
13	52	28	III	EC.F.INT		16	13	20	I	OC.D.INT	5		30	18	I	OM.F.EXT			
14	11	0	III	EC.F.EXT		16	13	20	I	OC.D.INT	5		42	33	III	PA.F.EXT			
14	16	54	III	EC.F.PEN		19	7	42	I	EC.F.INT	6	25	31	III	OM.D.EXT				
14	33	5	I	OM.F.INT		19	11	31	I	EC.F.EXT	6	42	21	III	OM.D.INT				
14	36	54	I	OM.F.EXT		19	12	19	I	EC.F.PEN	8	17	42	III	OM.F.INT				
20	8	38	39	I		OC.D.EXT	22	43	39	II	PA.D.EXT	8	34	24	III	OM.F.EXT			
	8	42	25	I		OC.D.INT	22	48	8	II	PA.D.INT	23	40	42	I	OC.D.EXT			
	11	41	17	I		EC.F.INT	26	0	20	47	II	OM.D.EXT	23	44	28	I	OC.D.INT		
	11	45	6	I		EC.F.EXT		0	25	26	II	OM.D.INT	31	2	34	7	I	EC.F.INT	
	11	45	54	I		EC.F.PEN		1	12	27	II	PA.F.INT		2	37	56	I	EC.F.EXT	
	14	58	55	II		OC.D.EXT		1	16	57	II	PA.F.EXT		2	38	45	I	EC.F.PEN	
	15	3	27	II		OC.D.INT		2	45	50	II	OM.F.INT		7	15	27	II	OC.D.EXT	
	19	12	44	II	EC.F.INT	2		50	29	II	OM.F.EXT	7		20	0	II	OC.D.INT		
	19	17	29	II	EC.F.EXT	12		47	50	III	OC.D.EXT	11		9	24	II	EC.F.INT		
	19	19	22	II	EC.F.PEN	13		2	2	III	OC.D.INT	11		14	9	II	EC.F.EXT		
	21	5	59	36	I	PA.D.EXT		13	30	46	I	PA.D.EXT		11	16	1	II	EC.F.PEN	
		6	3	23	I	PA.D.INT		13	34	33	I	PA.D.INT		21	2	11	I	PA.D.EXT	
		6	51	49	I	OM.D.EXT		14	18	25	I	OM.D.EXT		21	5	58	I	PA.D.INT	
6		55	38	I	OM.D.INT	14		22	14	I	OM.D.INT	21		45	2	I	OM.D.EXT		
8		10	27	I	PA.F.INT	14		59	31	III	OC.F.INT	21		48	52	I	OM.D.INT		
8		14	14	I	PA.F.EXT	15	13	43	III	OC.F.EXT	23	13		4	I	PA.F.INT			
9		2	3	I	OM.F.INT	15	41	39	I	PA.F.INT	23	16	51	I	PA.F.EXT				
						15	45	26	I	PA.F.EXT	23	55	23	I	OM.F.INT				
						16	8	40	III	EC.D.PEN	23	59	12	I	OM.F.EXT				

2012 – CONFIGURATIONS DES SATELLITES GALILÉENS DE JUPITER

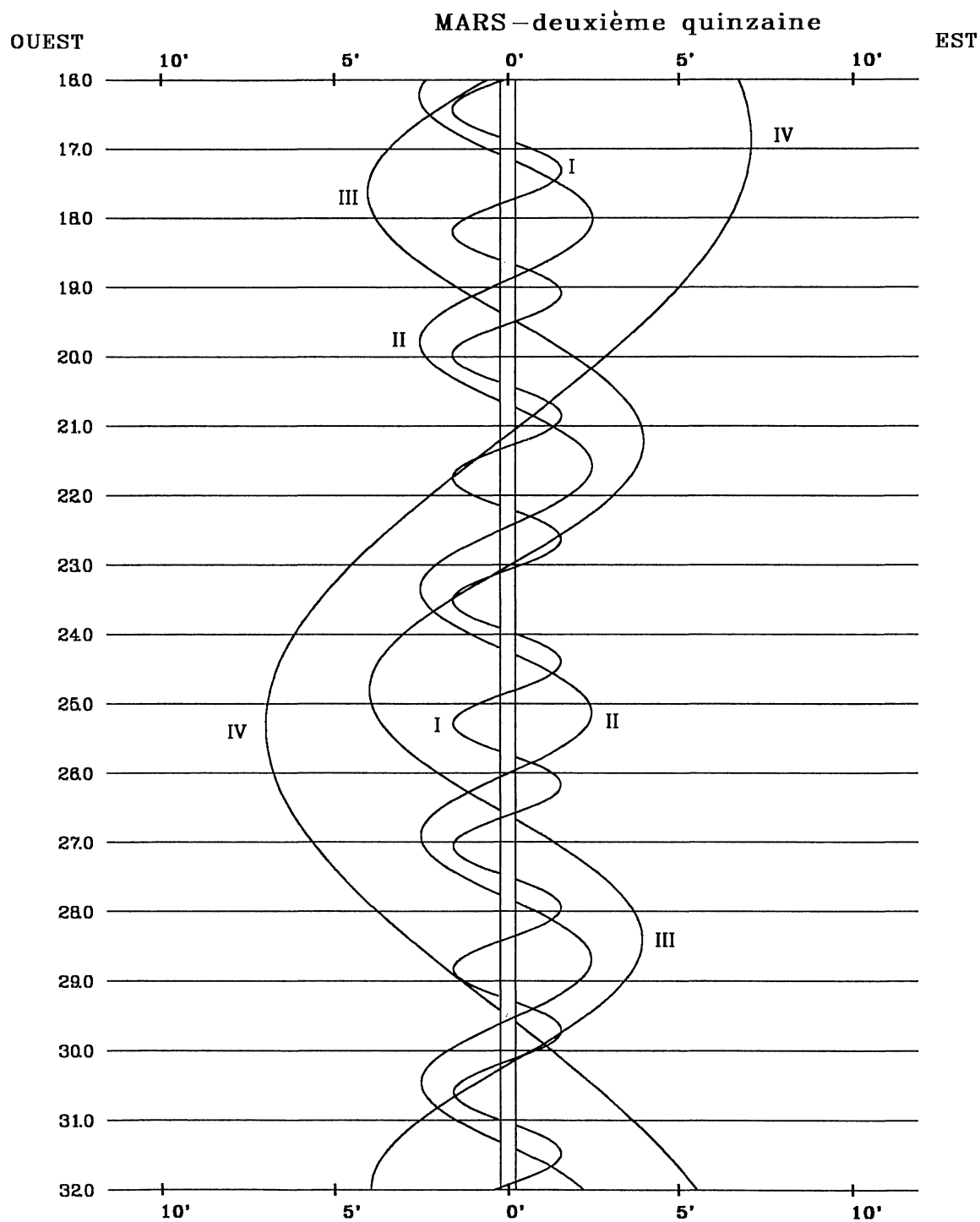

Dans le sens OUEST-EST, les satellites passent au-delà de Jupiter

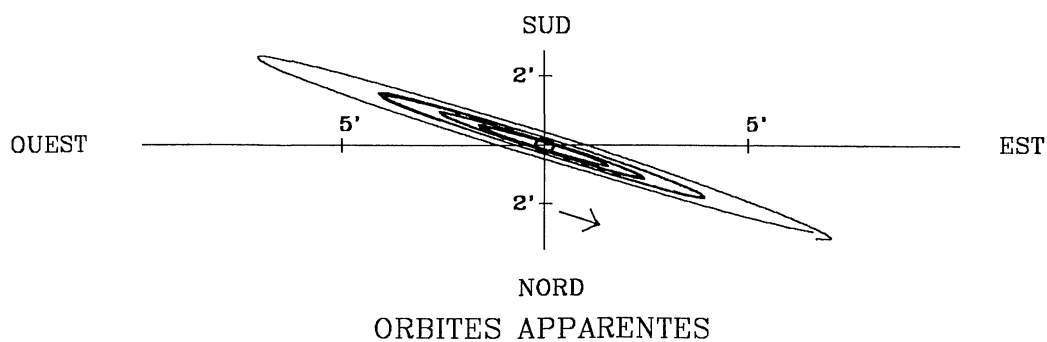

2012 - PHÉNOMÈNES DES SATELLITES GALILÉENS DE JUPITER
(Temps Terrestre)

AVRIL - PREMIÈRE QUINZAINE																				
jour	h	m	s	SAT.	TYPE	jour	h	m	s	SAT.	TYPE	jour	h	m	s	SAT.	TYPE			
1	18	11	5	I	OC.D.EXT	5	15	22	I	OM.D.INT	17	31	28	I	EC.F.PEN					
	18	14	51	I	OC.D.INT		6	44	32	I		PA.F.INT	23	32	18	II	OC.D.EXT			
	21	2	54	I	EC.F.INT		6	48	19	I		PA.F.EXT	23	36	52	II	OC.D.INT			
	21	6	42	I	EC.F.EXT		7	21	56	I		OM.F.INT								
	21	7	31	I	EC.F.PEN		7	25	45	I		OM.F.EXT	11	3	5	6	II	EC.F.INT		
2	1	32	47	II	PA.D.EXT	7	47	7	III	PA.D.EXT	11	3	9	51	II	EC.F.EXT				
	1	37	17	II	PA.D.INT	8	1	31	III	PA.D.INT	3	11	43	II	EC.F.PEN					
	2	57	15	II	OM.D.EXT	9	55	55	III	PA.F.INT	12	5	15	I	PA.D.EXT					
	3	1	55	II	OM.D.INT	10	10	22	III	PA.F.EXT	12	9	3	I	PA.D.INT					
	4	1	25	II	PA.F.INT	10	26	42	III	OM.D.EXT	12	38	4	I	OM.D.EXT					
	4	5	56	II	PA.F.EXT	10	43	33	III	OM.D.INT	12	41	53	I	OM.D.INT					
	5	22	22	II	OM.F.INT	12	18	55	III	OM.F.INT	14	16	9	I	PA.F.INT					
	5	27	2	II	OM.F.EXT	12	35	39	III	OM.F.EXT	14	19	56	I	PA.F.EXT					
	15	32	38	I	PA.D.EXT	7	1	42	25	I	OC.D.EXT	14	48	29	I	OM.F.INT				
	15	36	25	I	PA.D.INT		1	46	11	I	OC.D.INT	14	52	18	I	OM.F.EXT				
	16	13	52	I	OM.D.EXT		4	29	17	I	EC.F.INT	12	9	13	49	I	OC.D.EXT			
	16	17	41	I	OM.D.INT		4	33	6	I	EC.F.EXT		9	17	35	I	OC.D.INT			
	17	16	24	III	OC.D.EXT		4	33	55	I	EC.F.PEN		11	55	35	I	EC.F.INT			
	17	30	43	III	OC.D.INT		10	6	46	II	OC.D.EXT		11	59	24	I	EC.F.EXT			
	17	43	31	I	PA.F.INT		10	11	20	II	OC.D.INT		12	0	13	I	EC.F.PEN			
	17	47	19	I	PA.F.EXT		13	46	42	II	EC.F.INT		17	47	49	II	PA.D.EXT			
	18	24	13	I	OM.F.INT		13	51	28	II	EC.F.EXT		17	52	21	II	PA.D.INT			
	18	28	2	I	OM.F.EXT		13	53	20	II	EC.F.PEN		18	52	6	II	OM.D.EXT			
	19	27	1	III	OC.F.INT		23	4	11	I	PA.D.EXT		18	56	47	II	OM.D.INT			
	19	41	20	III	OC.F.EXT		23	7	58	I	PA.D.INT		20	16	7	II	PA.F.INT			
	20	10	22	III	EC.D.PEN		23	40	24	I	OM.D.EXT		20	20	40	II	PA.F.EXT			
	20	16	16	III	EC.D.EXT		23	44	13	I	OM.D.INT		21	17	18	II	OM.F.INT			
20	34	52	III	EC.D.INT	8		1	15	4	I	PA.F.INT	21	21	59	II	OM.F.EXT				
21	55	58	III	EC.F.INT			1	18	52	I	PA.F.EXT	13	6	35	45	I	PA.D.EXT			
22	14	34	III	EC.F.EXT			1	50	48	I	OM.F.INT		6	39	32	I	PA.D.INT			
22	20	28	III	EC.F.PEN			1	54	37	I	OM.F.EXT		7	6	49	I	OM.D.EXT			
3	12	41	30	I			OC.D.EXT	20	12	51	I		OC.D.EXT	7	10	38	I	OM.D.INT		
	12	45	17	I			OC.D.INT	20	16	38	I		OC.D.INT	8	46	38	I	PA.F.INT		
	15	31	42	I			EC.F.INT	22	58	3	I		EC.F.INT	8	50	25	I	PA.F.EXT		
	15	35	31	I			EC.F.EXT	23	1	52	I		EC.F.EXT	9	17	16	I	OM.F.INT		
	15	36	19	I		EC.F.PEN	23	2	40	I	EC.F.PEN		9	21	5	I	OM.F.EXT			
	20	40	48	II		OC.D.EXT	9	4	22	37	II		PA.D.EXT	12	16	54	III	PA.D.EXT		
	20	45	21	II		OC.D.INT		4	27	8	II		PA.D.INT	12	31	28	III	PA.D.INT		
	4	0	27	51		II		EC.F.INT	5	33	45		II	OM.D.EXT	14	24	40	III	PA.F.INT	
		0	32	37	II	EC.F.EXT		5	38	26	II		OM.D.INT	14	27	54	III	OM.D.EXT		
		0	34	29	II	EC.F.PEN		6	51	1	II	PA.F.INT	14	39	15	III	PA.F.EXT			
10		3	11	I	PA.D.EXT	6		55	33	II	PA.F.EXT	14	44	46	III	OM.D.INT				
10		6	58	I	PA.D.INT	7		58	55	II	OM.F.INT	16	20	11	III	OM.F.INT				
10		42	45	I	OM.D.EXT	8		3	36	II	OM.F.EXT	16	36	56	III	OM.F.EXT				
10		46	35	I	OM.D.INT	17		34	40	I	PA.D.EXT	14	3	44	21	I	OC.D.EXT			
12		14	4	I	PA.F.INT	17		38	27	I	PA.D.INT		3	48	8	I	OC.D.INT			
12		17	52	I	PA.F.EXT	18	9	12	I	OM.D.EXT	6		24	25	I	EC.F.INT				
12		53	8	I	OM.F.INT	18	13	1	I	OM.D.INT	6		28	14	I	EC.F.EXT				
12	56	57	I	OM.F.EXT	19	45	34	I	PA.F.INT	6	29		2	I	EC.F.PEN					
5	7	11	55	I	OC.D.EXT	19	49	21	I	PA.F.EXT	12		58	19	II	OC.D.EXT				
	7	15	42	I	OC.D.INT	20	19	37	I	OM.F.INT	13		2	53	II	OC.D.INT				
	10	0	27	I	EC.F.INT	20	23	25	I	OM.F.EXT	16		23	46	II	EC.F.INT				
	10	4	16	I	EC.F.EXT	21	46	48	III	OC.D.EXT	16		28	31	II	EC.F.EXT				
	10	5	5	I	EC.F.PEN	22	1	15	III	OC.D.INT	16		30	23	II	EC.F.PEN				
	14	57	39	II	PA.D.EXT	23	56	17	III	OC.F.INT	15	1	6	19	I	PA.D.EXT				
	15	2	10	II	PA.D.INT	10	0	10	44	III		OC.F.EXT	1	10	7	I	PA.D.INT			
	16	15	33	II	OM.D.EXT		0	12	35	III		EC.D.PEN	1	35	39	I	OM.D.EXT			
	16	20	13	II	OM.D.INT		0	18	29	III		EC.D.EXT	1	39	28	I	OM.D.INT			
	17	26	11	II	PA.F.INT		0	37	6	III		EC.D.INT	3	17	12	I	PA.F.INT			
17	30	42	II	PA.F.EXT	1		58	9	III	EC.F.INT		3	20	59	I	PA.F.EXT				
18	40	42	II	OM.F.INT	2		16	46	III	EC.F.EXT		3	46	6	I	OM.F.INT				
18	45	23	II	OM.F.EXT	2		22	40	III	EC.F.PEN		3	49	54	I	OM.F.EXT				
6	4	33	38	I	PA.D.EXT		14	43	21	I		OC.D.EXT	22	14	50	I	OC.D.EXT			
	4	37	25	I	PA.D.INT		14	47	7	I		OC.D.INT	22	18	37	I	OC.D.INT			
	5	11	33	I	OM.D.EXT		17	26	51	I	EC.F.INT									
						17	30	40	I	EC.F.EXT										

2012 – CONFIGURATIONS DES SATELLITES GALILÉENS DE JUPITER

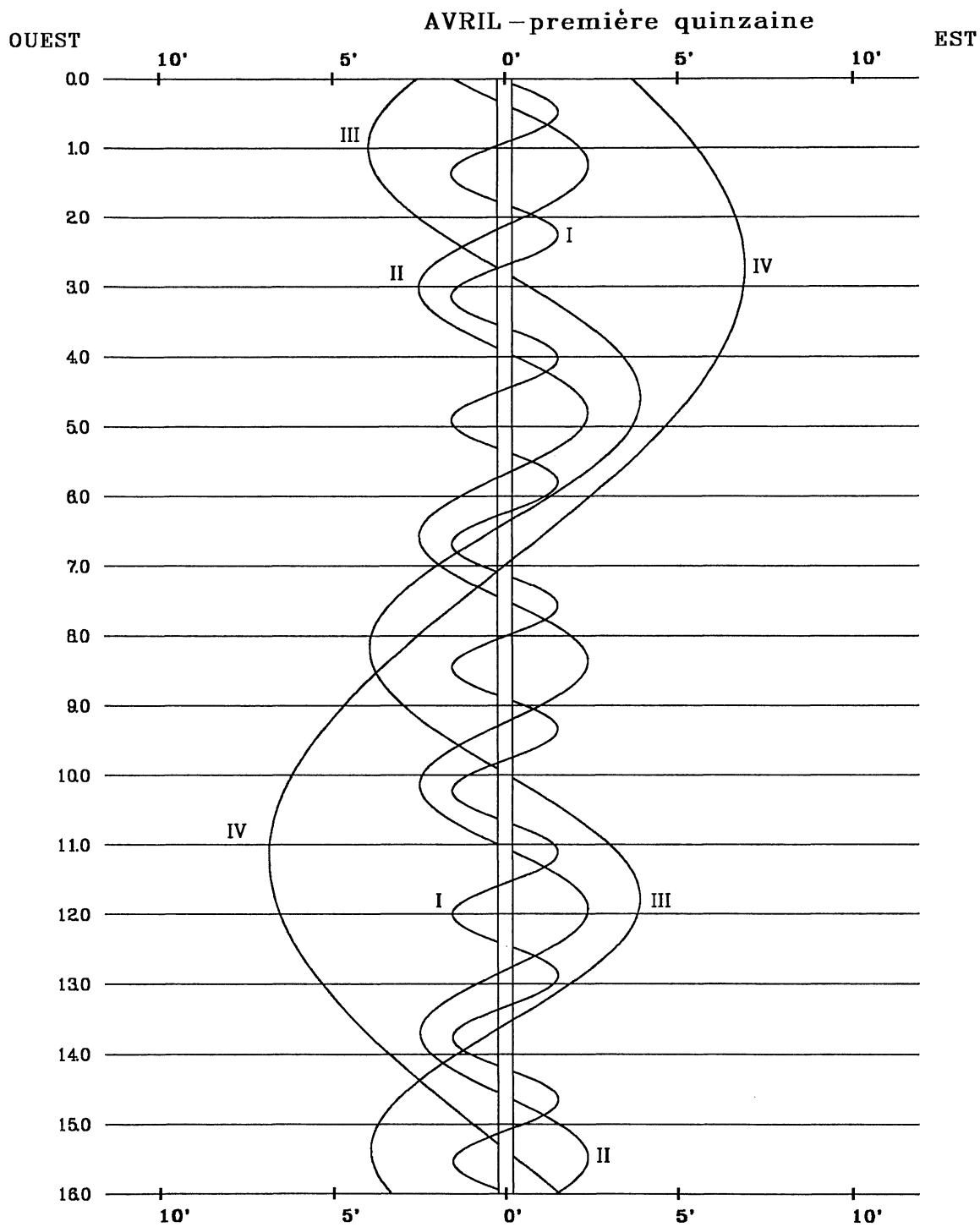

Dans le sens OUEST–EST, les satellites passent au-delà de Jupiter

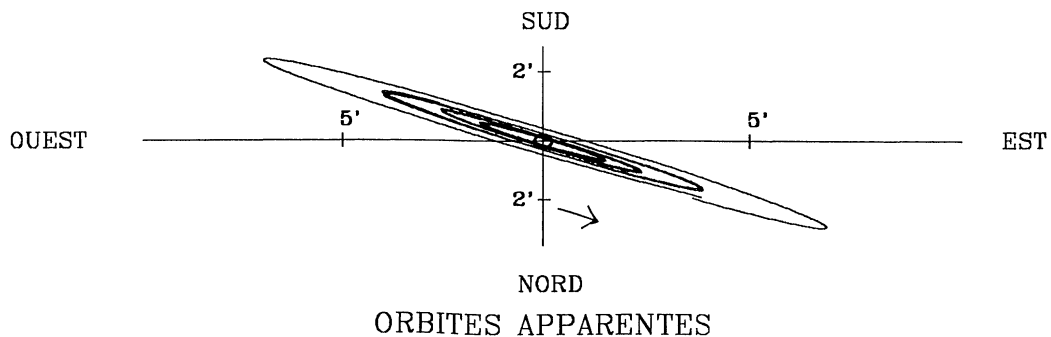

2012 - PHÉNOMÈNES DES SATELLITES GALILÉENS DE JUPITER
(Temps Terrestre)

MAI - PREMIÈRE QUINZAINE																																							
jour	h	m	s	SAT.	TYPE	jour	h	m	s	SAT.	TYPE	jour	h	m	s	SAT.	TYPE																						
1	1	52	8	I	PA.F.INT	7	0	18	15	II	EC.F.EXT	7	7	44	19	II	OM.F.INT																						
	1	55	55	I	PA.F.EXT		0	20	6	II	EC.F.PEN		7	45	2	II	PA.F.EXT																						
	2	4	59	I	OM.F.INT		7	13	4	I	PA.D.EXT		7	49	2	II	OM.F.EXT																						
	2	8	47	I	OM.F.EXT		7	16	51	I	PA.D.INT		14	44	41	I	PA.D.EXT																						
	11	19	51	III	OC.D.EXT		7	20	41	I	OM.D.EXT		14	46	45	I	OM.D.EXT																						
	11	34	45	III	OC.D.INT		7	24	29	I	OM.D.INT		14	48	28	I	PA.D.INT																						
	14	1	35	III	EC.F.INT		9	23	46	I	PA.F.INT		14	50	33	I	OM.D.INT																						
	14	20	10	III	EC.F.EXT		9	27	33	II	PA.F.EXT		16	55	19	I	PA.F.INT																						
	14	26	3	III	EC.F.PEN		9	31	9	I	OM.F.INT		16	57	13	I	OM.F.INT																						
	20	49	49	I	OC.D.EXT		9	34	58	I	OM.F.EXT		16	59	6	I	PA.F.EXT																						
	20	53	36	I	OC.D.INT		7	4	21	30	I		OC.D.EXT	12	6	24	5	III	PA.D.EXT																				
	23	12	0	I	EC.F.INT															4	25	18	I	OC.D.INT	6	33	48	III	OM.D.EXT										
	23	15	49	I	EC.F.EXT															6	38	12	I	EC.F.INT	6	39	15	III	PA.D.INT										
	23	16	38	I	EC.F.PEN															6	42	1	I	EC.F.EXT	6	39	15	III	PA.D.INT										
	2	8	7	18	II															OC.D.EXT	6	42	49	I	EC.F.PEN	6	50	35	III	OM.D.INT									
		8	11	54	II															OC.D.INT	15	47	13	II	PA.D.EXT	8	26	28	III	OM.F.INT									
		10	55	16	II															EC.F.INT	15	51	50	II	PA.D.INT	8	27	17	III	PA.F.INT									
11		0	1	II	EC.F.EXT	16						0								24	II	OM.D.EXT	8	42	27	III	PA.F.EXT												
11		1	52	II	EC.F.PEN	16						5								7	II	OM.D.INT	8	43	14	III	OM.F.EXT												
18		11	58	I	PA.D.EXT	18						14								26	II	PA.F.INT	11	53	15	I	OC.D.EXT												
18		15	45	I	PA.D.INT	18						19								3	II	PA.F.EXT	11	57	2	I	OC.D.INT												
18		23	16	I	OM.D.EXT	18						25								42	II	OM.F.INT	14	4	25	I	EC.F.INT												
18		27	5	I	OM.D.INT	18						30								25	II	OM.F.EXT	14	8	14	I	EC.F.EXT												
20		22	43	I	PA.F.INT	8						1								43	35	I	PA.D.EXT	13	0	24	29	II	OC.D.EXT										
20		26	30	I	PA.F.EXT																									1	47	22	I	PA.D.INT	0	29	5	II	OC.D.INT
20		33	45	I	OM.F.INT																									1	49	21	I	OM.D.EXT	2	51	19	II	OC.F.INT
20		37	33	I	OM.F.EXT																									1	53	10	I	OM.D.INT	2	55	55	II	OC.F.EXT
3	15	20	21	I	OC.D.EXT		3	54	16	I	PA.F.INT		2	56	12	II	EC.F.PEN																						
	15	24	8	I	OC.D.INT		3	58	4	I	PA.F.EXT		9	15	14	I	PA.D.EXT																						
	17	40	42	I	EC.F.INT		3	59	50	I	OM.F.INT		9	15	26	I	OM.D.EXT																						
	17	44	31	I	EC.F.EXT		4	3	38	I	OM.F.EXT		9	19	1	I	PA.D.INT																						
	17	45	20	I	EC.F.PEN		15	51	32	III	OC.D.EXT		9	19	15	I	OM.D.INT																						
	4	2	21	29	II		PA.D.EXT	16	6	35	III		OC.D.INT	9	19	15	I	OM.D.INT																					
2		26	6	II	PA.D.INT		18	2	32	III	EC.F.INT		11	25	50	I	PA.F.INT																						
2		42	11	II	OM.D.EXT		18	21	6	III	EC.F.EXT		11	25	53	I	OM.F.INT																						
2		46	54	II	OM.D.INT		18	26	59	III	EC.F.PEN		11	29	37	I	PA.F.EXT																						
4		48	54	II	PA.F.INT	22	52	6	I	OC.D.EXT	11	29	42	I	OM.F.EXT																								
4		53	31	II	PA.F.EXT	22	55	53	I	OC.D.INT	14	6	23	4	I	EC.D.PEN																							
5		7	30	II	OM.F.INT	9	1	6	57	I							EC.F.INT	6	23	47	I	OC.D.EXT																	
5		12	13	II	OM.F.EXT													1	10	46	I	EC.F.EXT	6	27	35	I	OC.D.INT												
12		42	30	I	PA.D.EXT													1	11	35	I	EC.F.PEN	8	34	47	I	OC.F.INT												
12		46	17	I	PA.D.INT													10	58	45	II	OC.D.EXT	8	38	34	I	OC.F.EXT												
12		51	57	I	OM.D.EXT													11	3	21	II	OC.D.INT	18	37	11	II	OM.D.EXT												
12		55	45	I	OM.D.INT													13	31	30	II	EC.F.INT	18	39	8	II	PA.D.EXT												
14		53	13	I	PA.F.INT													13	36	14	II	EC.F.EXT	18	41	54	II	OM.D.INT												
14		57	1	I	PA.F.EXT													13	38	5	II	EC.F.PEN	18	43	47	II	PA.D.INT												
15		2	26	I	OM.F.INT													20	14	11	I	PA.D.EXT	21	2	29	II	OM.F.INT												
15		6	14	I	OM.F.EXT													20	17	58	I	PA.D.INT	21	5	59	II	PA.F.INT												
5		1	52	21	III													PA.D.EXT	20	18	6	I	OM.D.EXT	21	7	13	II	OM.F.EXT											
	2	7	23	III	PA.D.INT													20	21	54	I	OM.D.INT	21	10	38	II	PA.F.EXT												
	2	32	57	III	OM.D.EXT													22	24	50	I	PA.F.INT	15	3	44	5	I	OM.D.EXT											
	2	49	45	III	OM.D.INT													22	28	33	I	OM.F.INT							3	45	44	I	PA.D.EXT						
	3	56	42	III	PA.F.INT													22	28	37	I	PA.F.EXT							3	47	53	I	OM.D.INT						
	4	11	43	III	PA.F.EXT													22	32	22	I	OM.F.EXT							3	49	31	I	PA.D.INT						
	4	25	36	III	OM.F.INT						10	17	22	38	I	OC.D.EXT		5	54	32	I	OM.F.INT																	
	4	42	20	III	OM.F.EXT	17	26	25	I	OC.D.INT							5	56	19	I	PA.F.INT																		
	9	50	58	I	OC.D.EXT	19	35	38	I	EC.F.INT							5	58	20	I	OM.F.EXT																		
	9	54	45	I	OC.D.INT	19	39	27	I	EC.F.EXT							6	0	6	I	PA.F.EXT																		
	12	9	29	I	EC.F.INT	19	40	16	I	EC.F.PEN							20	18	12	III	EC.D.PEN																		
	12	13	18	I	EC.F.EXT	11	5	13	21	II							PA.D.EXT	20	24	1	III	OC.D.EXT																	
	12	14	7	I	EC.F.PEN													5	17	59	II	PA.D.INT							20	39	15	III	OC.D.INT						
	21	33	9	II	OC.D.EXT													5	18	59	II	OM.D.EXT							22	27	20	III	OC.F.INT						
	21	37	45	II	OC.D.INT													5	23	43	II	OM.D.INT							22	42	34	III	OC.F.EXT						
	6	0	13	30	II													EC.F.INT	7	40	24	II							PA.F.INT										

2012 – CONFIGURATIONS DES SATELLITES GALILÉENS DE JUPITER

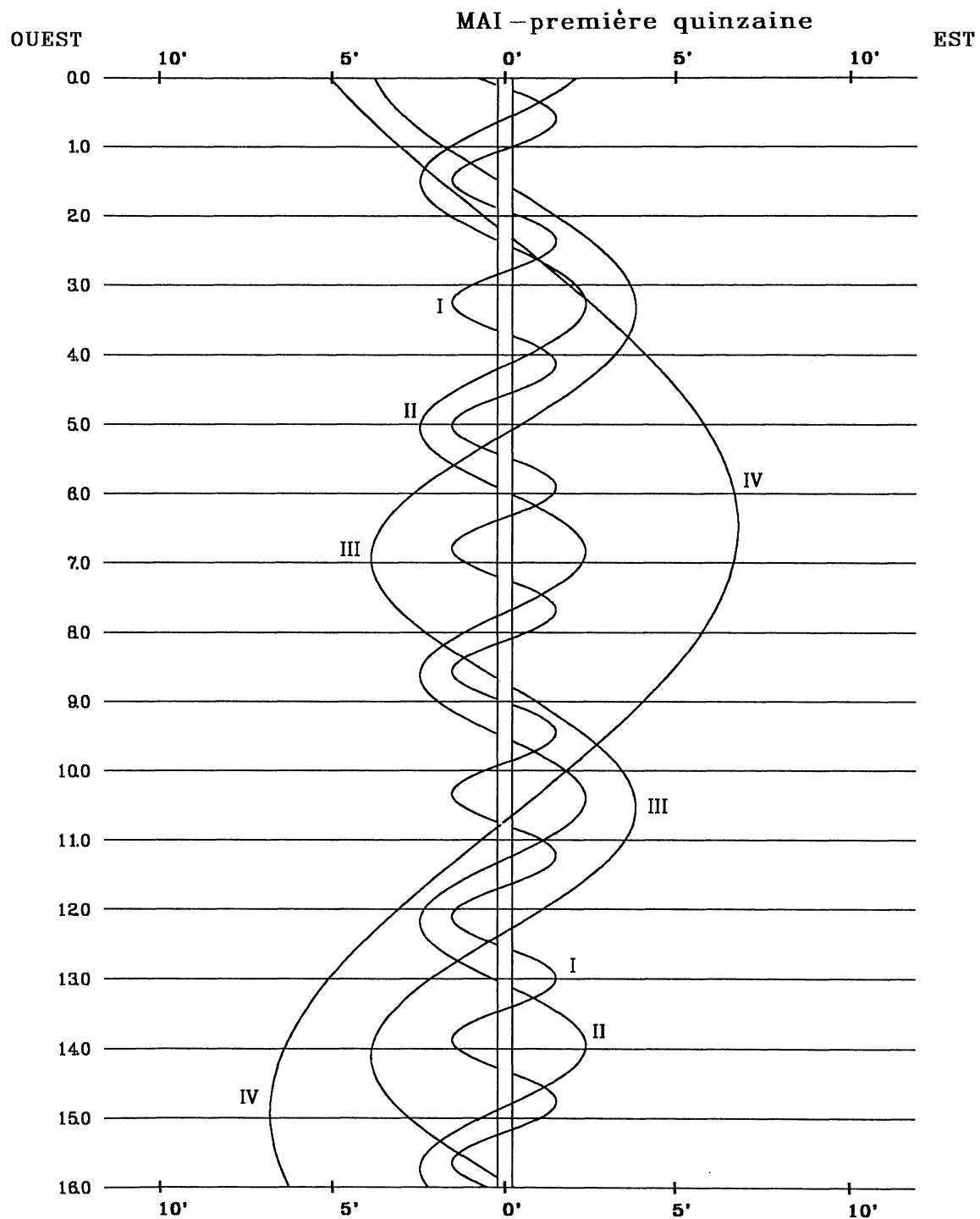

Dans le sens OUEST-EST, les satellites passent au-delà de Jupiter

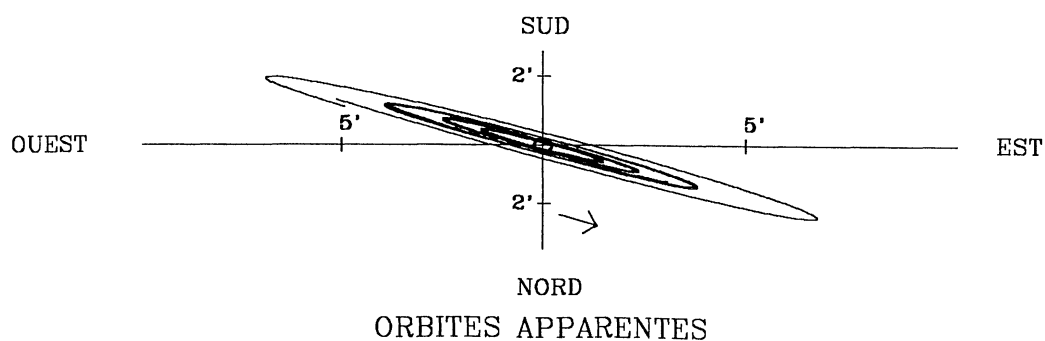

2012 - PHÉNOMÈNES DES SATELLITES GALILÉENS DE JUPITER
(Temps Terrestre)

MAI - DEUXIÈME QUINZAINE																			
jour	h	m	s	SAT.	TYPE	jour	h	m	s	SAT.	TYPE	jour	h	m	s	SAT.	TYPE		
16	0	51	47	I	EC.D.PEN	10	37	0	I	OC.F.INT	15	48	36	I	EC.D.INT				
	0	52	36	I	EC.D.EXT		10	40	48	I		OC.F.EXT	16	27	49	III	OM.F.INT		
	0	56	25	I	EC.D.INT		21	14	6	II		OM.D.EXT	16	44	30	III	OM.F.EXT		
	3	5	22	I	OC.F.INT		21	18	50	II		OM.D.INT	17	27	23	III	PA.F.INT		
	3	9	10	I	OC.F.EXT		21	31	13	II		PA.D.EXT	17	42	50	III	PA.F.EXT		
	13	44	11	II	EC.D.PEN		21	35	53	II		PA.D.INT	18	8	39	I	OC.F.INT		
	13	46	2	II	EC.D.EXT		23	39	23	II		OM.F.INT	18	12	27	I	OC.F.EXT		
	13	50	46	II	EC.D.INT		23	44	7	II		OM.F.EXT	27	5	37	58	II	EC.D.PEN	
	16	16	31	II	OC.F.INT		23	57	39	II		PA.F.INT		5	39	48	II	EC.D.EXT	
	16	21	7	II	OC.F.EXT		22	0	2	20		II		PA.F.EXT	5	44	32	II	EC.D.INT
	22	12	48	I	OM.D.EXT			5	38	43		I		OM.D.EXT	8	31	46	II	OC.F.INT
	22	16	17	I	PA.D.EXT			5	42	31		I		OM.D.INT	8	36	24	II	OC.F.EXT
	22	16	36	I	OM.D.INT			5	47	43		I		PA.D.EXT	13	4	39	I	OM.D.EXT
	22	20	4	I	PA.D.INT			5	51	31		I		PA.D.INT	13	8	27	I	OM.D.INT
17	0	23	14	I	OM.F.INT	7		49	7	I	OM.F.INT	13		19	7	I	PA.D.EXT		
	0	26	50	I	PA.F.INT	7		52	55	I	OM.F.EXT	13	22	54	I	PA.D.INT			
	0	27	2	I	OM.F.EXT	7	58	11	I	PA.F.INT	15	15	0	I	OM.F.INT				
	0	30	37	I	PA.F.EXT	8	1	58	I	PA.F.EXT	15	18	48	I	OM.F.EXT				
	19	20	27	I	EC.D.PEN	23	0	19	16	III	EC.D.PEN	15	29	28	I	PA.F.INT			
	19	21	15	I	EC.D.EXT		0	25	8	III	EC.D.EXT	15	33	15	I	PA.F.EXT			
	19	25	5	I	EC.D.INT		0	43	38	III	EC.D.INT	28	10	12	37	I	EC.D.PEN		
	21	35	53	I	OC.F.INT		2	46	35	I	EC.D.PEN		10	13	25	I	EC.D.EXT		
	21	39	41	I	OC.F.EXT		2	47	23	I	EC.D.EXT		10	17	15	I	EC.D.INT		
	18	7	55	50	II		OM.D.EXT	2	51	13	I		EC.D.INT	12	39	8	I	OC.F.INT	
8		0	34	II	OM.D.INT		2	58	7	III	OC.F.INT		12	42	56	I	OC.F.EXT		
8		5	23	II	PA.D.EXT		3	13	31	III	OC.F.EXT		23	51	3	II	OM.D.EXT		
8		10	3	II	PA.D.INT		5	7	35	I	OC.F.INT		23	55	48	II	OM.D.INT		
10		21	9	II	OM.F.INT		5	11	23	I	OC.F.EXT		29	0	23	13	II	PA.D.EXT	
10		25	53	II	OM.F.EXT	16	20	4	II	EC.D.PEN	0	27		54	II	PA.D.INT			
10		32	3	II	PA.F.INT	16	21	54	II	EC.D.EXT	2	16		18	II	OM.F.INT			
10		36	43	II	PA.F.EXT	16	26	38	II	EC.D.INT	2	16		18	II	OM.F.INT			
16		41	26	I	OM.D.EXT	19	6	46	II	OC.F.INT	2	21		3	II	OM.F.EXT			
16		45	14	I	OM.D.INT	19	11	23	II	OC.F.EXT	2	49		14	II	PA.F.INT			
16	46	46	I	PA.D.EXT	24	0	7	24	I	OM.D.EXT	2	53		56	II	PA.F.EXT			
16	50	33	I	PA.D.INT		0	11	12	I	OM.D.EXT	7	33		15	I	OM.D.EXT			
18	51	51	I	OM.F.INT		0	18	14	I	PA.D.EXT	7	37		3	I	OM.D.INT			
18	55	39	I	OM.F.EXT		0	18	14	I	PA.D.EXT	7	49		31	I	PA.D.EXT			
18	57	17	I	PA.F.INT		0	22	1	I	PA.D.INT	7	53	18	I	PA.D.INT				
19	1	4	I	PA.F.EXT		2	17	47	I	OM.F.INT	9	43	35	I	OM.F.INT				
19	10	34	14	III		OM.D.EXT	2	21	35	I	OM.F.EXT	9	47	23	I	OM.F.EXT			
	10	50	53	III		OM.D.INT	2	28	40	I	PA.F.INT	9	59	50	I	PA.F.INT			
	10	55	31	III		PA.D.EXT	2	32	27	I	PA.F.EXT	10	3	37	I	PA.F.EXT			
	11	10	50	III		PA.D.INT	21	15	13	I	EC.D.PEN	30	4	20	48	III	EC.D.PEN		
	12	27	16	III	OM.F.INT	21	16	2	I	EC.D.EXT	4		26	39	III	EC.D.EXT			
	12	44	0	III	OM.F.EXT	21	19	51	I	EC.D.INT	4		41	19	I	EC.D.PEN			
	12	57	34	III	PA.F.INT	23	38	4	I	OC.F.INT	4		42	8	I	EC.D.EXT			
	13	12	53	III	PA.F.EXT	23	41	52	I	OC.F.EXT	4		42	8	I	EC.D.EXT			
	13	49	12	I	EC.D.PEN	25	10	32	48	II	OM.D.EXT		4	45	5	III	EC.D.INT		
	13	50	0	I	EC.D.EXT		10	37	33	II	OM.D.INT		4	45	57	I	EC.D.INT		
13	53	50	I	EC.D.INT	10		37	33	II	OM.D.INT	7		9	41	I	OC.F.INT			
16	6	29	I	OC.F.INT	10		57	28	II	PA.D.EXT	7		13	29	I	OC.F.EXT			
16	10	17	I	OC.F.EXT	11		2	9	II	PA.D.INT	7		29	9	III	OC.F.INT			
20	3	2	13	II	EC.D.PEN		12	58	5	II	OM.F.INT	7	44	41	III	OC.F.EXT			
	3	4	3	II	EC.D.EXT		13	2	50	II	OM.F.EXT	18	55	45	II	EC.D.PEN			
	3	8	47	II	EC.D.INT		13	23	44	II	PA.F.INT	18	57	35	II	EC.D.EXT			
	5	41	44	II	OC.F.INT		13	28	25	II	PA.F.EXT	19	2	19	II	EC.D.INT			
	5	46	21	II	OC.F.EXT		18	36	1	I	OM.D.EXT	21	56	38	II	OC.F.INT			
	11	10	6	I	OM.D.EXT	18	39	49	I	OM.D.INT	22	1	16	II	OC.F.EXT				
	11	13	54	I	OM.D.INT	18	48	40	I	PA.D.EXT	31	2	1	54	I	OM.D.EXT			
	11	17	16	I	PA.D.EXT	18	52	27	I	PA.D.INT		2	5	42	I	OM.D.INT			
	11	21	3	I	PA.D.INT	20	46	23	I	OM.F.INT		2	19	58	I	PA.D.EXT			
	13	20	30	I	OM.F.INT	20	50	11	I	OM.F.EXT		2	23	45	I	PA.D.INT			
13	24	18	I	OM.F.EXT	20	59	4	I	PA.F.INT	4		12	13	I	OM.F.INT				
13	27	45	I	PA.F.INT	21	2	51	I	PA.F.EXT	4		16	1	I	OM.F.EXT				
13	31	33	I	PA.F.EXT	26	14	34	33	III	OM.D.EXT		4	30	15	I	PA.F.INT			
21	8	17	52	I		EC.D.PEN	14	51	10	III		OM.D.INT	4	34	2	I	PA.F.EXT		
	8	18	40	I		EC.D.EXT	15	26	29	III		PA.D.EXT	23	9	57	I	EC.D.PEN		
	8	22	30	I		EC.D.INT	15	41	56	III		PA.D.INT	23	10	45	I	EC.D.EXT		
	16	10	37	0		I	OC.F.INT	15	43	58	I	EC.D.PEN	23	14	35	I	EC.D.INT		
		10	40	48		I	OC.F.EXT	15	44	46	I	EC.D.EXT							

2012 - CONFIGURATIONS DES SATELLITES GALILÉENS DE JUPITER

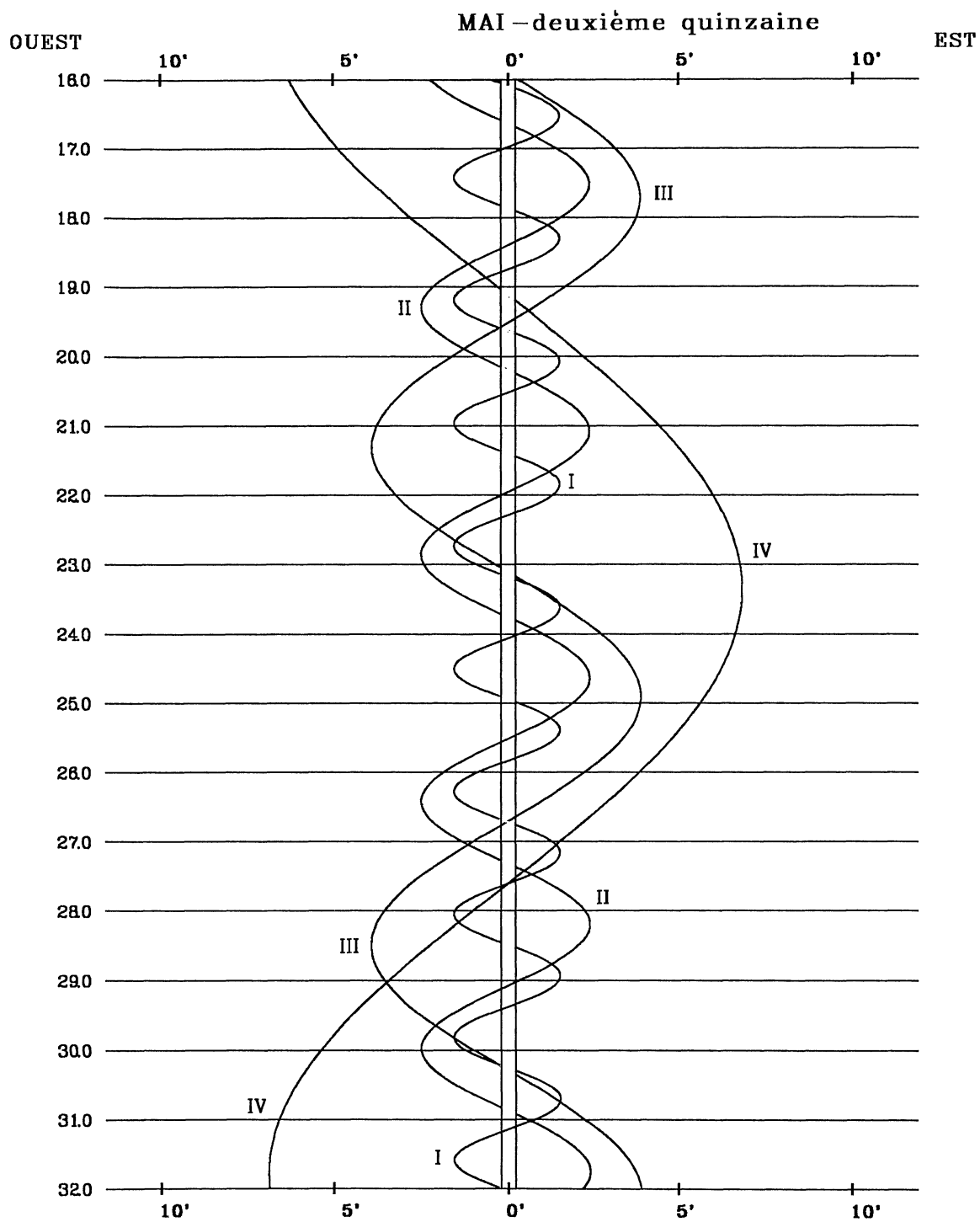

Dans le sens OUEST-EST, les satellites passent au-delà de Jupiter

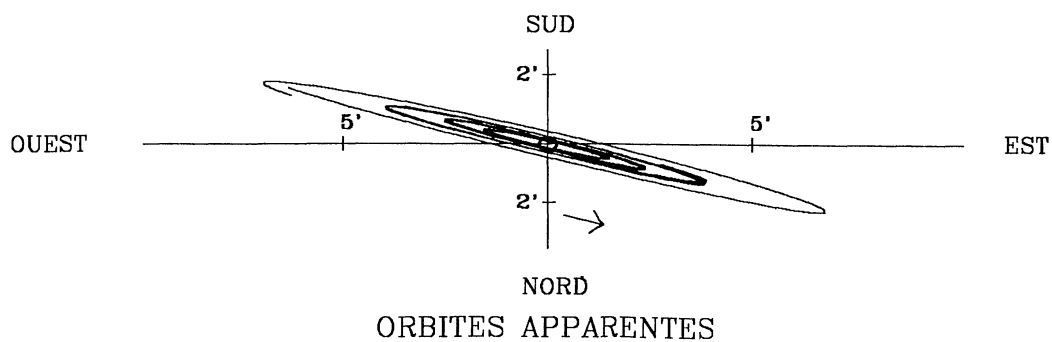

2012 - PHÉNOMÈNES DES SATELLITES GALILÉENS DE JUPITER
(Temps Terrestre)

JUIN - PREMIÈRE QUINZAINE																		
jour	h	m	s	SAT.	TYPE	jour	h	m	s	SAT.	TYPE	jour	h	m	s	SAT.	TYPE	
1	1	40	7	I	OC.F.INT	6	36	49	I	EC.D.EXT	19	32	7	I	PA.F.INT			
	1	43	56	I	OC.F.EXT	6	40	39	I	EC.D.INT	19	35	53	I	PA.F.EXT			
	13	9	50	II	OM.D.EXT	8	21	27	III	EC.D.PEN								
	13	14	34	II	OM.D.INT	8	27	17	III	EC.D.EXT	11	14	1	I	EC.D.PEN			
	13	49	27	II	PA.D.EXT	8	45	39	III	EC.D.INT	14	2	46	I	EC.D.EXT			
	13	54	9	II	PA.D.INT	9	11	36	I	OC.F.INT	14	6	35	I	EC.D.INT			
	15	35	4	II	OM.F.INT	9	15	25	I	OC.F.EXT	16	42	53	I	OC.F.INT			
	15	39	49	II	OM.F.EXT	11	58	50	III	OC.F.INT	16	46	41	I	OC.F.EXT			
	16	15	17	II	PA.F.INT	12	14	30	III	OC.F.EXT								
	16	19	59	II	PA.F.EXT	21	31	9	II	EC.D.PEN	12	5	5	II	OM.D.EXT			
	20	30	29	I	OM.D.EXT	21	32	59	II	EC.D.EXT	5	9	58	II	OM.D.INT			
	20	34	17	I	OM.D.INT	21	37	43	II	EC.D.INT	6	6	43	II	PA.D.EXT			
	20	50	20	I	PA.D.EXT						6	11	27	II	PA.D.INT			
	20	54	7	I	PA.D.INT	7	0	45	II	OC.F.INT	7	30	20	II	OM.F.INT			
	22	40	47	I	OM.F.INT	7	0	50	II	OC.F.EXT	7	35	6	II	OM.F.EXT			
	22	44	35	I	OM.F.EXT	3	56	19	I	OM.D.EXT	8	31	53	II	PA.F.INT			
	23	0	35	I	PA.F.INT	4	0	7	I	OM.D.INT	8	36	37	II	PA.F.EXT			
	23	4	22	I	PA.F.EXT	4	21	26	I	PA.D.EXT	11	22	1	I	OM.D.EXT			
						4	25	13	I	PA.D.INT	11	25	49	I	OM.D.INT			
2	17	38	40	I	EC.D.PEN	6	6	33	I	OM.F.INT	11	52	19	I	PA.D.EXT			
	17	39	29	I	EC.D.EXT	6	10	21	I	OM.F.EXT	11	56	6	I	PA.D.INT			
	17	43	18	I	EC.D.INT	6	31	34	I	PA.F.INT	13	32	11	I	OM.F.INT			
	18	34	55	III	OM.D.EXT	6	35	21	I	PA.F.EXT	13	35	59	I	OM.F.EXT			
	18	51	29	III	OM.D.INT						14	2	20	I	PA.F.INT			
	19	57	2	III	PA.D.EXT	8	1	4	37	I	EC.D.PEN	14	6	7	I	PA.F.EXT		
	20	10	40	I	OC.F.INT	1	5	25	I	EC.D.EXT								
	20	12	37	III	PA.D.INT	1	9	15	I	EC.D.INT	13	8	30	38	I	EC.D.PEN		
	20	14	28	I	OC.F.EXT	3	42	0	I	OC.F.INT	8	31	27	I	EC.D.EXT			
	20	28	26	III	OM.F.INT	3	45	48	I	OC.F.EXT	8	35	17	I	EC.D.INT			
	20	45	4	III	OM.F.EXT	15	46	58	II	OM.D.EXT	11	13	19	I	OC.F.INT			
	21	56	51	III	PA.F.INT	15	51	43	II	OM.D.INT	11	17	8	I	OC.F.EXT			
	22	12	26	III	PA.F.EXT	16	41	16	II	PA.D.EXT	12	21	53	III	EC.D.PEN			
						16	46	0	II	PA.D.INT	12	27	42	III	EC.D.EXT			
3	8	13	29	II	EC.D.PEN	18	12	8	II	OM.F.INT	12	45	59	III	EC.D.INT			
	8	15	19	II	EC.D.EXT	18	16	54	II	OM.F.EXT	14	9	8	III	EC.F.INT			
	8	20	3	II	EC.D.INT	19	6	40	II	PA.F.INT	14	27	25	III	EC.F.EXT			
	11	21	20	II	OC.F.INT	19	11	24	II	PA.F.EXT	14	28	32	III	OC.D.EXT			
	11	25	59	II	OC.F.EXT	22	24	53	I	OM.D.EXT	14	33	15	III	EC.F.PEN			
	14	59	6	I	OM.D.EXT	22	28	41	I	OM.D.INT	14	44	19	III	OC.D.INT			
	15	2	54	I	OM.D.INT	22	51	45	I	PA.D.EXT	16	27	38	III	OC.F.INT			
	15	20	43	I	PA.D.EXT	22	55	32	I	PA.D.INT	16	43	26	III	OC.F.EXT			
	15	24	30	I	PA.D.INT													
	17	9	23	I	OM.F.INT	9	0	35	6	I	OM.F.INT	14	0	6	22	II	EC.D.PEN	
	17	13	11	I	OM.F.EXT	9	0	38	53	I	OM.F.EXT	0	8	12	II	EC.D.EXT		
	17	30	56	I	PA.F.INT	1	1	51	I	PA.F.INT	0	12	55	II	EC.D.INT			
	17	34	43	I	PA.F.EXT	1	5	38	I	PA.F.EXT	3	34	39	II	OC.F.INT			
						19	33	20	I	EC.D.PEN	3	39	18	II	OC.F.EXT			
4	12	7	18	I	EC.D.PEN	19	34	8	I	EC.D.EXT	5	50	38	I	OM.D.EXT			
	12	8	7	I	EC.D.EXT	19	37	58	I	EC.D.INT	5	54	25	I	OM.D.INT			
	12	11	57	I	EC.D.INT	22	12	29	I	OC.F.INT	6	22	37	I	PA.D.EXT			
	14	41	6	I	OC.F.INT	22	16	18	I	OC.F.EXT	6	26	24	I	PA.D.INT			
	14	44	55	I	OC.F.EXT	22	35	54	III	OM.D.EXT	8	0	46	I	OM.F.INT			
						22	52	25	III	OM.D.INT	8	4	33	I	OM.F.EXT			
5	2	28	6	II	OM.D.EXT	10	0	27	34	III	PA.D.EXT	8	32	35	I	PA.F.INT		
	2	32	51	II	OM.D.INT	10	0	29	39	III	OM.F.INT	8	36	22	I	PA.F.EXT		
	3	15	5	II	PA.D.EXT	0	43	17	III	PA.D.INT	15	2	59	14	I	EC.D.PEN		
	3	19	48	II	PA.D.INT	0	46	15	III	OM.F.EXT	3	0	3	I	EC.D.EXT			
	4	53	17	II	OM.F.INT	2	26	20	III	PA.F.INT	3	3	52	I	EC.D.INT			
	4	58	3	II	OM.F.EXT	2	42	2	III	PA.F.EXT	5	43	39	I	OC.F.INT			
	5	40	41	II	PA.F.INT	10	48	46	II	EC.D.PEN	5	47	27	I	OC.F.EXT			
	5	45	24	II	PA.F.EXT	10	50	36	II	EC.D.EXT	18	24	7	II	OM.D.EXT			
	9	27	41	I	OM.D.EXT	10	55	19	II	EC.D.INT	18	28	52	II	OM.D.INT			
	9	31	29	I	OM.D.INT	14	10	21	II	OC.F.INT	19	32	45	II	PA.D.EXT			
	9	51	4	I	PA.D.EXT	14	14	59	II	OC.F.EXT	19	37	30	II	PA.D.INT			
	9	54	51	I	PA.D.INT	16	53	28	I	OC.D.EXT	20	49	13	II	OM.F.INT			
	11	37	56	I	OM.F.INT	16	57	16	I	OM.D.INT	20	53	59	II	OM.F.EXT			
	11	41	44	I	OM.F.EXT	17	22	3	I	PA.D.EXT	21	57	43	II	PA.F.INT			
	12	1	14	I	PA.F.INT	17	25	50	I	PA.D.INT	22	2	28	II	PA.F.EXT			
	12	5	1	I	PA.F.EXT	19	3	39	I	OM.F.INT								
6	6	36	0	I	EC.D.PEN	19	7	27	I	OM.F.EXT								

2012 – CONFIGURATIONS DES SATELLITES GALILÉENS DE JUPITER

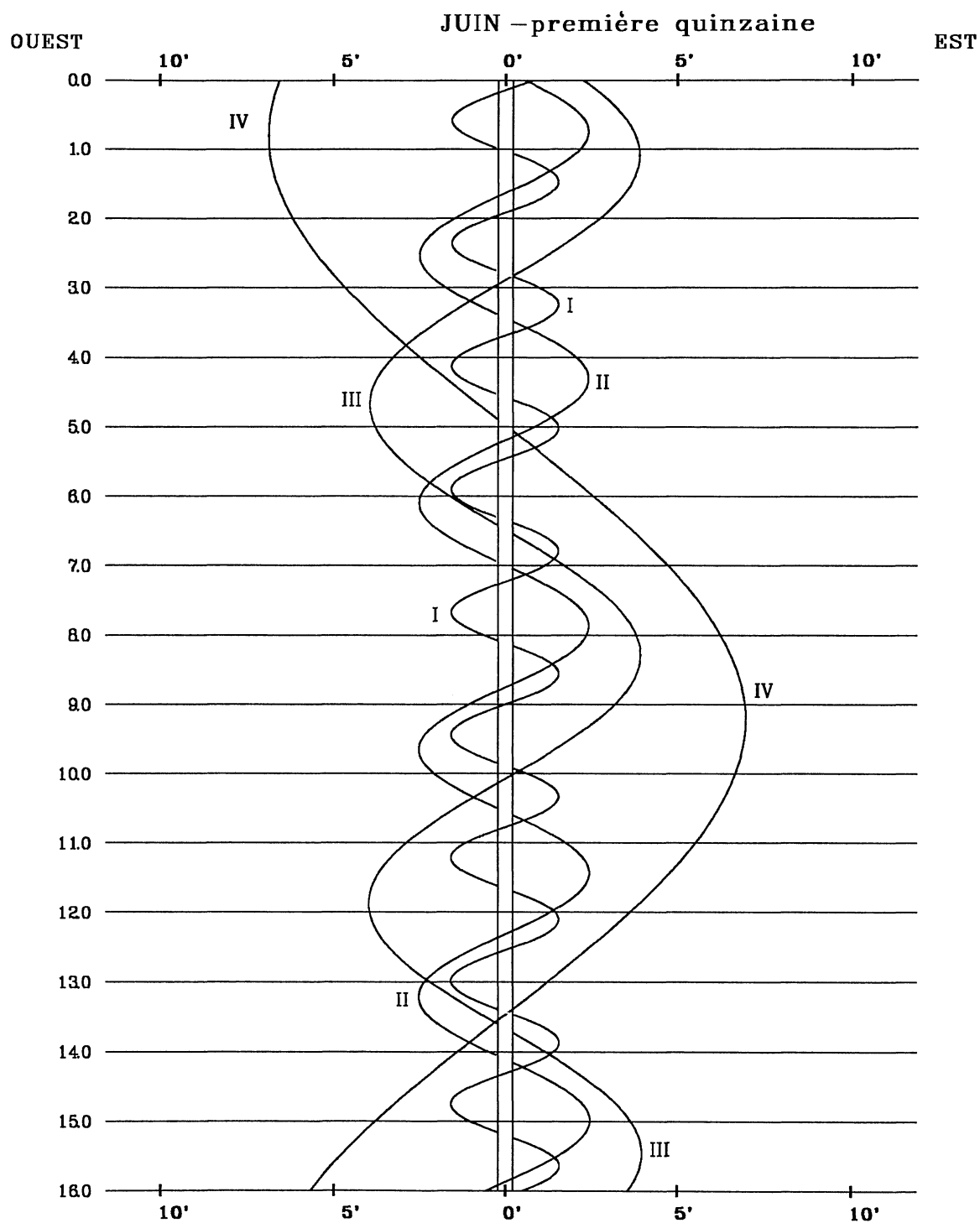

Dans le sens OUEST-EST, les satellites passent au-delà de Jupiter

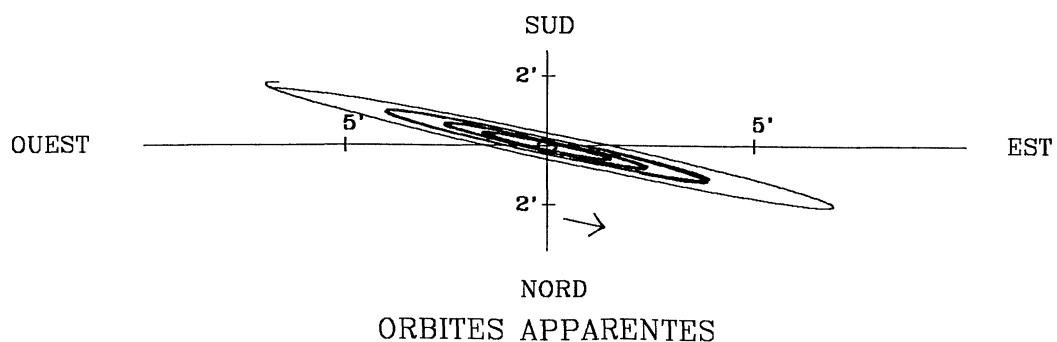

2012 - PHÉNOMÈNES DES SATELLITES GALILÉENS DE JUPITER
(Temps Terrestre)

JUIN - DEUXIÈME QUINZAINE																				
jour	h	m	s	SAT.	TYPE	jour	h	m	s	SAT.	TYPE	jour	h	m	s	SAT.	TYPE			
16	0	19	10	I	OM.D.EXT	21	2	41	21	II	EC.D.PEN	26	10	19	36	II	OM.D.EXT			
	0	22	58	I	OM.D.INT		21	11	15	III	OC.F.EXT		10	24	22	II	OM.D.INT			
	0	52	51	I	PA.D.EXT		2	43	11	II	EC.D.EXT		11	48	47	II	PA.D.EXT			
	0	56	37	I	PA.D.INT		2	47	54	II	EC.D.INT		11	53	33	II	PA.D.INT			
	2	29	17	I	OM.F.INT		2	47	54	II	EC.D.INT		12	44	33	II	OM.F.INT			
	2	33	5	I	OM.F.EXT		6	22	43	II	OC.F.INT		12	49	20	II	OM.F.EXT			
	3	2	47	I	PA.F.INT		6	27	22	II	OC.F.EXT		14	13	4	II	PA.F.INT			
	3	6	34	I	PA.F.EXT		7	44	51	I	OM.D.EXT		14	17	50	II	PA.F.EXT			
	21	27	56	I	EC.D.PEN		7	48	38	I	OM.D.INT		15	10	26	I	OM.D.EXT			
	21	28	45	I	EC.D.EXT		8	23	27	I	PA.D.EXT		15	14	13	I	OM.D.INT			
	21	32	34	I	EC.D.INT		8	27	14	I	PA.D.INT		15	53	48	I	PA.D.EXT			
	17	0	14	5	I		OC.F.INT	22	4	53	48		I	EC.D.PEN	27	12	19	45	I	EC.D.PEN
		0	17	53	I		OC.F.EXT		4	54	36		I	EC.D.EXT		12	20	33	I	EC.D.EXT
2		36	27	III	OM.D.EXT	4	58		26	I	EC.D.INT	12	24	23		I	EC.D.INT			
2		52	53	III	OM.D.INT	7	45		1	I	OC.F.INT	15	15	54		I	OC.F.INT			
4		30	29	III	OM.F.INT	7	48		50	I	OC.F.EXT	15	19	43		I	OC.F.EXT			
4		47	2	III	OM.F.EXT	21	1		21	II	OM.D.EXT	15	19	43		I	OC.F.EXT			
4		56	48	III	PA.D.EXT	21	6		7	II	OM.D.INT	20	22	15		III	EC.D.PEN			
5		12	38	III	PA.D.INT	22	23		51	II	PA.D.EXT	20	28	3		III	EC.D.EXT			
6		54	36	III	PA.F.INT	22	28		36	II	PA.D.INT	20	46	11		III	EC.D.INT			
7		10	25	III	PA.F.EXT	23	26		21	II	OM.F.INT	22	10	20		III	EC.F.INT			
13		23	53	II	EC.D.PEN	23	31		8	II	OM.F.EXT	22	28	29		III	EC.F.EXT			
13		25	43	II	EC.D.EXT	23	0		48	21	II	PA.F.INT	23	24		37	III	OC.D.EXT		
13		30	26	II	EC.D.INT		0		53	7	II	PA.F.EXT	23	40		38	III	OC.D.INT		
16		58	46	II	OC.F.INT		2		13	23	I	OM.D.EXT	28	1		22	2	III	OC.F.INT	
17		3	25	II	OC.F.EXT		2		17	10	I	OM.D.INT		1		38	4	III	OC.F.EXT	
18		47	44	I	OM.D.EXT		2		53	36	I	PA.D.EXT		5		16	8	II	EC.D.PEN	
18		51	32	I	OM.D.INT		2		57	22	I	PA.D.INT		5		17	58	II	EC.D.EXT	
19		23	4	I	PA.D.EXT		4		23	23	I	OM.F.INT		5		17	58	II	EC.D.EXT	
19		26	51	I	PA.D.INT		4		27	10	I	OM.F.EXT		5		22	40	II	EC.D.INT	
20	57	49	I	OM.F.INT	5		3	22	I	PA.F.INT	9	10		1	II	OC.F.INT				
21	1	37	I	OM.F.EXT	5		7	8	I	PA.F.EXT	9	14		41	II	OC.F.EXT				
21	32	58	I	PA.F.INT	23		22	29	I	EC.D.PEN	9	38		59	I	OM.D.EXT				
21	36	44	I	PA.F.EXT	23		23	18	I	EC.D.EXT	9	42		46	I	OM.D.INT				
18	15	56	33	I	EC.D.PEN		23	27	7	I	EC.D.INT	10		23	54	I	PA.D.EXT			
	15	57	21	I	EC.D.EXT		24	2	15	22	I	OC.F.INT		10	27	41	I	PA.D.INT		
	16	1	11	I	EC.D.INT			2	19	11	I	OC.F.EXT		11	48	54	I	OM.F.INT		
	18	44	24	I	OC.F.INT			6	37	32	III	OM.D.EXT		11	52	41	I	OM.F.EXT		
	18	48	12	I	OC.F.EXT			6	53	52	III	OM.D.INT		12	33	32	I	PA.F.INT		
	19	7	42	22	II			OM.D.EXT	8	31	54	III		OM.F.INT	12	37	19	I	PA.F.EXT	
		7	47	7	II			OM.D.INT	8	48	23	III		OM.F.EXT	29	6	48	19	I	EC.D.PEN
		8	57	58	II	PA.D.EXT		9	25	26	III	PA.D.EXT		6		49	7	I	EC.D.EXT	
		9	2	44	II	PA.D.INT		9	41	22	III	PA.D.INT		6		52	57	I	EC.D.INT	
		10	7	24	II	OM.F.INT		11	22	22	III	PA.F.INT	9	46		3	I	OC.F.INT		
		10	12	10	II	OM.F.EXT		11	38	15	III	PA.F.EXT	9	49		52	I	OC.F.EXT		
		11	22	42	II	PA.F.INT		15	58	45	II	EC.D.PEN	23	38		36	II	OM.D.EXT		
		11	27	27	II	PA.F.EXT		16	0	35	II	EC.D.EXT	23	43		22	II	OM.D.INT		
		13	16	16	I	OM.D.EXT		16	5	18	II	EC.D.INT	30	1		14	21	II	PA.D.EXT	
13		20	4	I	OM.D.INT	19		46	28	II	OC.F.INT	1		19		7	II	PA.D.INT		
13		53	15	I	PA.D.EXT	19	51	7	II	OC.F.EXT	2	3		30		II	OM.F.INT			
13		57	2	I	PA.D.INT	20	41	55	I	OM.D.EXT	2	8		17		II	OM.F.EXT			
15		26	20	I	OM.F.INT	20	45	42	I	OM.D.INT	3	38		25		II	PA.F.INT			
15		30	7	I	OM.F.EXT	21	23	43	I	PA.D.EXT	3	43		12		II	PA.F.EXT			
16	3	6	I	PA.F.INT	21	27	30	I	PA.D.INT	4	7	29		I		OM.D.EXT				
16	6	53	I	PA.F.EXT	22	51	53	I	OM.F.INT	4	7	29		I	OM.D.EXT					
20	10	25	13	I	EC.D.PEN	22	55	41	I	OM.F.EXT	4	11		17	I	OM.D.INT				
	10	26	2	I	EC.D.EXT	23	33	26	I	PA.F.INT	4	53		56	I	PA.D.EXT				
	10	29	51	I	EC.D.INT	23	37	13	I	PA.F.EXT	4	57		43	I	PA.D.INT				
	13	14	46	I	OC.F.INT	25	17	51	5	I	EC.D.PEN	6		17	22	I	OM.F.INT			
	13	18	35	I	OC.F.EXT		17	51	53	I	EC.D.EXT	6		21	10	I	OM.F.EXT			
	16	22	3	III	EC.D.PEN		17	55	43	I	EC.D.INT	7		3	32	I	PA.F.INT			
	16	27	51	III	EC.D.EXT		20	45	36	I	OC.F.INT	7	7	19	I	PA.F.EXT				
	16	46	4	III	EC.D.INT		20	49	25	I	OC.F.EXT									

2012 - CONFIGURATIONS DES SATELLITES GALILÉENS DE JUPITER

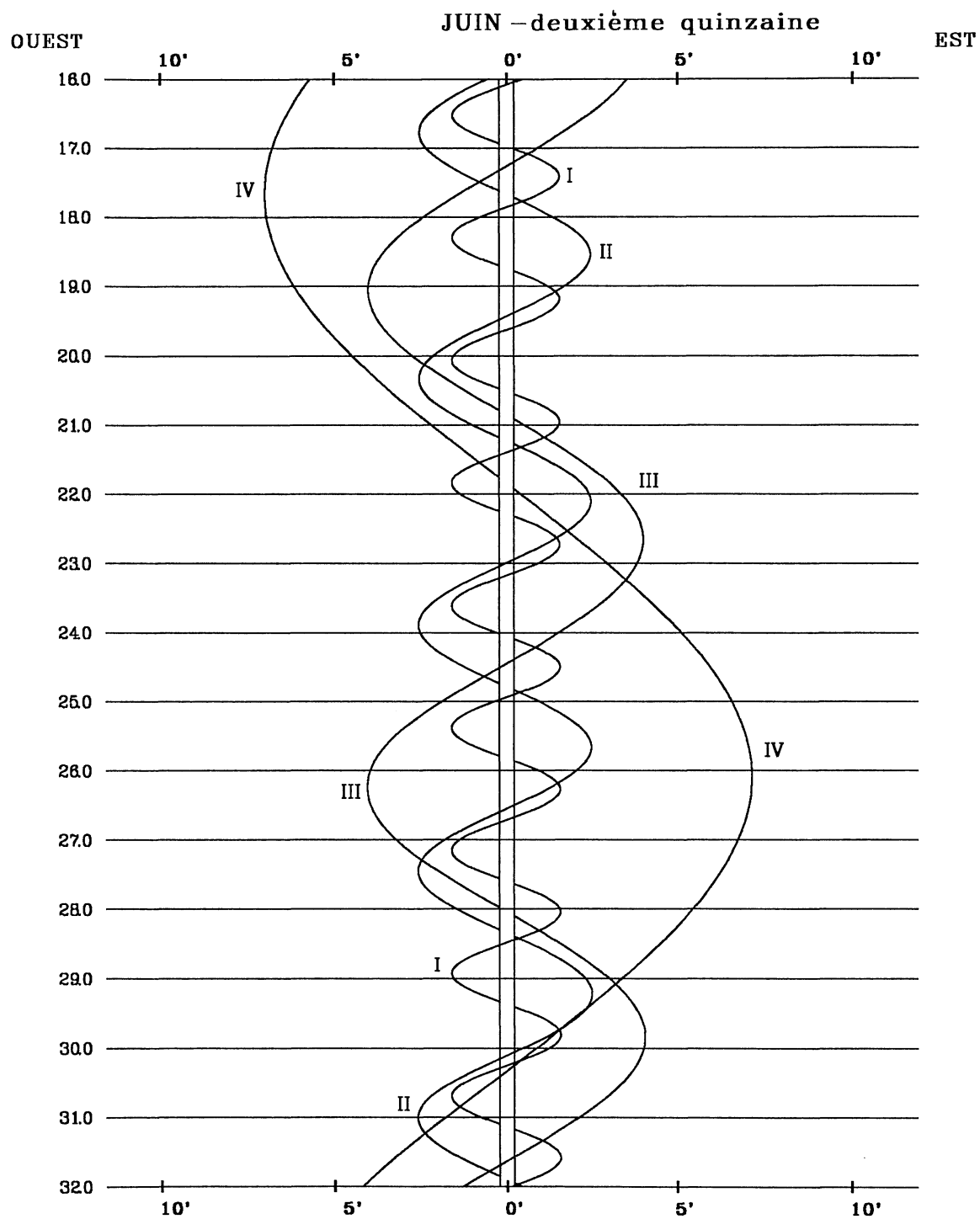

Dans le sens OUEST-EST, les satellites passent au-delà de Jupiter

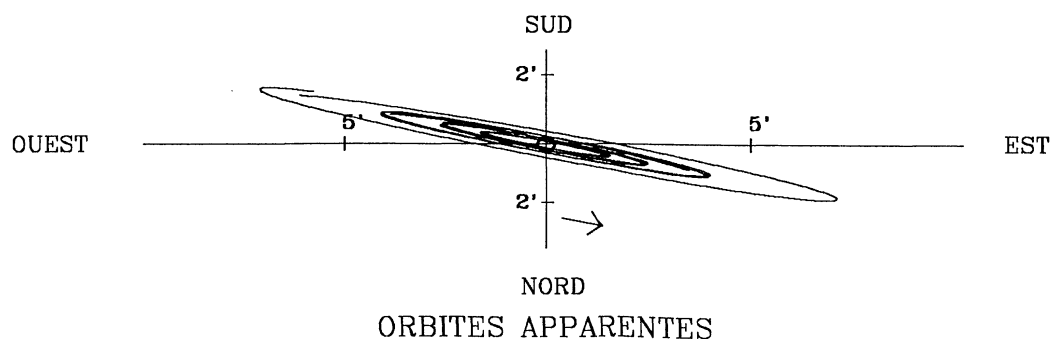

2012 - PHÉNOMÈNES DES SATELLITES GALILÉENS DE JUPITER
(Temps Terrestre)

JUILLET - PREMIÈRE QUINZAINE																	
jour	h	m	s	SAT.	TYPE	jour	h	m	s	SAT.	TYPE	jour	h	m	s	SAT.	TYPE
1	1	16	59	I	EC.D.PEN							21	8	11	I	OM.F.INT	
	1	17	48	I	EC.D.EXT							21	11	58	I	OM.F.EXT	
	1	21	38	I	EC.D.INT							22	2	57	I	PA.F.INT	
	4	16	19	I	OC.F.INT							22	6	43	I	PA.F.EXT	
	4	20	7	I	OC.F.EXT												
	10	37	36	III	OM.D.EXT							11	16	8	39	I	EC.D.PEN
	10	53	51	III	OM.D.INT	6	8	42	46	I	EC.D.PEN		16	9	28	I	EC.D.EXT
	12	32	20	III	OM.F.INT		8	43	35	I	EC.D.EXT		16	13	17	I	EC.D.INT
	12	48	44	III	OM.F.EXT		8	47	25	I	EC.D.INT		19	16	58	I	OC.F.INT
	13	51	45	III	PA.D.EXT		11	46	42	I	OC.F.INT		19	20	46	I	OC.F.EXT
	14	7	47	III	PA.D.INT		11	50	31	I	OC.F.EXT						
	15	47	54	III	PA.F.INT							12	4	23	37	III	EC.D.PEN
	16	3	51	III	PA.F.EXT	7	2	15	53	II	OM.D.EXT		4	29	22	III	EC.D.EXT
	18	33	29	II	EC.D.PEN		2	20	39	II	OM.D.INT		4	47	20	III	EC.D.INT
	18	35	18	II	EC.D.EXT		4	4	9	II	PA.D.EXT		6	12	41	III	EC.F.INT
	18	40	0	II	EC.D.INT		4	8	57	II	PA.D.INT		6	30	39	III	EC.F.EXT
	22	33	23	II	OC.F.INT		4	40	40	II	OM.F.INT		6	36	24	III	EC.F.PEN
	22	36	0	I	OM.D.EXT		4	45	28	II	OM.F.EXT		8	16	11	III	OC.D.EXT
	22	38	3	II	OC.F.EXT		6	1	31	I	OM.D.EXT		8	32	25	III	OC.D.INT
	22	39	47	I	OM.D.INT		6	5	18	I	OM.D.INT		10	12	15	III	OC.F.INT
	23	23	57	I	PA.D.EXT		6	27	48	II	PA.F.INT		10	25	13	II	EC.D.PEN
	23	27	44	I	PA.D.INT		6	32	35	II	PA.F.EXT		10	27	2	II	EC.D.EXT
							6	53	51	I	PA.D.EXT		10	28	29	III	OC.F.EXT
2	0	45	51	I	OM.F.INT		6	57	38	I	PA.D.INT		10	31	44	II	EC.D.INT
	0	49	39	I	OM.F.EXT		8	11	17	I	OM.F.INT		13	26	59	I	OM.D.EXT
	1	33	30	I	PA.F.INT		8	15	4	I	OM.F.EXT		13	30	46	I	OM.D.INT
	1	37	17	I	PA.F.EXT		9	3	16	I	PA.F.INT		14	23	28	I	PA.D.EXT
	19	45	34	I	EC.D.PEN		9	7	3	I	PA.F.EXT		14	27	15	I	PA.D.INT
	19	46	23	I	EC.D.EXT							14	42	7	II	OC.F.INT	
	19	50	12	I	EC.D.INT	8	3	11	26	I	EC.D.PEN		14	46	48	II	OC.F.EXT
	22	46	27	I	OC.F.INT		3	12	15	I	EC.D.EXT		15	36	40	I	OM.F.INT
	22	50	16	I	OC.F.EXT		3	16	4	I	EC.D.INT		15	40	27	I	OM.F.EXT
							6	16	51	I	OC.F.INT		16	32	46	I	PA.F.INT
3	12	56	50	II	OM.D.EXT		6	20	40	I	OC.F.EXT		16	36	32	I	PA.F.EXT
	13	1	36	II	OM.D.INT		14	37	22	III	OM.D.EXT						
	14	38	56	II	PA.D.EXT		14	53	31	III	OM.D.INT	13	10	37	11	I	EC.D.PEN
	14	43	43	II	PA.D.INT		16	32	30	III	OM.F.INT		10	38	0	I	EC.D.EXT
	15	21	41	II	OM.F.INT		16	48	49	III	OM.F.EXT		10	41	49	I	EC.D.INT
	15	26	28	II	OM.F.EXT		18	16	15	III	PA.D.EXT		13	46	54	I	OC.F.INT
	17	2	47	II	PA.F.INT		18	32	21	III	PA.D.INT		13	50	43	I	OC.F.EXT
	17	4	30	I	OM.D.EXT		20	11	40	III	PA.F.INT						
	17	7	34	II	PA.F.EXT		20	27	40	III	PA.F.EXT	14	4	53	12	II	OM.D.EXT
	17	8	17	I	OM.D.INT		21	8	0	II	EC.D.PEN		4	57	58	II	OM.D.INT
	17	53	56	I	PA.D.EXT		21	9	49	II	EC.D.EXT		6	53	11	II	PA.D.EXT
	17	57	43	I	PA.D.INT		21	14	31	II	EC.D.INT		6	58	0	II	PA.D.INT
	19	14	19	I	OM.F.INT							7	17	53	II	OM.F.INT	
	19	18	7	I	OM.F.EXT	9	0	30	0	I	OM.D.EXT		7	22	40	II	OM.F.EXT
	20	3	26	I	PA.F.INT		0	33	47	I	OM.D.INT		7	55	27	I	OM.D.EXT
	20	7	13	I	PA.F.EXT		1	19	26	II	OC.F.INT		7	59	14	I	OM.D.INT
							1	23	45	I	PA.D.EXT		8	53	16	I	PA.D.EXT
4	14	14	14	I	EC.D.PEN		1	24	6	II	OC.F.EXT		8	57	3	I	PA.D.INT
	14	15	2	I	EC.D.EXT		1	27	32	I	PA.D.INT		9	16	24	II	PA.F.INT
	14	18	52	I	EC.D.INT		2	39	44	I	OM.F.INT		9	21	12	II	PA.F.EXT
	17	16	39	I	OC.F.INT		2	43	32	I	OM.F.EXT		10	5	6	I	OM.F.INT
	17	20	28	I	OC.F.EXT		3	33	8	I	PA.F.INT		10	8	54	I	OM.F.EXT
							3	36	54	I	PA.F.EXT		11	2	32	I	PA.F.INT
5	0	23	11	III	EC.D.PEN		21	40	0	I	EC.D.PEN		11	6	18	I	PA.F.EXT
	0	28	57	III	EC.D.EXT		21	40	49	I	EC.D.EXT						
	0	47	1	III	EC.D.INT		21	44	38	I	EC.D.INT	15	5	5	50	I	EC.D.PEN
	2	11	43	III	EC.F.INT							5	6	39	I	EC.D.EXT	
	2	29	47	III	EC.F.EXT	10	0	46	53	I	OC.F.INT		5	10	28	I	EC.D.INT
	2	35	33	III	EC.F.PEN		0	50	41	I	OC.F.EXT		8	16	56	I	OC.F.INT
	3	51	28	III	OC.D.EXT		15	34	9	II	OM.D.EXT		8	20	44	I	OC.F.EXT
	4	7	37	III	OC.D.INT		15	38	55	II	OM.D.INT		18	36	57	III	OM.D.EXT
	5	48	10	III	OC.F.INT		17	28	23	II	PA.D.EXT		18	53	0	III	OM.D.INT
	6	4	18	III	OC.F.EXT		17	33	11	II	PA.D.INT		20	32	27	III	OM.F.INT
	7	50	46	II	EC.D.PEN		17	58	53	II	OM.F.INT		20	48	42	III	OM.F.EXT
	7	52	35	II	EC.D.EXT		18	3	40	II	OM.F.EXT		22	38	56	III	PA.D.EXT
	7	57	18	II	EC.D.INT		18	58	29	I	OM.D.EXT		22	55	8	III	PA.D.INT
	11	33	1	I	OM.D.EXT		19	2	16	I	OM.D.INT		23	42	22	II	EC.D.PEN
	11	36	49	I	OM.D.INT		19	51	48	II	PA.F.INT		23	44	11	II	EC.D.EXT
	11	56	32	II	OC.F.INT		19	53	36	I	PA.D.EXT		23	48	54	II	EC.D.INT
	12	1	12	II	OC.F.EXT		19	56	35	II	PA.F.EXT						
	12	23	55	I	PA.D.EXT		19	57	23	I	PA.D.INT						

2012 – CONFIGURATIONS DES SATELLITES GALILÉENS DE JUPITER

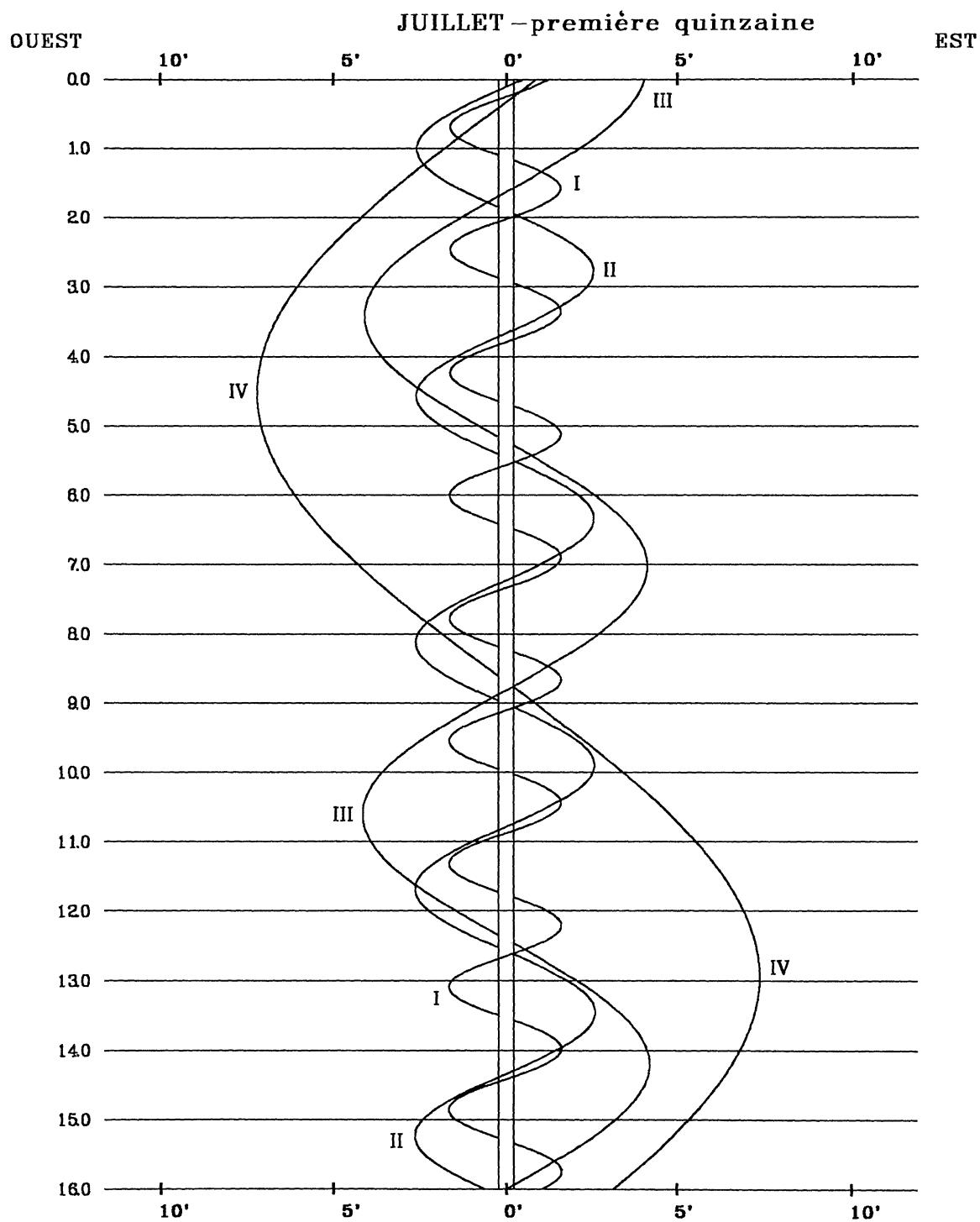

Dans le sens OUEST–EST, les satellites passent au-delà de Jupiter

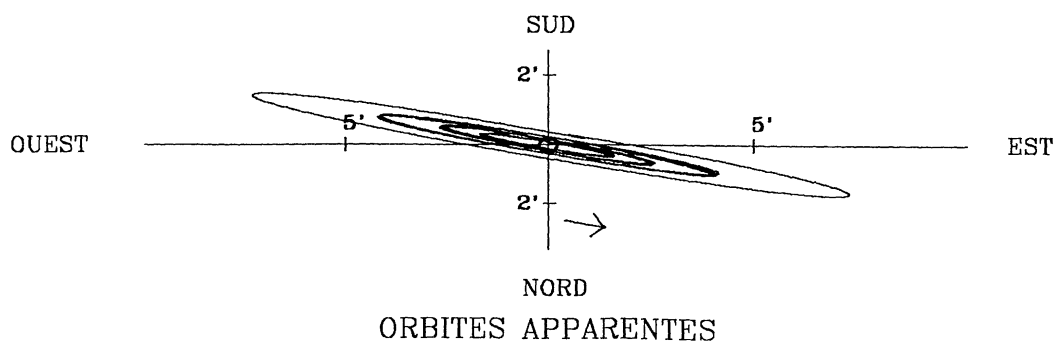

2012 - PHÉNOMÈNES DES SATELLITES GALILÉENS DE JUPITER
(Temps Terrestre)

JUILLET - DEUXIÈME QUINZAINE																				
jour	h	m	s	SAT.	TYPE	jour	h	m	s	SAT.	TYPE	jour	h	m	s	SAT.	TYPE			
16	0	33	39	III	PA.F.INT	22	9	53	6	I	OM.D.INT	27	15	40	15	II	EC.D.INT			
	0	49	43	III	PA.F.EXT		9	55	4	II	OM.F.INT		16	59	43	III	OC.D.EXT			
	2	23	55	I	OM.D.EXT		9	59	52	II	OM.F.EXT		17	14	40	I	OM.D.EXT			
	2	27	42	I	OM.D.INT		10	52	10	I	PA.D.EXT		17	16	5	III	OC.D.INT			
	3	23	2	I	PA.D.EXT		10	55	57	I	PA.D.INT		17	18	26	I	OM.D.INT			
	3	26	49	I	PA.D.INT		11	58	51	I	OM.F.INT		18	20	56	I	PA.D.EXT			
	4	4	33	II	OC.F.INT		12	2	38	I	OM.F.EXT		18	24	43	I	PA.D.INT			
	4	9	13	II	OC.F.EXT		12	4	2	II	PA.F.INT		18	54	44	III	OC.F.INT			
	4	33	33	I	OM.F.INT		12	8	50	II	PA.F.EXT		19	11	6	III	OC.F.EXT			
	4	37	20	I	OM.F.EXT		13	1	16	I	PA.F.INT		19	24	7	I	OM.F.INT			
	5	32	15	I	PA.F.INT		13	5	2	I	PA.F.EXT		19	27	54	I	OM.F.EXT			
	5	36	2	I	PA.F.EXT								20	10	15	II	OC.F.INT			
	23	34	23	I	EC.D.PEN		7	0	11	I	EC.D.PEN		20	14	56	II	OC.F.EXT			
	23	35	12	I	EC.D.EXT		7	1	0	I	EC.D.EXT		20	29	55	I	PA.F.INT			
	23	39	2	I	EC.D.INT		7	4	49	I	EC.D.INT		20	33	42	I	PA.F.EXT			
							10	16	29	I	OC.F.INT									
	17	2	46	50	I		OC.F.INT	10	20	18	I		OC.F.EXT	28	10	7	48	II	OM.D.EXT	
		2	50	39	I		OC.F.EXT	22	36	37	III		OM.D.EXT		10	12	34	II	OM.D.INT	
		18	11	26	II		OM.D.EXT	22	52	34	III		OM.D.INT		11	43	6	I	OM.D.EXT	
		18	16	12	II		OM.D.INT								11	46	53	I	OM.D.INT	
		20	16	55	II		PA.D.EXT	23	0	32	32		III		OM.F.INT	12	28	13	II	PA.D.EXT
		20	21	44	II		PA.D.INT	0	48	42	III		OM.F.EXT		12	32	17	II	OM.F.INT	
		20	36	3	II		OM.F.INT	2	16	38	II		EC.D.PEN		12	33	2	II	PA.D.INT	
20		40	51	II	OM.F.EXT	2	18	27	II	EC.D.EXT	12	37	5		II	OM.F.EXT				
20		52	23	I	OM.D.EXT	2	23	9	II	EC.D.INT	12	50	28		I	PA.D.EXT				
20		56	9	I	OM.D.INT	2	59	45	III	PA.D.EXT	12	54	15		I	PA.D.INT				
21		52	46	I	PA.D.EXT	3	16	1	III	PA.D.INT	13	52	32		I	OM.F.INT				
21		56	33	I	PA.D.INT	4	17	46	I	OM.D.EXT	13	56	19		I	OM.F.EXT				
22		39	54	II	PA.F.INT	4	21	33	I	OM.D.INT	14	50	36		II	PA.F.INT				
22		44	42	II	PA.F.EXT	4	21	33	I	OM.D.INT	14	55	24		II	PA.F.EXT				
23		1	58	I	OM.F.INT	4	53	48	III	PA.F.INT	14	59	25		I	PA.F.INT				
23		5	45	I	OM.F.EXT	5	9	56	III	PA.F.EXT	15	3	11		I	PA.F.EXT				
						5	21	47	I	PA.D.EXT										
18		0	1	57	I	PA.F.INT	5	25	34	I	PA.D.INT	29	8		54	29	I	EC.D.PEN		
		0	5	43	I	PA.F.EXT	6	27	16	I	OM.F.INT		8		55	18	I	EC.D.EXT		
		18	3	2	I	EC.D.PEN	6	31	4	I	OM.F.EXT		8		59	7	I	EC.D.INT		
		18	3	50	I	EC.D.EXT	6	48	38	II	OC.F.INT		12		15	26	I	OC.F.INT		
		18	7	40	I	EC.D.INT	6	53	19	II	OC.F.EXT		12		19	15	I	OC.F.EXT		
		21	16	47	I	OC.F.INT	7	30	51	I	PA.F.INT									
	21	20	36	I	OC.F.EXT	7	34	37	I	PA.F.EXT										
	19	8	24	31	III	EC.D.PEN	24	1	28	44	I		EC.D.PEN	30	2	36	55	III	OM.D.EXT	
		8	30	14	III	EC.D.EXT	1	29	32	I	EC.D.EXT		2		52	46	III	OM.D.INT		
		8	48	5	III	EC.D.INT	1	33	22	I	EC.D.INT		4		33	16	III	OM.F.INT		
10		14	11	III	EC.F.INT	4	46	14	I	OC.F.INT	4	49	21		III	OM.F.EXT				
10		32	3	III	EC.F.EXT	4	50	3	I	OC.F.EXT	4	50	46		II	EC.D.PEN				
10		37	46	III	EC.F.PEN	20	48	43	II	OM.D.EXT	4	52	35		II	EC.D.EXT				
12		39	26	III	OC.D.EXT	20	53	29	II	OM.D.INT	4	57	16		II	EC.D.INT				
12		55	44	III	OC.D.INT	22	46	12	I	OM.D.EXT	6	11	32		I	OM.D.EXT				
12		59	33	II	EC.D.PEN	22	49	59	I	OM.D.INT	6	15	18		I	OM.D.INT				
13		1	22	II	EC.D.EXT	23	4	25	II	PA.D.EXT	7	19	1		III	PA.D.EXT				
13		6	4	II	EC.D.INT	23	9	15	II	PA.D.INT	7	19	56		I	PA.D.EXT				
14		34	57	III	OC.F.INT	23	13	14	II	OM.F.INT	7	23	43		I	PA.D.INT				
14		51	16	III	OC.F.EXT	23	18	2	II	OM.F.EXT	7	35	21		III	PA.D.INT				
15		20	52	I	OM.D.EXT	23	51	22	I	PA.D.EXT	8	20	56		I	OM.F.INT				
15		24	38	I	OM.D.INT	23	55	9	I	PA.D.INT	8	24	44		I	OM.F.EXT				
16		22	29	I	PA.D.EXT						9	12	27		III	PA.F.INT				
16		26	16	I	PA.D.INT	25	0	55	41	I	OM.F.INT	9	28		38	III	PA.F.EXT			
17		26	45	II	OC.F.INT	0	59	28	I	OM.F.EXT	9	28	51		I	PA.F.INT				
17		30	25	I	OM.F.INT	1	27	0	II	PA.F.INT	9	31	34		II	OC.F.INT				
17		31	26	II	OC.F.EXT	1	31	49	II	PA.F.EXT	9	32	37		I	PA.F.EXT				
17		34	12	I	OM.F.EXT	2	0	23	I	PA.F.INT	9	36	15		II	OC.F.EXT				
18		31	37	I	PA.F.INT	2	4	10	I	PA.F.EXT										
18		35	24	I	PA.F.EXT	19	57	21	I	EC.D.PEN										
					19	58	10	I	EC.D.EXT											
20	12	31	33	I	EC.D.PEN	20	1	59	I	EC.D.INT	31	3	23	1	I	EC.D.PEN				
	12	32	21	I	EC.D.EXT	23	16	3	I	OC.F.INT		3	23	50	I	EC.D.EXT				
	12	36	11	I	EC.D.INT	23	19	52	I	OC.F.EXT		3	27	39	I	EC.D.INT				
	15	46	35	I	OC.F.INT							6	45	3	I	OC.F.INT				
	15	50	24	I	OC.F.EXT							6	48	52	I	OC.F.EXT				
21	7	30	29	II	OM.D.EXT	26	12	24	33	III	EC.D.PEN	23	25	59	II	OM.D.EXT				
	7	35	15	II	OM.D.INT	12	30	15	III	EC.D.EXT	23	30	45	II	OM.D.INT					
	9	41	14	II	PA.D.EXT	12	47	59	III	EC.D.INT										
	9	46	3	II	PA.D.INT	14	14	52	III	EC.F.INT										
	9	49	19	I	OM.D.EXT	14	32	36	III	EC.F.EXT										
						14	38	18	III	EC.F.PEN										

2012 - CONFIGURATIONS DES SATELLITES GALILÉENS DE JUPITER

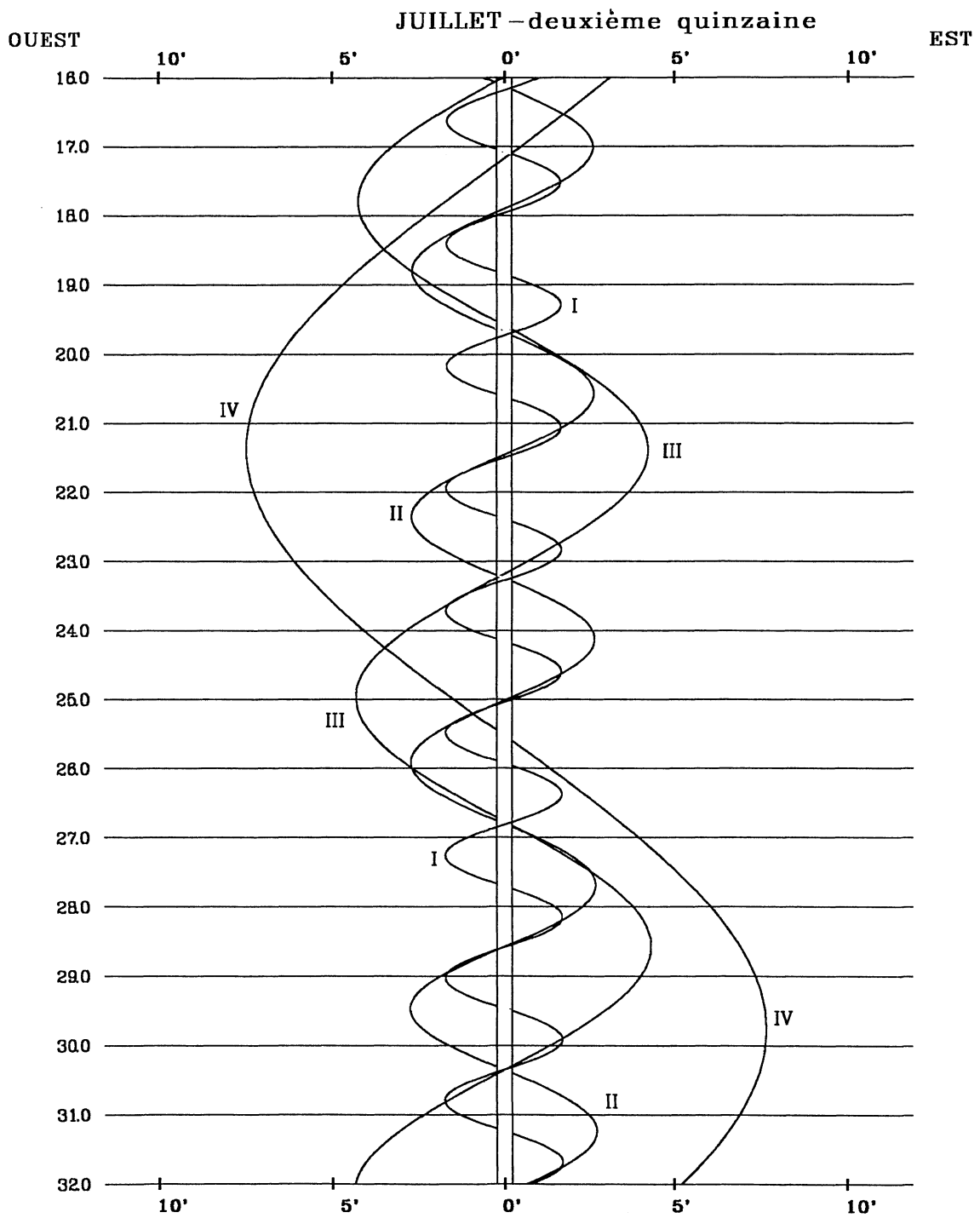

Dans le sens OUEST-EST, les satellites passent au-delà de Jupiter

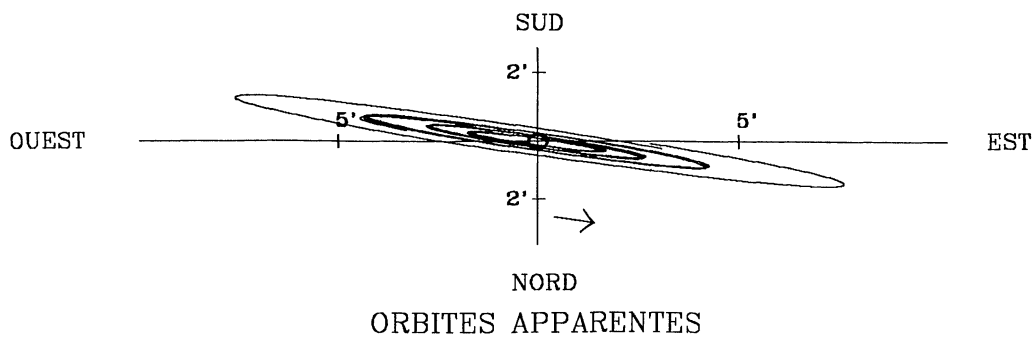

2012 - PHÉNOMÈNES DES SATELLITES GALILÉENS DE JUPITER
(Temps Terrestre)

AOÛT - DEUXIÈME QUINZAINE																			
jour	h	m	s	SAT.	TYPE	jour	h	m	s	SAT.	TYPE	jour	h	m	s	SAT.	TYPE		
16	1	40	5	I	EC.D.PEN	21	9	5	39	I	EC.D.PEN	27	13	45	56	I	OM.D.EXT		
	1	40	53	I	EC.D.EXT		9	6	27	I	EC.D.EXT		13	49	43	I	OM.D.INT		
	1	44	42	I	EC.D.INT		9	10	17	I	EC.D.INT		15	5	25	I	PA.D.EXT		
	5	9	52	I	OC.F.INT		12	37	11	I	OC.F.INT		15	6	43	II	EC.D.PEN		
	5	13	41	I	OC.F.EXT		12	40	59	I	OC.F.EXT		15	8	31	II	EC.D.EXT		
	22	55	39	I	OM.D.EXT		22	6	20	48	I		OM.D.EXT	15	9	12	I	PA.D.INT	
	22	59	25	I	OM.D.INT			6	24	34	I		OM.D.INT	15	13	13	II	EC.D.INT	
	23	15	47	II	EC.D.PEN			7	17	32	II		OM.D.EXT	15	55	10	I	OM.F.INT	
	23	17	36	II	EC.D.EXT			7	22	17	II		OM.D.INT	15	58	57	I	OM.F.EXT	
	23	22	17	II	EC.D.INT			7	39	6	I		PA.D.EXT	17	13	57	I	PA.F.INT	
	17	0	12	19	I			PA.D.EXT	7	42	53		I	PA.D.INT	17	17	43	I	PA.F.EXT
		0	16	6	I			PA.D.INT	8	30	1		I	OM.F.INT	17	29	29	II	EC.F.INT
		0	23	43	III			EC.D.PEN	8	32	48		I	OM.F.EXT	17	34	11	II	EC.F.EXT
0		29	20	III	EC.D.EXT	9		41	47	II	OM.F.INT	17	35	59	II	EC.F.PEN			
0		46	42	III	EC.D.INT	9		46	34	II	OM.F.EXT	17	48	17	II	OC.D.EXT			
1		4	53	I	OM.F.INT	9		47	40	I	PA.F.INT	17	53	0	II	OC.D.INT			
1		8	40	I	OM.F.EXT	9		51	27	I	PA.F.EXT	18	35	36	III	OM.D.EXT			
1		38	27	II	EC.F.INT	10		1	7	II	PA.D.EXT	18	51	1	III	OM.D.INT			
1		43	9	II	EC.F.EXT	10	5	59	II	PA.D.INT	20	9	48	II	OC.F.INT				
1		44	57	II	EC.F.PEN	12	22	15	II	PA.F.INT	20	14	32	II	OC.F.EXT				
1		51	27	II	OC.D.EXT	12	27	5	II	PA.F.EXT	20	34	18	III	OM.F.INT				
1		56	9	II	OC.D.INT	23	3	34	15	I	EC.D.PEN	20	50	0	III	OM.F.EXT			
2		16	6	III	EC.F.INT		3	35	3	I	EC.D.EXT	28	0	5	14	III	PA.D.EXT		
2		20	57	I	PA.F.INT		3	38	52	I	EC.D.INT		0	21	48	III	PA.D.INT		
2		24	43	I	PA.F.EXT		7	6	15	I	OC.F.INT		1	56	39	III	PA.F.INT		
2		33	29	III	EC.F.EXT		7	10	4	I	OC.F.EXT		2	12	58	III	PA.F.EXT		
2		39	6	III	EC.F.PEN		24	0	49	11	I		OM.D.EXT	10	59	47	I	EC.D.PEN	
4		13	14	II	OC.F.INT			0	52	57	I		OM.D.INT	11	0	36	I	EC.D.EXT	
4		17	57	II	OC.F.EXT			1	49	44	II		EC.D.PEN	11	4	25	I	EC.D.INT	
5		44	25	III	OC.D.EXT			1	51	33	II		EC.D.EXT	14	32	53	I	OC.F.INT	
6		0	58	III	OC.D.INT			1	56	15	II		EC.D.INT	14	36	42	I	OC.F.EXT	
7		38	2	III	OC.F.INT			2	7	56	I		PA.D.EXT	29	8	14	18	I	OM.D.EXT
7		54	35	III	OC.F.EXT			2	11	43	I		PA.D.INT		8	18	4	I	OM.D.INT
20	8	33	I	EC.D.PEN	2			58	24	I	OM.F.INT		9		34	4	I	PA.D.EXT	
20	9	22	I	EC.D.EXT	3	2		11	I	OM.F.EXT	9		37		51	I	PA.D.INT		
20	13	11	I	EC.D.INT	4	12		28	II	EC.F.INT	9	54	36		II	OM.D.EXT			
23	38	58	I	OC.F.INT	4	16		29	I	PA.F.INT	9	59	21		II	OM.D.INT			
23	42	47	I	OC.F.EXT	4	17		10	II	EC.F.EXT	10	23	32		I	OM.F.INT			
18	17	24	3	I	OM.D.EXT	4		18	58	II	EC.F.PEN	10	27		19	I	OM.F.EXT		
	17	27	49	I	OM.D.INT	4	20	15	I	PA.F.EXT	10	42	35		I	PA.F.INT			
	17	59	26	II	OM.D.EXT	4	24	10	III	EC.D.PEN	11	46	22		I	PA.F.EXT			
	18	4	11	II	OM.D.INT	4	29	45	II	OC.D.EXT	12	18	51		II	OM.F.INT			
	18	41	19	I	PA.D.EXT	4	29	46	III	EC.D.EXT	12	23	38		II	OM.F.EXT			
	18	45	6	I	PA.D.INT	4	34	28	II	OC.D.INT	12	41	11		II	PA.D.EXT			
	19	33	17	I	OM.F.INT	4	47	0	III	EC.D.INT	12	46	2	II	PA.D.INT				
	19	37	4	I	OM.F.EXT	6	17	17	III	EC.F.INT	15	2	1	II	PA.F.INT				
	20	23	42	II	OM.F.INT	6	34	32	III	EC.F.EXT	15	6	50	II	PA.F.EXT				
	20	28	29	II	OM.F.EXT	6	40	8	III	EC.F.PEN	30	5	28	23	I	EC.D.PEN			
	20	40	51	II	PA.D.EXT	6	51	21	II	OC.F.INT		5	29	11	I	EC.D.EXT			
	20	45	42	II	PA.D.INT	6	56	4	II	OC.F.EXT		5	33	0	I	EC.D.INT			
	20	49	56	I	PA.F.INT	9	54	2	III	OC.D.EXT		9	1	43	I	OC.F.INT			
	20	53	42	I	PA.F.EXT	10	10	39	III	OC.D.INT		9	5	32	I	OC.F.EXT			
	23	2	9	II	PA.F.INT	11	47	10	III	OC.F.INT		31	2	42	41	I	OM.D.EXT		
	23	6	58	II	PA.F.EXT	12	3	47	III	OC.F.EXT			2	46	27	I	OM.D.INT		
	19	14	37	9	I	EC.D.PEN	22	2	43	I			EC.D.PEN	4	2	40	I	PA.D.EXT	
		14	37	57	I	EC.D.EXT	22	3	31	I			EC.D.EXT	4	6	27	I	PA.D.INT	
		14	41	47	I	EC.D.INT	22	7	20	I			EC.D.INT	4	23	39	II	EC.D.PEN	
		18	8	9	I	OC.F.INT	25	1	35	8			I	OC.F.INT	4	25	28	II	EC.D.EXT
		18	11	58	I	OC.F.EXT		1	38	57			I	OC.F.EXT	4	30	9	II	EC.D.INT
		20	11	52	25	I		OM.D.EXT	19	17			35	I	OM.D.EXT	4	51	55	I
			11	56	12	I		OM.D.INT	19	21	21		I	OM.D.INT	4	55	42	I	OM.F.EXT
12			32	48	II	EC.D.PEN		20	36	30	II		OM.D.EXT	6	11	11	I	PA.F.INT	
12			34	36	II	EC.D.EXT		20	36	43	I		PA.D.EXT	6	14	57	I	PA.F.EXT	
12			39	18	II	EC.D.INT		20	40	30	I		PA.D.INT	6	46	27	II	EC.F.INT	
13			10	14	I	PA.D.EXT		20	41	15	II		OM.D.INT	6	51	9	II	EC.F.EXT	
13			14	1	I	PA.D.INT		21	26	48	I	OM.F.INT	6	52	58	II	EC.F.PEN		
14			1	39	I	OM.F.INT		21	30	35	I	OM.F.EXT	7	6	20	II	OC.D.EXT		
14	5		26	I	OM.F.EXT	22		45	15	I	PA.F.INT	7	11	4	II	OC.D.INT			
14	36		29	III	OM.D.EXT	22		49	2	I	PA.F.EXT	8	24	8	III	EC.D.PEN			
14	52		1	III	OM.D.INT	23		0	45	II	OM.F.INT	8	29	41	III	EC.D.EXT			
14	55		29	II	EC.F.INT	23	5	32	II	OM.F.EXT	8	46	48	III	EC.D.INT				
15	0		11	II	EC.F.EXT	23	21	48	II	PA.D.EXT	9	27	46	II	OC.F.INT				
15	2		0	II	EC.F.PEN	23	26	39	II	PA.D.INT	9	32	30	II	OC.F.EXT				
15	10		50	II	OC.D.EXT	26	1	42	46	II	PA.F.INT	10	18	2	III	EC.F.INT			
15	15		33	II	OC.D.INT		1	47	36	II	PA.F.EXT	10	35	9	III	EC.F.EXT			
15	18		49	I	PA.F.INT		16	31	18	I	EC.D.PEN	10	40	43	III	EC.F.PEN			
15	22		36	I	PA.F.EXT		16	32	6	I	EC.D.EXT	13	59	28	III	OC.D.EXT			
16	34		32	III	OM.F.INT		16	35	55	I	EC.D.INT	14	16	9	III	OC.D.INT			
16	50		20	III	OM.F.EXT		20	4	5	I	OC.F.INT	15	52	7	III	OC.F.INT			
17	32		32	II	OC.F.INT		20	7	54	I	OC.F.EXT	16	8	48	III	OC.F.EXT			
17	37		15	II	OC.F.EXT		20	1	42	46	II	PA.F.INT	23	56	50	I	EC.D.PEN		
19	59		1	III	PA.D.EXT			1	47	36	II	PA.F.EXT	23	57	39	I	EC.D.EXT		
20	15	31	III	PA.D.INT	16			31	18	I	EC.D.PEN								
21	50	55	III	PA.F.INT	16			32	6	I	EC.D.EXT								

2012 - PHÉNOMÈNES DES SATELLITES GALILÉENS DE JUPITER
(Temps Terrestre)

SEPTEMBRE - PREMIÈRE QUINZAINE																	
jour	h	m	s	SAT.	TYPE	jour	h	m	s	SAT.	TYPE	jour	h	m	s	SAT.	TYPE
1	0	1	28	I	EC.D.INT	7	23	18	I	EC.D.EXT	23	2	38	II	OC.D.INT		
	3	30	23	I	OC.F.INT		7	27	7	I	EC.D.INT						
	3	34	12	I	OC.F.EXT		10	56	15	I	OC.F.INT	11	1	19	5	II	OC.F.INT
	21	11	4	I	OM.D.EXT		11	0	4	I	OC.F.EXT		1	23	49	II	OC.F.EXT
	21	14	50	I	OM.D.INT								2	33	42	III	OM.D.EXT
	22	31	15	I	PA.D.EXT	7	4	36	8	I	OM.D.EXT		2	48	56	III	OM.D.INT
	22	35	2	I	PA.D.INT		4	39	54	I	OM.D.INT		4	33	51	III	OM.F.INT
	23	13	32	II	OM.D.EXT		5	56	30	I	PA.D.EXT		4	49	22	III	OM.F.EXT
	23	18	16	II	OM.D.INT		6	0	17	I	PA.D.INT		8	6	40	III	PA.D.EXT
	23	20	19	I	OM.F.INT		6	45	25	I	OM.F.INT		8	23	22	III	PA.D.INT
	23	24	5	I	OM.F.EXT		6	49	12	I	OM.F.EXT		9	56	58	III	PA.F.INT
							6	57	38	II	EC.D.PEN		10	13	26	III	PA.F.EXT
2	0	39	45	I	PA.F.INT		6	59	26	II	EC.D.EXT		14	48	0	I	EC.D.PEN
	0	43	31	I	PA.F.EXT		7	4	8	II	EC.D.INT		14	48	48	I	EC.D.EXT
	1	37	46	II	OM.F.INT		8	4	59	I	PA.F.INT		14	52	37	I	EC.D.INT
	1	42	33	II	OM.F.EXT		8	8	46	I	PA.F.EXT		18	21	25	I	OC.F.INT
	2	0	53	II	PA.D.EXT		9	20	32	II	EC.F.INT		18	25	13	I	OC.F.EXT
	2	5	44	II	PA.D.INT		9	25	13	II	EC.F.EXT						
	4	21	34	II	PA.F.INT		9	27	2	II	EC.F.PEN	12	12	1	12	I	OM.D.EXT
	4	26	24	II	PA.F.EXT		9	41	11	II	OC.D.EXT		12	4	58	I	OM.D.INT
	18	25	25	I	EC.D.PEN		9	45	55	II	OC.D.INT		13	21	15	I	PA.D.EXT
	18	26	13	I	EC.D.EXT		12	2	27	II	OC.F.INT		13	25	2	I	PA.D.INT
	18	30	2	I	EC.D.INT		12	7	11	II	OC.F.EXT		14	10	33	I	OM.F.INT
	21	59	5	I	OC.F.INT		12	24	32	III	EC.D.PEN		14	14	20	I	OM.F.EXT
	22	2	54	I	OC.F.EXT		12	30	4	III	EC.D.EXT		15	8	25	II	OM.D.EXT
							12	47	1	III	EC.D.INT		15	13	9	II	OM.D.INT
3	15	39	25	I	OM.D.EXT		14	19	18	III	EC.F.INT		15	29	45	I	PA.F.INT
	15	43	11	I	OM.D.INT		14	36	16	III	EC.F.EXT		15	33	31	I	PA.F.EXT
	16	59	43	I	PA.D.EXT		14	41	47	III	EC.F.PEN		17	32	44	II	OM.F.INT
	17	3	30	I	PA.D.INT		18	1	23	III	OC.D.EXT		17	37	31	II	OM.F.EXT
	17	40	39	II	EC.D.PEN		18	18	7	III	OC.D.INT		17	55	12	II	PA.D.EXT
	17	42	27	II	EC.D.EXT		19	53	34	III	OC.F.INT		18	0	3	II	PA.D.INT
	17	47	9	II	EC.D.INT		20	10	18	III	OC.F.EXT		20	15	32	II	PA.F.INT
	17	48	40	I	OM.F.INT								20	20	22	II	PA.F.EXT
	17	52	27	I	OM.F.EXT	8	1	50	57	I	EC.D.PEN						
	19	8	13	I	PA.F.INT		1	51	45	I	EC.D.EXT	13	9	16	35	I	EC.D.PEN
	19	11	59	I	PA.F.EXT		1	55	34	I	EC.D.INT		9	17	23	I	EC.D.EXT
	20	3	30	II	EC.F.INT		5	24	39	I	OC.F.INT		9	21	12	I	EC.D.INT
	20	8	12	II	EC.F.EXT		5	28	28	I	OC.F.EXT		12	49	44	I	OC.F.INT
	20	10	0	II	EC.F.PEN		23	4	31	I	OM.D.EXT		12	53	33	I	OC.F.EXT
	20	24	0	II	OC.D.EXT		23	8	17	I	OM.D.INT						
	20	28	44	II	OC.D.INT	9	0	24	50	I	PA.D.EXT	14	6	29	34	I	OM.D.EXT
	22	34	35	III	OM.D.EXT		0	28	37	I	PA.D.INT		6	33	20	I	OM.D.INT
	22	45	21	II	OC.F.INT		1	13	49	I	OM.F.INT		7	49	21	I	PA.D.EXT
	22	49	55	III	OM.D.INT		1	17	36	I	OM.F.EXT		7	53	8	I	PA.D.INT
	22	50	5	II	OC.F.EXT		1	17	36	I	OM.F.EXT		8	38	56	I	OM.F.INT
							1	50	25	II	OM.D.EXT		8	42	42	I	OM.F.EXT
4	0	33	59	III	OM.F.INT		1	55	10	II	OM.D.INT		9	31	37	II	EC.D.PEN
	0	49	35	III	OM.F.EXT		2	33	20	I	PA.F.INT		9	33	26	II	EC.D.EXT
	4	7	51	III	PA.D.EXT		2	37	6	I	PA.F.EXT		9	38	7	II	EC.D.INT
	4	24	29	III	PA.D.INT		4	14	42	II	OM.F.INT		9	57	51	I	PA.F.INT
	5	58	43	III	PA.F.INT		4	19	29	II	OM.F.EXT		10	1	38	I	PA.F.EXT
	6	15	6	III	PA.F.EXT		4	37	53	II	PA.D.EXT		11	54	38	II	EC.F.INT
	12	53	54	I	EC.D.PEN		4	42	45	II	PA.D.INT		11	59	19	II	EC.F.EXT
	12	54	43	I	EC.D.EXT		6	58	20	II	PA.F.INT		12	1	8	II	EC.F.PEN
	12	58	32	I	EC.D.INT		7	3	10	II	PA.F.EXT		12	14	4	II	OC.D.EXT
	16	27	39	I	OC.F.INT		20	19	31	I	EC.D.PEN		12	18	49	II	OC.D.INT
	16	31	28	I	OC.F.EXT		20	20	19	I	EC.D.EXT		14	35	11	II	OC.F.INT
							20	24	8	I	EC.D.INT		14	39	56	II	OC.F.EXT
5	10	7	46	I	OM.D.EXT		23	53	6	I	OC.F.INT		16	24	8	III	EC.D.PEN
	10	11	32	I	OM.D.INT		23	56	55	I	OC.F.EXT		16	29	37	III	EC.D.EXT
	11	28	8	I	PA.D.EXT	10	17	32	51	I	OM.D.EXT		16	46	26	III	EC.D.INT
	11	31	55	I	PA.D.INT		17	36	37	I	OM.D.INT		18	19	46	III	EC.F.INT
	12	17	2	I	OM.F.INT		17	36	37	I	OM.D.INT		18	36	35	III	EC.F.EXT
	12	20	49	I	OM.F.EXT		18	53	4	I	PA.D.EXT		18	42	4	III	EC.F.PEN
	12	31	33	II	OM.D.EXT		18	56	51	I	PA.D.INT		21	58	22	III	OC.D.EXT
	12	36	18	II	OM.D.INT		19	42	11	I	OM.F.INT		22	15	10	III	OC.D.INT
	13	36	38	I	PA.F.INT		19	45	57	I	OM.F.EXT		23	50	1	III	OC.F.INT
	13	40	24	I	PA.F.EXT		20	14	38	II	EC.D.PEN						
	14	55	49	II	OM.F.INT		20	16	27	II	EC.D.EXT	15	0	6	49	III	OC.F.EXT
	15	0	36	II	OM.F.EXT		20	21	8	II	EC.D.INT		3	45	2	I	EC.D.PEN
	15	19	15	II	PA.D.EXT		21	1	33	I	PA.F.INT		3	45	50	I	EC.D.EXT
	15	24	6	II	PA.D.INT		21	5	20	I	PA.F.EXT		3	49	39	I	EC.D.INT
	17	39	49	II	PA.F.INT		22	37	35	II	EC.F.INT		7	17	53	I	OC.F.INT
	17	44	38	II	PA.F.EXT		22	42	17	II	EC.F.EXT		7	21	42	I	OC.F.EXT
							22	44	6	II	EC.F.PEN						
6	7	22	29	I	EC.D.PEN		22	57	53	II	OC.D.EXT						

2012 - CONFIGURATIONS DES SATELLITES GALILÉENS DE JUPITER

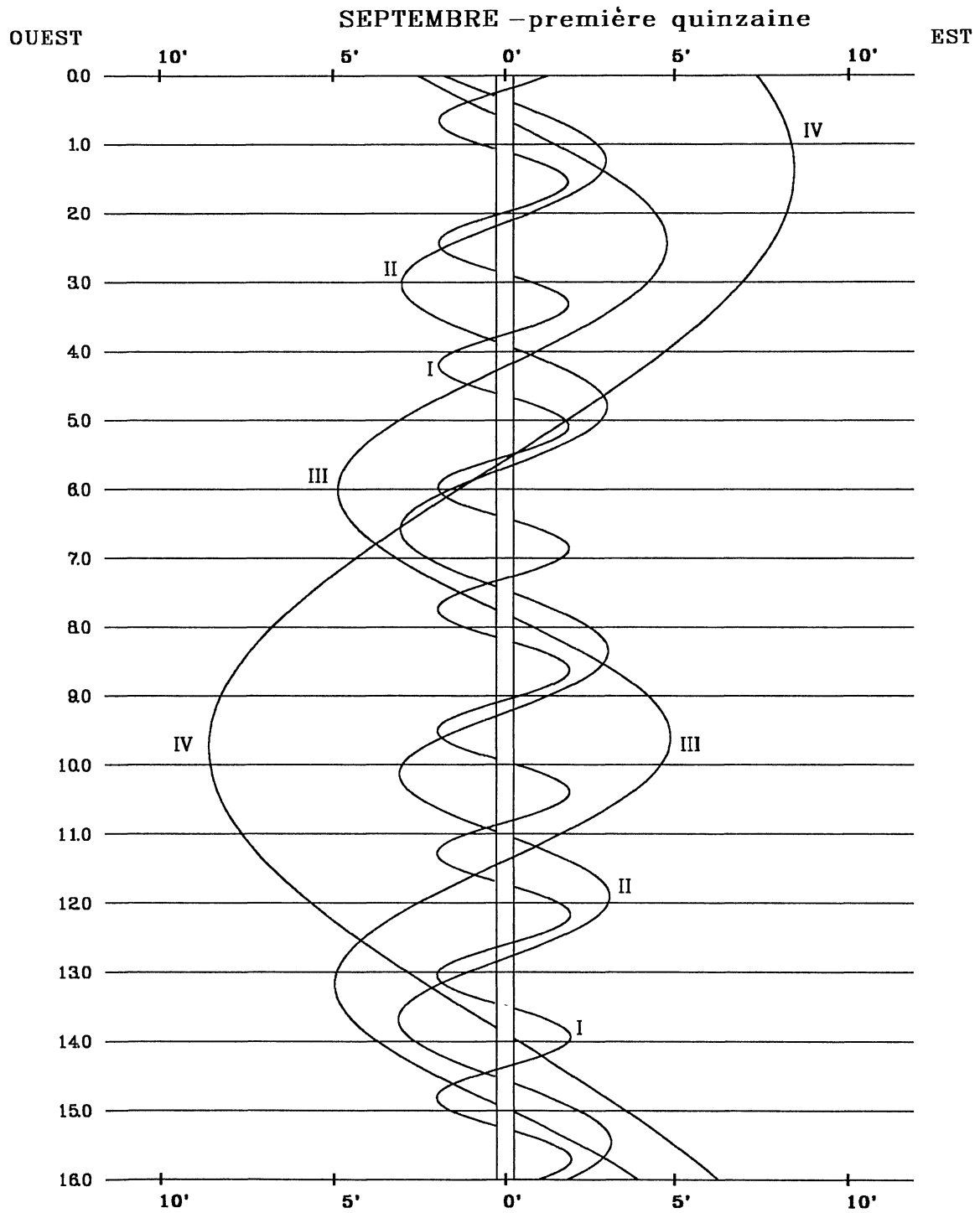

Dans le sens OUEST-EST, les satellites passent au-delà de Jupiter

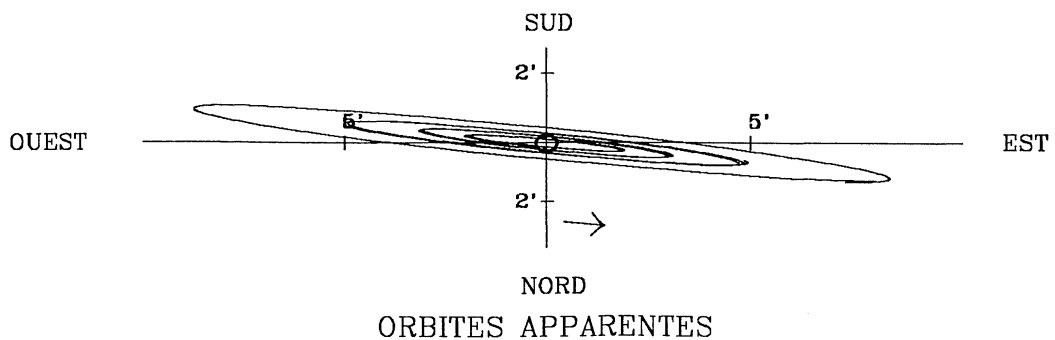

2012 - PHÉNOMÈNES DES SATELLITES GALILÉENS DE JUPITER
(Temps Terrestre)

SEPTEMBRE - DEUXIÈME QUINZAINÉ																			
jour	h	m	s	SAT.	TYPE	jour	h	m	s	SAT.	TYPE	jour	h	m	s	SAT.	TYPE		
16	0	57	56	I	OM.D.EXT	9	44	57	I	PA.D.INT	18	36	10	I	EC.D.PEN				
	1	1	42	I	OM.D.INT		10	32	28	I		OM.F.INT	18	36	58	I	EC.D.EXT		
	2	17	26	I	PA.D.EXT		10	36	15	I		OM.F.EXT	18	40	47	I	EC.D.INT		
	2	21	13	I	PA.D.INT		11	49	43	I		PA.F.INT	22	5	39	I	OC.F.INT		
	3	7	20	I	OM.F.INT		11	53	30	I		PA.F.EXT	22	9	27	I	OC.F.EXT		
	3	11	7	I	OM.F.EXT		12	5	42	II		EC.D.PEN	26	15	48	2	I	OM.D.EXT	
	4	25	57	I	PA.F.INT		12	7	30	II		EC.D.EXT		15	51	48	I	OM.D.INT	
	4	27	15	II	OM.D.EXT		12	12	12	II		EC.D.INT		17	4	20	I	PA.D.EXT	
	4	29	44	I	PA.F.EXT		14	28	49	II		EC.F.INT		17	8	7	I	PA.D.INT	
	4	31	59	II	OM.D.INT		14	33	31	II		EC.F.EXT		17	8	7	I	PA.D.INT	
	6	51	37	II	OM.F.INT		14	35	20	II		EC.F.PEN		17	57	40	I	OM.F.INT	
	6	56	23	II	OM.F.EXT		14	44	55	II		OC.D.EXT		18	1	26	I	OM.F.EXT	
	7	12	45	II	PA.D.EXT		14	49	40	II		OC.D.INT		19	12	57	I	PA.F.INT	
	7	17	36	II	PA.D.INT		17	5	53	II		OC.F.INT		19	16	43	I	PA.F.EXT	
	9	32	58	II	PA.F.INT		17	10	38	II		OC.F.EXT		20	21	50	II	OM.D.EXT	
	9	37	48	II	PA.F.EXT		20	23	34	III		EC.D.PEN		20	26	34	II	OM.D.INT	
	22	13	36	I	EC.D.PEN		20	29	1	III		EC.D.EXT		22	46	24	II	OM.F.INT	
22	14	24	I	EC.D.EXT	20	45	40	III	EC.D.INT	22	51	9		II	OM.F.EXT				
22	18	13	I	EC.D.INT	22	20	6	III	EC.F.INT	23	0	13		II	PA.D.EXT				
17	1	46	3	I	OC.F.INT	22	26	46	III	EC.F.EXT	23	5		5	II	PA.D.INT			
	1	49	52	I	OC.F.EXT	22	42	13	III	EC.F.PEN	27	1		20	13	II	PA.F.INT		
	19	26	16	I	OM.D.EXT	22	1	50	44	III		OC.D.EXT		1	25	3	II	PA.F.EXT	
	19	30	3	I	OM.D.INT	2	7	36	III	OC.D.INT		13	4	45	I	EC.D.PEN			
	20	45	24	I	PA.D.EXT	3	41	49	III	OC.F.INT		13	5	33	I	EC.D.EXT			
	20	49	11	I	PA.D.INT	3	58	41	III	OC.F.EXT		13	9	22	I	EC.D.INT			
	21	35	42	I	OM.F.INT	5	39	7	I	EC.D.PEN		16	33	25	I	OC.F.INT			
	21	39	29	I	OM.F.EXT	5	39	55	I	EC.D.EXT		16	37	13	I	OC.F.EXT			
	22	48	40	II	EC.D.PEN	5	43	44	I	EC.D.INT		28	10	16	23	I	OM.D.EXT		
	22	50	28	II	EC.D.EXT	9	10	0	I	OC.F.INT			10	20	9	I	OM.D.INT		
	22	53	56	I	PA.F.INT	9	13	49	I	OC.F.EXT			11	31	54	I	PA.D.EXT		
	22	55	10	II	EC.D.INT	23	2	51	21	I			OM.D.EXT	11	35	41	I	PA.D.INT	
	22	57	42	I	PA.F.EXT		2	55	7	I			OM.D.INT	12	26	3	I	OM.F.INT	
	18	1	11	44	II		EC.F.INT	4	8	59			I	PA.D.EXT	12	29	50	I	OM.F.EXT
		1	16	25	II		EC.F.EXT	4	12	46			I	PA.D.INT	13	40	32	I	PA.F.INT
		1	18	14	II		EC.F.PEN	5	0	53			I	OM.F.INT	13	44	19	I	PA.F.EXT
		1	29	46	II		OC.D.EXT	5	4	40			I	OM.F.EXT	14	39	53	II	EC.D.PEN
1		34	31	II	OC.D.INT		6	17	33	I			PA.F.INT	14	41	41	II	EC.D.EXT	
3		50	48	II	OC.F.INT		6	21	20	I	PA.F.EXT		14	46	23	II	EC.D.INT		
3		55	33	II	OC.F.EXT		7	3	56	II	OM.D.EXT		17	3	9	II	EC.F.INT		
6		33	31	III	OM.D.EXT		7	8	40	II	OM.D.INT		17	7	51	II	EC.F.EXT		
6		48	40	III	OM.D.INT		9	28	25	II	OM.F.INT		17	9	39	II	EC.F.PEN		
8		34	28	III	OM.F.INT		9	33	11	II	OM.F.EXT		17	13	39	II	OC.D.EXT		
8		49	53	III	OM.F.EXT		9	45	14	II	PA.D.EXT		17	18	25	II	OC.D.INT		
12		1	58	III	PA.D.EXT		9	50	6	II	PA.D.INT		19	34	29	II	OC.F.INT		
12		18	46	III	PA.D.INT		12	5	17	II	PA.F.INT	19	39	15	II	OC.F.EXT			
13		51	41	III	PA.F.INT		12	10	7	II	PA.F.EXT	29	0	22	53	III	EC.D.PEN		
14		8	15	III	PA.F.EXT		24	0	7	41	I		EC.D.PEN	0	28	18	III	EC.D.EXT	
16		42	5	I	EC.D.PEN	0		8	29	I	EC.D.EXT		0	44	49	III	EC.D.INT		
16		42	53	I	EC.D.EXT	0		12	18	I	EC.D.INT		2	20	18	III	EC.F.INT		
16	46	42	I	EC.D.INT	3	37		54	I	OC.F.INT	2		36	50	III	EC.F.EXT			
20	14	5	I	OC.F.INT	3	41		43	I	OC.F.EXT	2		42	15	III	EC.F.PEN			
20	17	54	I	OC.F.EXT	21	19		41	I	OM.D.EXT	5		38	27	III	OC.D.EXT			
19	13	54	37	I	OM.D.EXT	21		23	27	I	OM.D.INT		5	55	24	III	OC.D.INT		
	13	58	24	I	OM.D.INT	22		36	41	I	PA.D.EXT		7	28	55	III	OC.F.INT		
	15	13	19	I	PA.D.EXT	22		40	28	I	PA.D.INT		7	33	12	I	EC.D.PEN		
	15	17	7	I	PA.D.INT	23		29	16	I	OM.F.INT		7	34	1	I	EC.D.EXT		
	16	4	5	I	OM.F.INT	23		33	3	I	OM.F.EXT		7	37	49	I	EC.D.INT		
	16	7	52	I	OM.F.EXT	25		0	45	16	I		PA.F.INT	7	45	52	III	OC.F.EXT	
	17	21	52	I	PA.F.INT			0	49	3	I		PA.F.EXT	11	1	0	I	OC.F.INT	
	17	25	39	I	PA.F.EXT			0	22	49	II		EC.D.PEN	11	4	48	I	OC.F.EXT	
	17	45	11	II	OM.D.EXT			1	24	37	II		EC.D.EXT	30	4	44	46	I	OM.D.EXT
	17	49	55	II	OM.D.INT			1	29	19	II		EC.D.INT		4	48	32	I	OM.D.INT
	20	9	37	II	OM.F.INT			3	46	1	II	EC.F.INT	5		59	27	I	PA.D.EXT	
	20	14	23	II	OM.F.EXT		3	50	43	II	EC.F.EXT	6	3		14	I	PA.D.INT		
	20	28	55	II	PA.D.EXT		3	52	31	II	EC.F.PEN	6	54		29	I	OM.F.INT		
	20	33	46	II	PA.D.INT		3	59	35	II	OC.D.EXT	6	58		16	I	OM.F.EXT		
	22	49	3	II	PA.F.INT		4	4	21	II	OC.D.INT	8	8		6	I	PA.F.INT		
	22	53	53	II	PA.F.EXT		6	20	29	II	OC.F.INT	8	11		53	I	PA.F.EXT		
	20	11	10	40	I		EC.D.PEN	6	25	14	II	OC.F.EXT	9		40	32	II	OM.D.EXT	
11		11	28	I	EC.D.EXT		10	32	54	III	OM.D.EXT	9	45		15	II	OM.D.INT		
11		15	17	I	EC.D.INT		10	47	58	III	OM.D.INT	12	5		10	II	OM.F.INT		
14		42	8	I	OC.F.INT		12	34	45	III	OM.F.INT	12	9		55	II	OM.F.EXT		
14		45	57	I	OC.F.EXT		12	50	3	III	OM.F.EXT	12	15		20	II	PA.D.EXT		
21		8	22	58	I		OM.D.EXT	15	52	12	III	PA.D.EXT	12		20	11	II	PA.D.INT	
		8	26	44	I	OM.D.INT	16	9	5	III	PA.D.INT	14	35		15	II	PA.F.INT		
	9	41	10	I	PA.D.EXT	17	41	22	III	PA.F.INT	14	40	5		II	PA.F.EXT			

2012 - CONFIGURATIONS DES SATELLITES GALILÉENS DE JUPITER

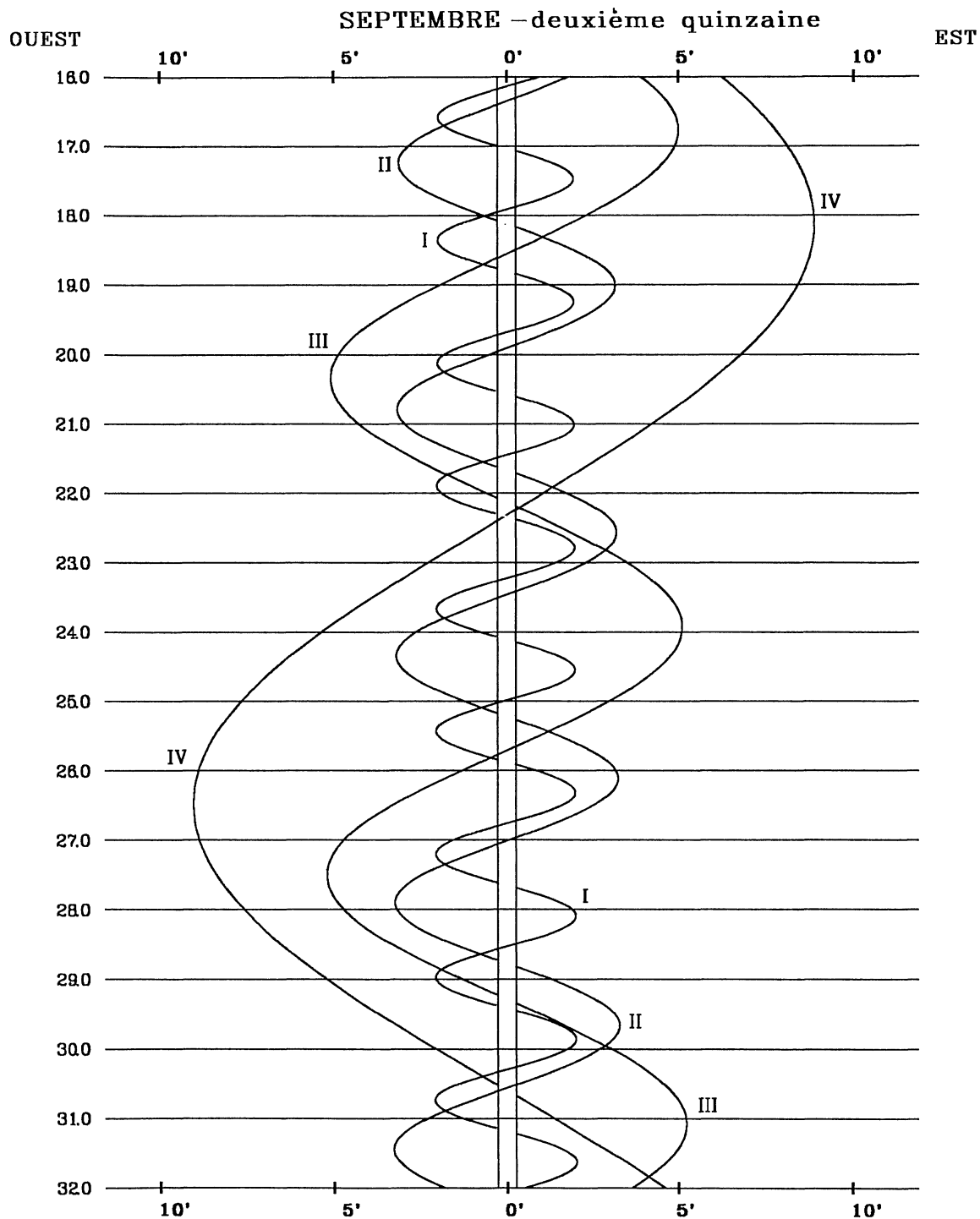

Dans le sens OUEST-EST, les satellites passent au-delà de Jupiter

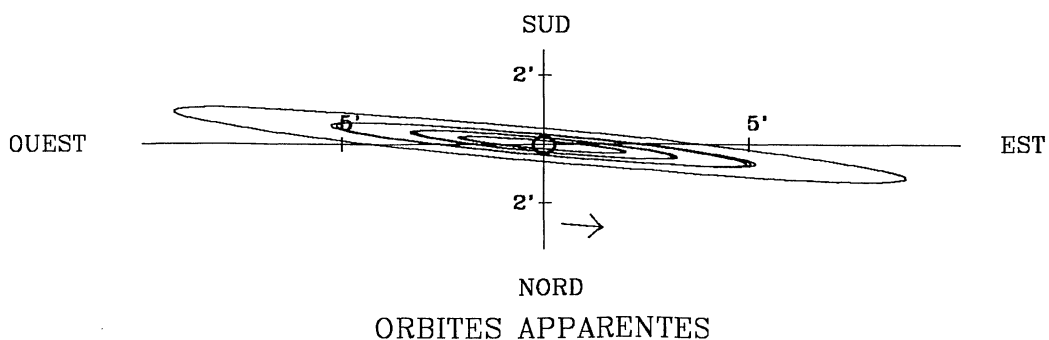

2012 - PHÉNOMÈNES DES SATELLITES GALILÉENS DE JUPITER
(Temps Terrestre)

OCTOBRE - PREMIÈRE QUINZAINE																	
jour	h	m	s	SAT.	TYPE	jour	h	m	s	SAT.	TYPE	jour	h	m	s	SAT.	TYPE
1	2	1	46	I	EC.D.PEN	19	42	18	II	EC.F.EXT	20	43	3	I	PA.D.EXT		
	2	2	34	I	EC.D.EXT		19	44	7	II		EC.F.PEN	20	46	50	I	PA.D.INT
	2	6	23	I	EC.D.INT		19	44	56	II		OC.D.INT	21	44	59	I	OM.F.INT
	5	28	35	I	OC.F.INT		22	0	52	II		OC.F.INT	21	48	46	I	OM.F.EXT
	5	32	24	I	OC.F.EXT		22	5	39	II		OC.F.EXT	22	51	54	I	PA.F.INT
	23	13	7	I	OM.D.EXT								22	55	41	I	PA.F.EXT
2	23	16	53	I	OM.D.INT	6	4	22	20	III	EC.D.PEN	11	1	34	52	II	OM.D.EXT
	0	26	52	I	PA.D.EXT		4	27	43	III	EC.D.EXT		1	39	35	II	OM.D.INT
0	30	39	I	PA.D.INT	4		44	6	III	EC.D.INT	3		55	32	II	PA.D.EXT	
1	22	53	I	OM.F.INT	6		20	42	III	EC.F.INT	3		59	49	II	OM.F.INT	
1	26	39	I	OM.F.EXT	6		37	4	III	EC.F.EXT	4		0	23	II	PA.D.INT	
2	35	33	I	PA.F.INT	6		42	27	III	EC.F.PEN	4		4	34	II	OM.F.EXT	
2	39	20	I	PA.F.EXT	9	21	29	III	OC.D.EXT	6	15	22	II	PA.F.INT			
3	57	2	II	EC.D.PEN	9	27	18	I	EC.D.PEN	6	20	12	II	PA.F.EXT			
3	58	51	II	EC.D.EXT	9	28	6	I	EC.D.EXT	16	52	57	I	EC.D.PEN			
4	3	32	II	EC.D.INT	9	31	55	I	EC.D.INT	16	53	45	I	EC.D.EXT			
6	20	23	II	EC.F.INT	9	38	31	III	OC.D.INT	16	57	33	I	EC.D.INT			
6	25	5	II	EC.F.EXT	11	11	21	III	OC.F.INT	20	12	28	I	OC.F.INT			
6	26	53	II	EC.F.PEN	11	28	23	III	OC.F.EXT	20	16	16	I	OC.F.EXT			
6	27	12	II	OC.D.EXT	12	50	49	I	OC.F.INT	12	14	3	18	I	OM.D.EXT		
6	31	58	II	OC.D.INT	12	54	37	I	OC.F.EXT		14	7	4	I	OM.D.INT		
8	47	57	II	OC.F.INT	7	6	38	13	I		OM.D.EXT	15	10	3	I	PA.D.EXT	
8	52	44	II	OC.F.EXT		6	41	59	I		OM.D.INT	15	13	51	I	PA.D.INT	
14	32	51	III	OM.D.EXT		7	48	48	I		PA.D.EXT	16	13	24	I	OM.F.INT	
14	47	49	III	OM.D.INT		7	52	36	I		PA.D.INT	16	17	11	I	OM.F.EXT	
16	35	39	III	OM.F.INT		8	48	9	I	OM.F.INT	17	18	56	I	PA.F.INT		
16	50	50	III	OM.F.EXT		8	51	55	I	OM.F.EXT	17	22	43	I	PA.F.EXT		
19	38	12	III	PA.D.EXT	9	57	35	I	PA.F.INT	19	48	41	II	EC.D.PEN			
19	55	9	III	PA.D.INT	10	1	22	I	PA.F.EXT	19	50	29	II	EC.D.EXT			
20	30	15	I	EC.D.PEN	12	17	1	II	OM.D.EXT	19	55	11	II	EC.D.INT			
20	31	4	I	EC.D.EXT	12	21	44	II	OM.D.INT	13	0	25	6	II	OC.F.INT		
20	34	52	I	EC.D.INT	14	41	50	II	OM.F.INT		0	29	54	II	OC.F.EXT		
21	26	52	III	PA.F.INT	14	42	57	II	PA.D.EXT		8	22	38	III	EC.D.PEN		
21	43	37	III	PA.F.EXT	14	46	35	II	OM.F.EXT		8	27	59	III	EC.D.EXT		
23	56	3	I	OC.F.INT	14	47	49	II	PA.D.INT		8	44	13	III	EC.D.INT		
23	59	52	I	OC.F.EXT	17	2	48	II	PA.F.INT		10	21	56	III	EC.F.INT		
3	17	41	28	I	OM.D.EXT	17	7	38	II	PA.F.EXT	10	38	10	III	EC.F.EXT		
	17	45	15	I	OM.D.INT	8	3	55	52	I	EC.D.PEN	10	43	31	III	EC.F.PEN	
	18	54	15	I	PA.D.EXT		3	56	40	I	EC.D.EXT	11	21	26	I	EC.D.PEN	
	18	58	2	I	PA.D.INT		4	0	29	I	EC.D.INT	11	22	14	I	EC.D.EXT	
	19	51	18	I	OM.F.INT		7	18	7	I	OC.F.INT	11	26	2	I	EC.D.INT	
	19	55	4	I	OM.F.EXT		7	21	56	I	OC.F.EXT	13	0	26	III	OC.D.EXT	
	21	2	58	I	PA.F.INT		9	1	6	34	I	OM.D.EXT	13	17	33	III	OC.D.INT
	21	6	45	I	PA.F.EXT	1		10	20	I	OM.D.INT	14	39	28	I	OC.F.INT	
	22	58	25	II	OM.D.EXT	2		15	57	I	PA.D.EXT	14	43	17	I	OC.F.EXT	
	23	3	9	II	OM.D.INT	2		19	44	I	PA.D.INT	14	49	44	III	OC.F.INT	
4	1	23	10	II	OM.F.INT	3		16	33	I	OM.F.INT	15	6	51	III	OC.F.EXT	
	1	27	55	II	OM.F.EXT	3		20	20	I	OM.F.EXT	14	8	31	43	I	OM.D.EXT
	1	29	9	II	PA.D.EXT	4	24	46	I	PA.F.INT	8		35	29	I	OM.D.INT	
	1	34	0	II	PA.D.INT	4	28	33	I	PA.F.EXT	9		37	3	I	PA.D.EXT	
	3	49	2	II	PA.F.INT	6	31	26	II	EC.D.PEN	9		40	50	I	PA.D.INT	
	3	53	52	II	PA.F.EXT	6	33	14	II	EC.D.EXT	10		41	53	I	OM.F.INT	
	14	58	50	I	EC.D.PEN	6	37	56	II	EC.D.INT	10		45	40	I	OM.F.EXT	
	14	59	38	I	EC.D.EXT	11	13	15	II	OC.F.INT	11	45	58	I	PA.F.INT		
	15	3	27	I	EC.D.INT	11	18	2	II	OC.F.EXT	11	49	45	I	PA.F.EXT		
	18	23	31	I	OC.F.INT	18	31	54	III	OM.D.EXT	14	53	23	II	OM.D.EXT		
18	27	20	I	OC.F.EXT	18	46	47	III	OM.D.INT	14	58	6	II	OM.D.INT			
5	12	9	49	I	OM.D.EXT	20	35	43	III	OM.F.INT	17	8	4	II	PA.D.EXT		
	12	13	36	I	OM.D.INT	20	50	47	III	OM.F.EXT	17	12	56	II	PA.D.INT		
	13	21	32	I	PA.D.EXT	22	24	22	I	EC.D.PEN	17	18	26	II	OM.F.INT		
	13	25	19	I	PA.D.INT	22	25	10	I	EC.D.EXT	17	23	10	II	OM.F.EXT		
	14	19	42	I	OM.F.INT	22	28	58	I	EC.D.INT	19	27	53	II	PA.F.INT		
	14	23	28	I	OM.F.EXT	23	18	33	III	PA.D.EXT	19	32	43	II	PA.F.EXT		
	15	30	17	I	PA.F.INT	23	35	34	III	PA.D.INT	15	5	50	0	I	EC.D.PEN	
	15	34	4	I	PA.F.EXT	10	1	6	43	III		PA.F.INT	5	50	48	I	EC.D.EXT
	17	14	11	II	EC.D.PEN		1	23	34	III		PA.F.EXT	5	54	36	I	EC.D.INT
	17	15	59	II	EC.D.EXT		1	45	17	I		OC.F.INT	9	6	29	I	OC.F.INT
17	20	41	II	EC.D.INT	1		49	6	I	OC.F.EXT		9	10	17	I	OC.F.EXT	
19	37	36	II	EC.F.INT	19		34	56	I	OM.D.EXT							
19	40	10	II	OC.D.EXT	19		38	43	I	OM.D.INT							

2012 - CONFIGURATIONS DES SATELLITES GALILÉENS DE JUPITER

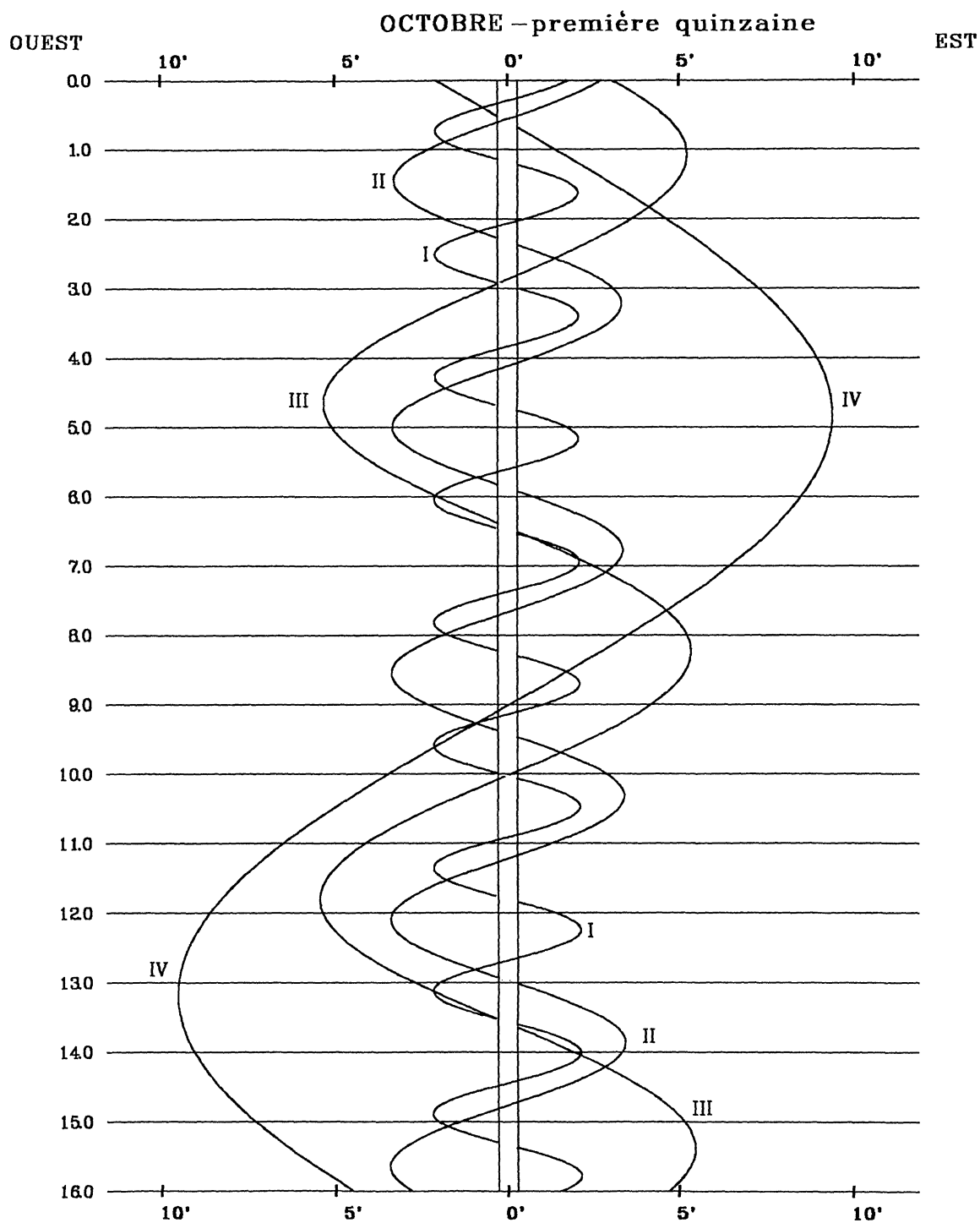

Dans le sens OUEST-EST, les satellites passent au-delà de Jupiter

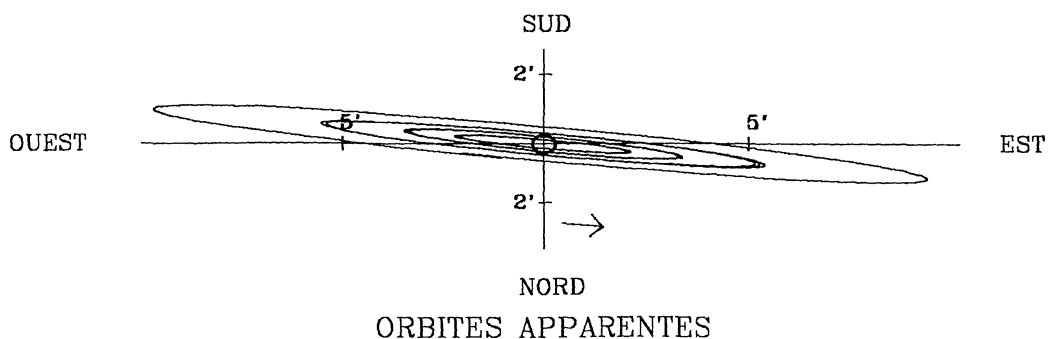

2012 - PHÉNOMÈNES DES SATELLITES GALILÉENS DE JUPITER
(Temps Terrestre)

OCTOBRE - DEUXIÈME QUINZAINE																	
jour	h	m	s	SAT.	TYPE	jour	h	m	s	SAT.	TYPE	jour	h	m	s	SAT.	TYPE
16	3	0	5	I	OM.D.EXT		18	39	57	III	OC.F.EXT		18	47	39	I	PA.D.INT
	3	3	51	I	OM.D.INT								20	1	7	I	OM.F.INT
	4	3	55	I	PA.D.EXT	21	10	25	17	I	OM.D.EXT		20	4	53	I	OM.F.EXT
	4	7	42	I	PA.D.INT		10	29	3	I	OM.D.INT		20	53	4	I	PA.F.INT
	5	10	19	I	OM.F.INT		11	24	12	I	PA.D.EXT		20	56	52	I	PA.F.EXT
	5	14	5	I	OM.F.EXT		11	28	0	I	PA.D.INT						
	6	12	53	I	PA.F.INT		12	35	43	I	OM.F.INT	27	0	58	12	II	EC.D.PEN
	6	16	40	I	PA.F.EXT		12	39	29	I	OM.F.EXT		1	0	0	II	EC.D.EXT
	9	5	58	II	EC.D.PEN		13	33	17	I	PA.F.INT		1	4	42	II	EC.D.INT
	9	7	47	II	EC.D.EXT		13	37	5	I	PA.F.EXT		5	7	3	II	OC.F.INT
	9	12	28	II	EC.D.INT		17	29	43	II	OM.D.EXT		5	11	51	II	OC.F.EXT
	13	36	20	II	OC.F.INT		17	34	26	II	OM.D.INT		15	9	47	I	EC.D.PEN
	13	41	7	II	OC.F.EXT		19	30	46	II	PA.D.EXT		15	10	35	I	EC.D.EXT
	22	30	47	III	OM.D.EXT		19	35	38	II	PA.D.INT		15	14	23	I	EC.D.INT
	22	45	34	III	OM.D.INT		19	55	1	II	OM.F.INT		16	22	48	III	EC.D.PEN
							19	59	44	II	OM.F.EXT		16	28	4	III	EC.D.EXT
							21	50	36	II	PA.F.INT		16	43	59	III	EC.D.INT
17	0	18	30	I	EC.D.PEN		21	55	26	II	PA.F.EXT		18	13	24	I	OC.F.INT
	0	19	18	I	EC.D.EXT								18	17	12	I	OC.F.EXT
	0	23	6	I	EC.D.INT								18	24	7	III	EC.F.INT
	0	35	39	III	OM.F.INT	22	7	44	10	I	EC.D.PEN		18	40	2	III	EC.F.EXT
	0	50	36	III	OM.F.EXT		7	44	57	I	EC.D.EXT		18	45	19	III	EC.F.PEN
	2	53	48	III	PA.D.EXT		7	48	45	I	EC.D.INT		20	3	4	III	OC.D.EXT
	3	10	54	III	PA.D.INT		10	53	42	I	OC.F.INT		20	20	15	III	OC.D.INT
	3	33	21	I	OC.F.INT		10	57	30	I	OC.F.EXT		21	51	43	III	OC.F.INT
	3	37	10	I	OC.F.EXT								22	8	54	III	OC.F.EXT
	4	41	35	III	PA.F.INT	23	4	53	40	I	OM.D.EXT						
	4	58	32	III	PA.F.EXT		4	57	26	I	OM.D.INT						
	21	28	28	I	OM.D.EXT		5	50	48	I	PA.D.EXT	28	12	18	56	I	OM.D.EXT
	21	32	14	I	OM.D.INT		5	54	36	I	PA.D.INT		12	22	43	I	OM.D.INT
	22	30	44	I	PA.D.EXT		7	4	10	I	OM.F.INT		13	10	20	I	PA.D.EXT
	22	34	32	I	PA.D.INT		7	7	56	I	OM.F.EXT		13	14	7	I	PA.D.INT
	23	38	46	I	OM.F.INT		7	59	56	I	PA.F.INT		14	29	39	I	OM.F.INT
	23	42	33	I	OM.F.EXT		8	3	43	I	PA.F.EXT		14	33	26	I	OM.F.EXT
							11	40	42	II	EC.D.PEN		15	19	36	I	PA.F.INT
18	0	39	45	I	PA.F.INT		11	42	30	II	EC.D.EXT		15	23	23	I	PA.F.EXT
	0	43	32	I	PA.F.EXT		11	47	12	II	EC.D.INT		20	5	57	II	OM.D.EXT
	4	11	16	II	OM.D.EXT		15	57	15	II	OC.F.INT		20	10	39	II	OM.D.INT
	4	15	58	II	OM.D.INT		16	2	3	II	OC.F.EXT		21	51	7	II	PA.D.EXT
	6	19	27	II	PA.D.EXT								21	55	58	II	PA.D.INT
	6	24	19	II	PA.D.INT	24	2	12	40	I	EC.D.PEN		22	31	30	II	OM.F.INT
	6	36	26	II	OM.F.INT		2	13	28	I	EC.D.EXT		22	36	13	II	OM.F.EXT
	6	41	10	II	OM.F.EXT		2	17	16	I	EC.D.INT						
	8	39	17	II	PA.F.INT		2	29	42	III	OM.D.EXT	29	0	11	2	II	PA.F.INT
	8	44	7	II	PA.F.EXT		2	44	25	III	OM.D.INT		0	15	52	II	PA.F.EXT
	18	47	6	I	EC.D.PEN		4	35	38	III	OM.F.INT		9	38	22	I	EC.D.PEN
	18	47	54	I	EC.D.EXT		4	50	29	III	OM.F.EXT		9	39	10	I	EC.D.EXT
	18	51	42	I	EC.D.INT		5	20	18	I	OC.F.INT		9	42	58	I	EC.D.INT
	22	0	15	I	OC.F.INT		5	24	7	I	OC.F.EXT		12	39	52	I	OC.F.INT
	22	4	3	I	OC.F.EXT		6	24	25	III	PA.D.EXT		12	43	41	I	OC.F.EXT
							6	41	34	III	PA.D.INT						
19	15	56	51	I	OM.D.EXT		8	11	53	III	PA.F.INT	30	6	47	21	I	OM.D.EXT
	16	0	37	I	OM.D.INT		8	28	56	III	PA.F.EXT		6	51	7	I	OM.D.INT
	16	57	28	I	PA.D.EXT		23	22	5	I	OM.D.EXT		7	36	41	I	PA.D.EXT
	17	1	16	I	PA.D.INT		23	25	51	I	OM.D.INT		7	40	29	I	PA.D.INT
	18	7	13	I	OM.F.INT								8	58	8	I	OM.F.INT
	18	10	59	I	OM.F.EXT	25	0	17	22	I	PA.D.EXT		9	1	54	I	OM.F.EXT
	19	6	31	I	PA.F.INT		0	21	10	I	PA.D.INT		9	46	0	I	PA.F.INT
	19	10	18	I	PA.F.EXT		1	32	39	I	OM.F.INT		9	49	48	I	PA.F.EXT
	22	23	19	II	EC.D.PEN		1	36	26	I	OM.F.EXT		14	15	40	II	EC.D.PEN
	22	25	8	II	EC.D.EXT		2	26	33	I	PA.F.INT		14	17	29	II	EC.D.EXT
	22	29	49	II	EC.D.INT		2	30	21	I	PA.F.EXT		14	22	11	II	EC.D.INT
							6	47	33	II	OM.D.EXT		18	16	13	II	OC.F.INT
20	2	47	6	II	OC.F.INT		6	52	15	II	OM.D.INT		18	21	2	II	OC.F.EXT
	2	51	54	II	OC.F.EXT		8	40	58	II	PA.D.EXT						
	12	22	28	III	EC.D.PEN		8	45	49	II	PA.D.INT	31	4	6	54	I	EC.D.PEN
	12	27	47	III	EC.D.EXT		9	12	59	II	OM.F.INT		4	7	42	I	EC.D.EXT
	12	43	52	III	EC.D.INT		9	17	42	II	OM.F.EXT		4	11	30	I	EC.D.INT
	13	15	35	I	EC.D.PEN		11	0	50	II	PA.F.INT		6	28	53	III	OM.D.EXT
	13	16	23	I	EC.D.EXT		11	5	41	II	PA.F.EXT		6	43	31	III	OM.D.INT
	13	20	11	I	EC.D.INT		20	41	17	I	EC.D.PEN		7	6	14	I	OC.F.INT
	14	22	45	III	EC.F.INT		20	42	5	I	EC.D.EXT		7	10	2	I	OC.F.EXT
	14	38	50	III	EC.F.EXT		20	45	53	I	EC.D.INT		8	35	54	III	OM.F.INT
	14	44	9	III	EC.F.PEN		23	46	56	I	OC.F.INT		8	50	39	III	OM.F.EXT
	16	26	58	I	OC.F.INT		23	50	44	I	OC.F.EXT		9	50	43	III	PA.D.EXT
	16	30	47	I	OC.F.EXT								10	7	54	III	PA.D.INT
	16	33	54	III	OC.D.EXT	26	17	50	29	I	OM.D.EXT		11	38	5	III	PA.F.INT
	16	51	4	III	OC.D.INT		17	54	15	I	OM.D.INT		11	55	11	III	PA.F.EXT
	18	22	47	III	OC.F.INT		18	43	51	I	PA.D.EXT						

2012 - CONFIGURATIONS DES SATELLITES GALILÉENS DE JUPITER

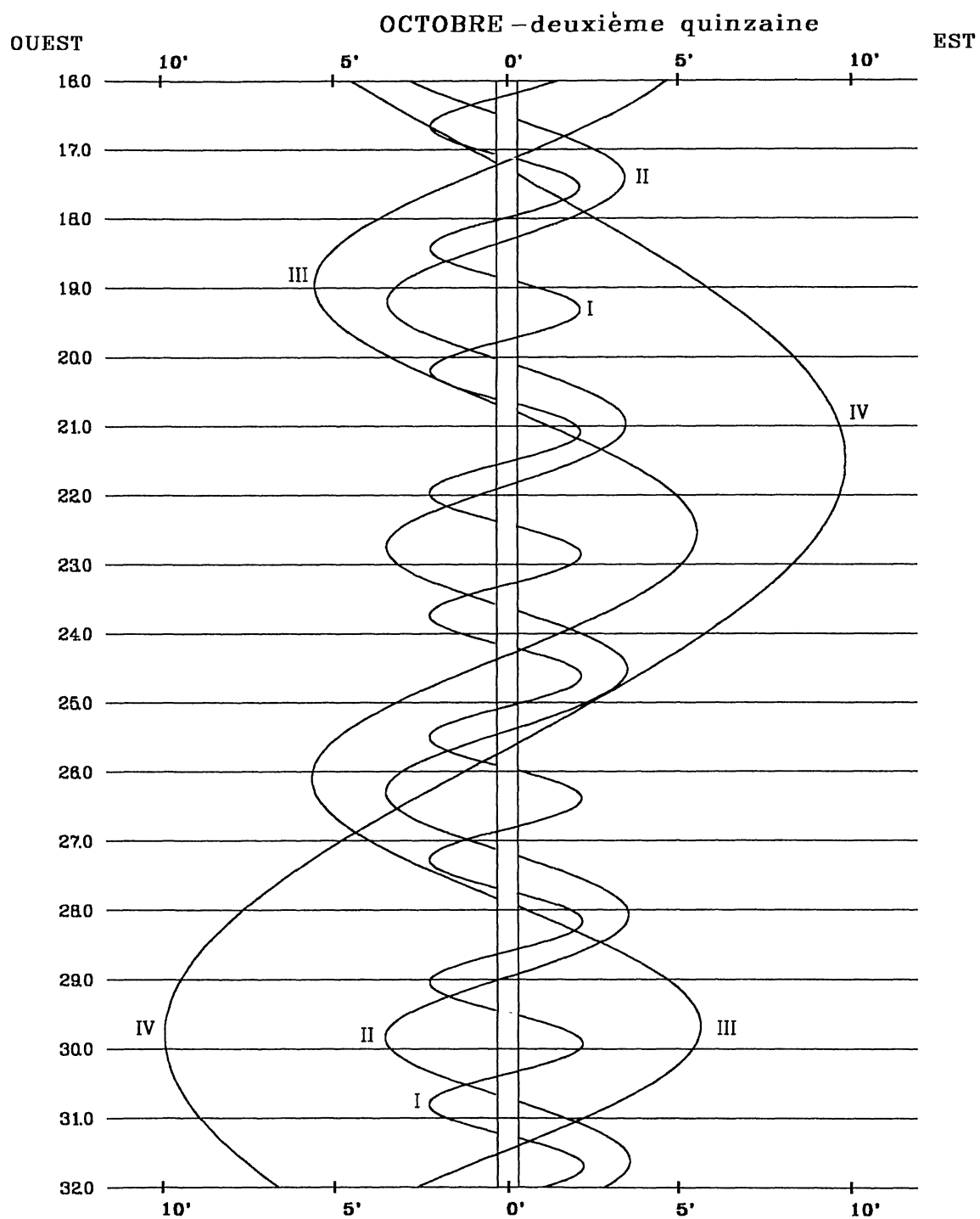

Dans le sens OUEST-EST, les satellites passent au-delà de Jupiter

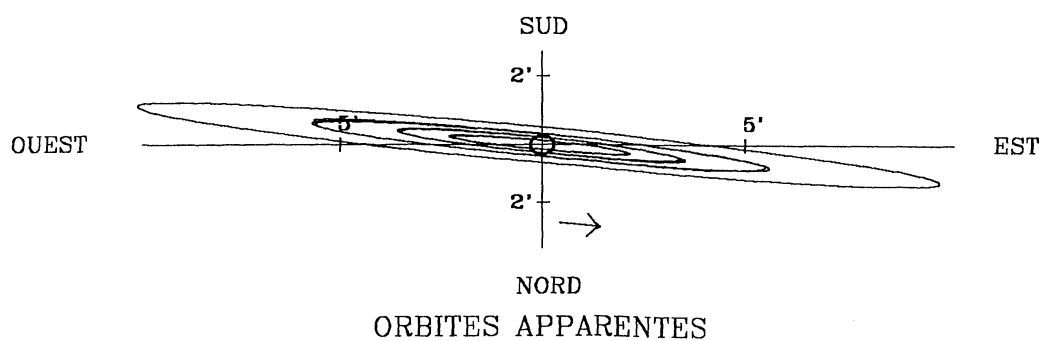

2012 - PHÉNOMÈNES DES SATELLITES GALILÉENS DE JUPITER
(Temps Terrestre)

NOVEMBRE - PREMIÈRE QUINZAINE																	
jour	h	m	s	SAT.	TYPE	jour	h	m	s	SAT.	TYPE	jour	h	m	s	SAT.	TYPE
1	1	15	48	I	OM.D.EXT							2	25	23		III	EC.F.INT
	1	19	34	I	OM.D.INT								2	40	59	III	EC.F.EXT
	2	3	2	I	PA.D.EXT	6	8	41	10	I	OM.D.EXT		2	46	11	III	EC.F.PEN
	2	6	50	I	PA.D.INT		8	44	57	I	OM.D.INT		2	47	24	III	OC.D.EXT
	3	26	39	I	OM.F.INT		9	21	42	I	PA.D.EXT		3	4	30	III	OC.D.INT
	3	30	26	I	OM.F.EXT		9	25	29	I	PA.D.INT		4	36	21	III	OC.F.INT
	4	12	23	I	PA.F.INT		10	52	13	I	OM.F.INT		4	53	27	III	OC.F.EXT
	4	16	11	I	PA.F.EXT		10	56	0	I	OM.F.EXT		16	6	40	I	OM.D.EXT
	9	23	47	II	OM.D.EXT		11	31	11	I	PA.F.INT		16	10	26	I	OM.D.INT
	9	28	29	II	OM.D.INT		11	34	59	I	PA.F.EXT		16	39	58	I	PA.D.EXT
	11	0	16	II	PA.D.EXT		16	50	50	II	EC.D.PEN		16	43	46	I	PA.D.INT
	11	5	6	II	PA.D.INT		16	52	39	II	EC.D.EXT		18	17	55	I	OM.F.INT
	11	49	28	II	OM.F.INT		16	57	21	II	EC.D.INT		18	21	41	I	OM.F.EXT
	11	54	11	II	OM.F.EXT		20	33	23	II	OC.F.INT		18	49	36	I	PA.F.INT
	13	20	14	II	PA.F.INT		20	38	12	II	OC.F.EXT		18	53	24	I	PA.F.EXT
	13	25	4	II	PA.F.EXT	7	6	1	11	I	EC.D.PEN						
	22	35	31	I	EC.D.PEN		6	1	59	I	EC.D.EXT	12	1	18	20	II	OM.D.EXT
	22	36	19	I	EC.D.EXT		6	5	47	I	EC.D.INT		1	23	1	II	OM.D.INT
	22	40	7	I	EC.D.INT		8	51	15	I	OC.F.INT		2	25	49	II	PA.D.EXT
							8	55	3	I	OC.F.EXT		2	30	39	II	PA.D.INT
2	1	32	37	I	OC.F.INT		10	28	55	III	OM.D.EXT		3	44	21	II	OM.F.INT
	1	36	26	I	OC.F.EXT		10	43	28	III	OM.D.INT		3	49	3	II	OM.F.EXT
	19	44	14	I	OM.D.EXT		12	37	3	III	OM.F.INT		4	46	2	II	PA.F.INT
	19	48	0	I	OM.D.INT		12	51	41	III	OM.F.EXT		4	50	52	II	PA.F.EXT
	20	29	17	I	PA.D.EXT		13	13	46	III	PA.D.EXT		13	26	59	I	EC.D.PEN
	20	33	4	I	PA.D.INT		13	30	56	III	PA.D.INT		13	27	47	I	EC.D.EXT
	21	55	9	I	OM.F.INT		15	1	16	III	PA.F.INT		13	31	34	I	EC.D.INT
	21	58	55	I	OM.F.EXT		15	18	23	III	PA.F.EXT		16	9	33	I	OC.F.INT
	22	38	41	I	PA.F.INT								16	13	21	I	OC.F.EXT
	22	42	28	I	PA.F.EXT	8	3	9	40	I	OM.D.EXT						
3	3	33	16	II	EC.D.PEN		3	13	26	I	OM.D.INT	13	10	35	9	I	OM.D.EXT
	3	35	5	II	EC.D.EXT		3	47	50	I	PA.D.EXT		10	38	55	I	OM.D.INT
	3	39	47	II	EC.D.INT		3	51	38	I	PA.D.INT		11	5	57	I	PA.D.EXT
	7	25	5	II	OC.F.INT		5	20	47	I	OM.F.INT		11	9	45	I	PA.D.INT
	7	29	54	II	OC.F.EXT		5	24	33	I	OM.F.EXT		12	46	27	I	OM.F.INT
	17	4	2	I	EC.D.PEN		5	57	22	I	PA.F.INT		12	50	14	I	OM.F.EXT
	17	4	50	I	EC.D.EXT		6	1	10	I	PA.F.EXT		13	15	37	I	PA.F.INT
	17	8	38	I	EC.D.INT		12	0	1	II	OM.D.EXT		13	19	25	I	PA.F.EXT
	19	58	51	I	OC.F.INT		12	4	42	II	OM.D.INT		19	26	19	II	EC.D.PEN
	20	2	40	I	OC.F.EXT		13	17	36	II	PA.D.EXT		19	28	8	II	EC.D.EXT
	20	22	24	III	EC.D.PEN		13	22	26	II	PA.D.INT		19	32	50	II	EC.D.INT
	20	27	38	III	EC.D.EXT		14	25	56	II	OM.F.INT		22	49	7	II	OC.F.INT
	20	43	24	III	EC.D.INT		14	30	38	II	OM.F.EXT		22	53	56	II	OC.F.EXT
	22	24	46	III	EC.F.INT		15	37	44	II	PA.F.INT						
	22	40	32	III	EC.F.EXT		15	42	34	II	PA.F.EXT	14	7	55	33	I	EC.D.PEN
	22	45	46	III	EC.F.PEN								7	56	21	I	EC.D.EXT
	23	27	12	III	OC.D.EXT	9	0	29	50	I	EC.D.PEN		8	0	8	I	EC.D.INT
	23	44	22	III	OC.D.INT		0	30	37	I	EC.D.EXT		10	35	32	I	OC.F.INT
							0	34	25	I	EC.D.INT		10	39	20	I	OC.F.EXT
4	1	15	51	III	OC.F.INT		3	17	26	I	OC.F.INT		14	28	39	III	OM.D.EXT
	1	33	1	III	OC.F.EXT		3	21	14	I	OC.F.EXT		14	43	7	III	OM.D.INT
	14	12	44	I	OM.D.EXT		21	38	7	I	OM.D.EXT		16	32	49	III	PA.D.EXT
	14	16	30	I	OM.D.INT		21	41	54	I	OM.D.INT		16	37	53	III	OM.F.INT
	14	55	33	I	PA.D.EXT		22	13	53	I	PA.D.EXT		16	49	56	III	PA.D.INT
	14	59	20	I	PA.D.INT		22	17	41	I	PA.D.INT		16	52	25	III	OM.F.EXT
	16	23	43	I	OM.F.INT		23	49	18	I	OM.F.INT		18	20	50	III	PA.F.INT
	16	27	29	I	OM.F.EXT		23	53	5	I	OM.F.EXT		18	37	54	III	PA.F.EXT
	17	5	0	I	PA.F.INT	10	0	23	28	I	PA.F.INT	15	5	3	41	I	OM.D.EXT
	17	8	47	I	PA.F.EXT		0	27	16	I	PA.F.EXT		5	7	27	I	OM.D.INT
	22	42	11	II	OM.D.EXT		6	8	36	II	EC.D.PEN		5	31	56	I	PA.D.EXT
	22	46	52	II	OM.D.INT		6	10	25	II	EC.D.EXT		5	35	44	I	PA.D.INT
							6	15	7	II	EC.D.INT		7	15	3	I	OM.F.INT
5	0	9	24	II	PA.D.EXT		9	41	30	II	OC.F.INT		7	18	50	I	OM.F.EXT
	0	14	15	II	PA.D.INT		9	46	19	II	OC.F.EXT		7	41	39	I	PA.F.INT
	1	7	58	II	OM.F.INT		18	58	22	I	EC.D.PEN		7	45	27	I	PA.F.EXT
	1	12	40	II	OM.F.EXT		18	59	10	I	EC.D.EXT		14	36	12	II	OM.D.EXT
	2	29	26	II	PA.F.INT		19	2	57	I	EC.D.INT		14	40	53	II	OM.D.INT
	2	34	16	II	PA.F.EXT		21	43	29	I	OC.F.INT		15	33	15	II	PA.D.EXT
	11	32	39	I	EC.D.PEN		21	47	17	I	OC.F.EXT		15	38	5	II	PA.D.INT
	11	33	26	I	EC.D.EXT								17	2	20	II	OM.F.INT
	11	37	14	I	EC.D.INT	11	0	21	56	III	EC.D.PEN		17	7	2	II	OM.F.EXT
	14	25	6	I	OC.F.INT		0	27	7	III	EC.D.EXT		17	53	36	II	PA.F.INT
	14	28	55	I	OC.F.EXT		0	42	44	III	EC.D.INT		17	58	25	II	PA.F.EXT

2012 – CONFIGURATIONS DES SATELLITES GALILÉENS DE JUPITER

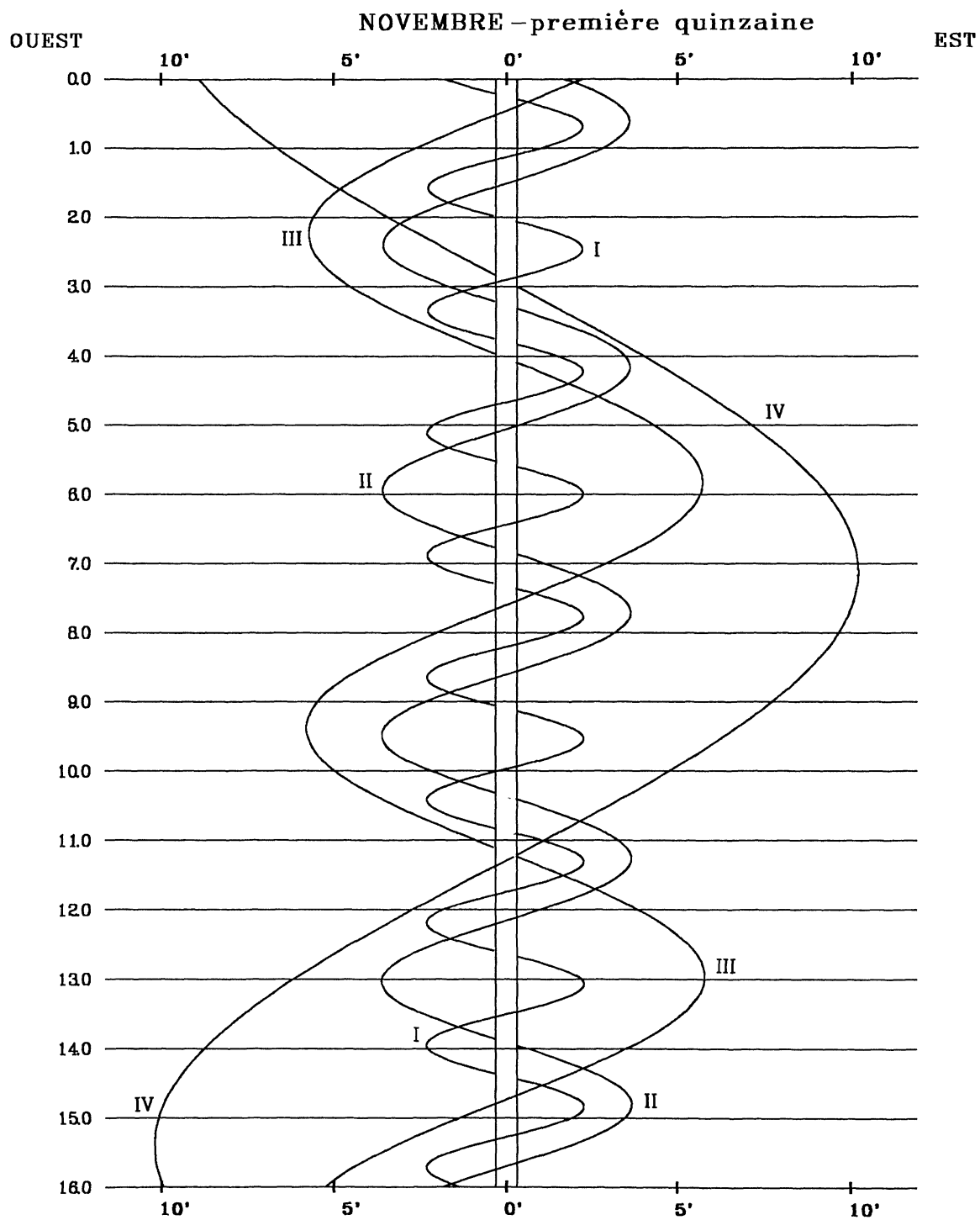

Dans le sens OUEST-EST, les satellites passent au-delà de Jupiter

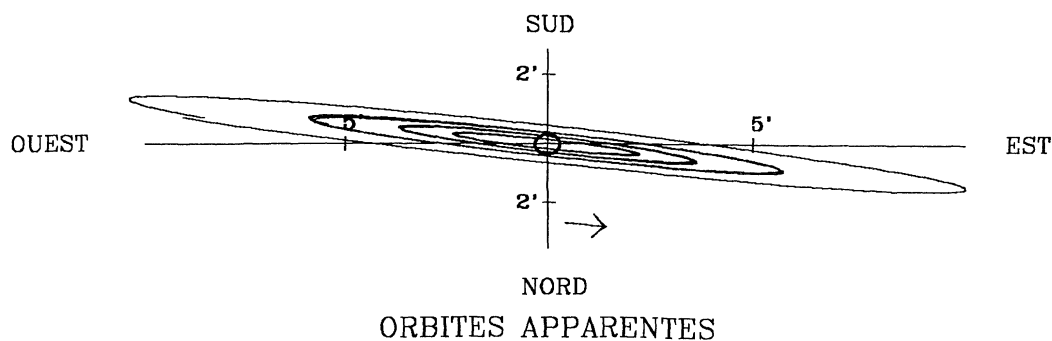

2012 – CONFIGURATIONS DES SATELLITES GALILÉENS DE JUPITER

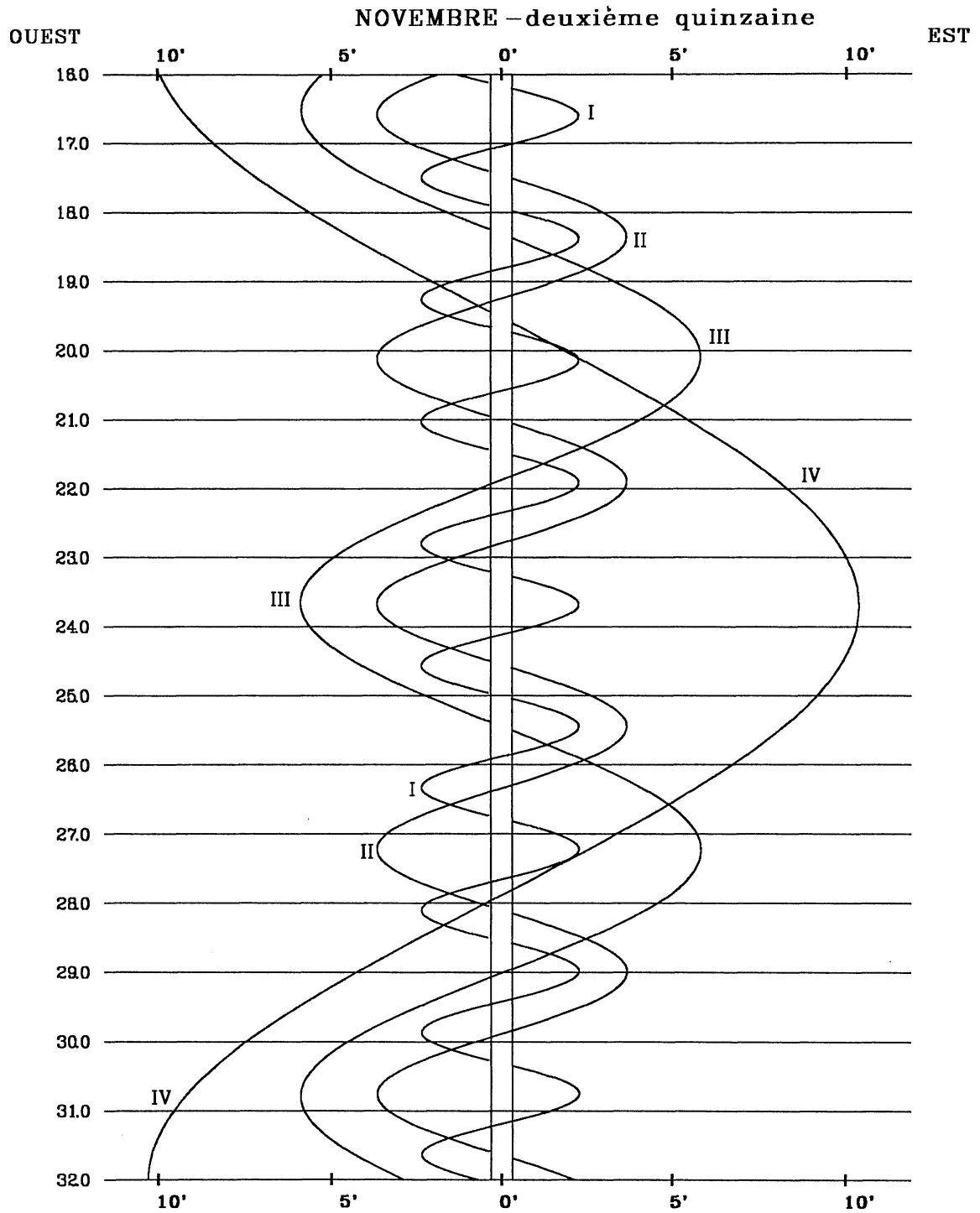

Dans le sens OUEST–EST, les satellites passent au-delà de Jupiter

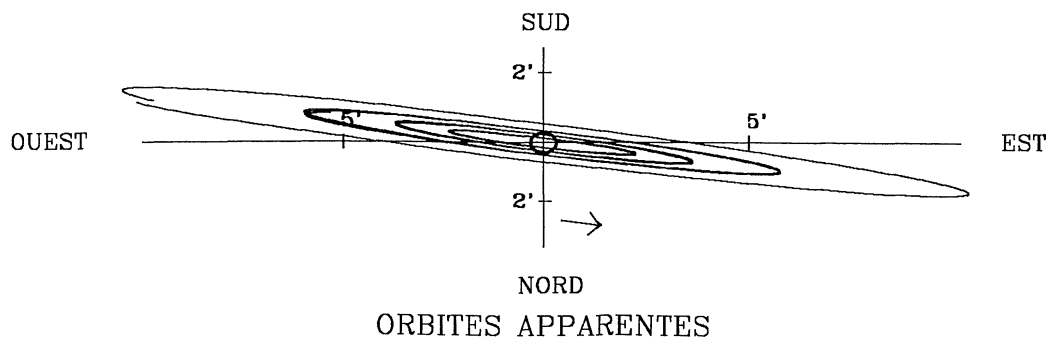

2012 - PHÉNOMÈNES DES SATELLITES GALILÉENS DE JUPITER
(Temps Terrestre)

DÉCEMBRE - PREMIÈRE QUINZAINE																				
jour	h	m	s	SAT.	TYPE	jour	h	m	s	SAT.	TYPE	jour	h	m	s	SAT.	TYPE			
1	3	20	54	I	OM.D.EXT	2	34	23	III	PA.D.INT	20	53	36	I	OC.D.EXT					
	3	24	40	I	OM.D.INT		42	43	III	OM.D.INT		20	57	23	I	OC.D.INT				
	3	24	44	I	PA.D.EXT		4	9	40	III		PA.F.INT	23	16	20	I	EC.F.INT			
	3	28	32	I	PA.D.INT		4	26	10	III		PA.F.EXT	23	20	7	I	EC.F.EXT			
	5	32	41	I	OM.F.INT		4	41	5	III		OM.F.INT	23	20	54	I	EC.F.PEN			
	5	34	45	I	PA.F.INT		4	55	12	III		OM.F.EXT	11	18	0	2	I	PA.D.EXT		
	5	36	28	I	OM.F.EXT		10	42	19	I		PA.D.EXT		18	3	50	I	PA.D.INT		
	5	38	33	I	PA.F.EXT		10	46	7	I		PA.D.INT		18	12	59	I	OM.D.EXT		
	13	56	16	II	EC.D.PEN		10	46	55	I		OM.D.EXT		18	16	45	I	OM.D.INT		
	13	58	5	II	EC.D.EXT		10	50	42	I		OM.D.INT		20	10	13	I	PA.F.INT		
	14	2	47	II	EC.D.INT		12	52	26	I		PA.F.INT		20	14	0	I	PA.F.EXT		
	16	24	56	II	OC.F.INT		12	56	14	I		PA.F.EXT		20	24	54	I	OM.F.INT		
	16	29	44	II	OC.F.EXT		12	58	48	I		OM.F.INT		20	28	41	I	OM.F.EXT		
	2	0	41	50	I		EC.D.PEN	13	2	34		I		OM.F.EXT	12	5	23	55	II	OC.D.EXT
		0	42	37	I		EC.D.EXT	22	14	58		II		PA.D.EXT		5	28	41	II	OC.D.INT
		0	46	24	I		EC.D.INT	22	19	44		II		PA.D.INT		8	16	14	II	EC.F.INT
2		54	25	I	OC.F.INT	22	24	53	II	OM.D.EXT	8	20		57		II	EC.F.EXT			
2		58	13	I	OC.F.EXT	22	29	32	II	OM.D.INT	8	22		46		II	EC.F.PEN			
12		22	1	III	EC.D.PEN	7	0	36	13	II	PA.F.INT	15		19		30	I	OC.D.EXT		
12		27	6	III	EC.D.EXT		0	41	0	II	PA.F.EXT	15		23		17	I	OC.D.INT		
12		42	16	III	EC.D.INT		0	51	25	II	OM.F.INT	17		45		0	I	EC.F.INT		
14		28	42	III	EC.F.INT		0	56	4	II	OM.F.EXT	17	48	47		I	EC.F.EXT			
14		43	52	III	EC.F.EXT		8	1	50	I	OC.D.EXT	17	49	34		I	EC.F.PEN			
14		48	57	III	EC.F.PEN		8	5	37	I	OC.D.INT	13	5	32		6	III	PA.D.EXT		
21		49	36	I	OM.D.EXT		10	19	0	I	EC.F.INT		5	48		18	III	PA.D.INT		
21		50	37	I	PA.D.EXT		10	22	46	I	EC.F.EXT		6	28		26	III	OM.D.EXT		
21		53	22	I	OM.D.INT		10	23	33	I	EC.F.PEN		6	42		29	III	OM.D.INT		
21		54	25	I	PA.D.INT		8	5	8	10	I		PA.D.EXT	7		25	47	III	PA.F.INT	
3		0	0	40	I			PA.F.INT	5	11	58		I	PA.D.INT		7	42	0	III	PA.F.EXT
	0	1	25	I	OM.F.INT			5	15	34	I		OM.D.EXT	8	41	55	III	OM.F.INT		
	0	4	28	I	PA.F.EXT			5	19	20	I		OM.D.INT	8	55	55	III	OM.F.EXT		
	0	5	12	I	OM.F.EXT			7	18	18	I		PA.F.INT	12	26	2	I	PA.D.EXT		
	9	6	52	II	OM.D.EXT			7	22	6	I		PA.F.EXT	12	29	49	I	PA.D.INT		
	9	8	18	II	PA.D.EXT			7	27	27	I		OM.F.INT	12	41	43	I	OM.D.EXT		
	9	11	31	II	OM.D.INT	7		31	14	I	OM.F.EXT		12	45	29	I	OM.D.INT			
	9	13	5	II	PA.D.INT	16		17	4	II	OC.D.EXT		14	36	14	I	PA.F.INT			
	11	29	22	II	PA.F.INT	16		21	51	II	OC.D.INT		14	40	1	I	PA.F.EXT			
	11	33	22	II	OM.F.INT	18		58	0	II	EC.F.INT		14	53	39	I	OM.F.INT			
	11	34	9	II	PA.F.EXT	19		2	42	II	EC.F.EXT		14	57	25	I	OM.F.EXT			
	11	38	2	II	OM.F.EXT	19		4	32	II	EC.F.PEN	14	0	28	50	II	PA.D.EXT			
	19	10	5	I	OC.D.EXT	9		2	27	40	I		OC.D.EXT	0	33	35	II	PA.D.INT		
	19	13	53	I	OC.D.INT			2	31	28	I		OC.D.INT	1	1	5	II	OM.D.EXT		
	21	21	38	I	EC.F.INT			4	47	38	I		EC.F.INT	1	5	44	II	OM.D.INT		
	21	25	24	I	EC.F.EXT		4	51	25	I	EC.F.EXT		2	50	28	II	PA.F.INT			
21	26	12	I	EC.F.PEN	4		52	12	I	EC.F.PEN	2		55	13	II	PA.F.EXT				
4	16	16	26	I	PA.D.EXT		15	48	25	III	OC.D.EXT		3	27	39	II	OM.F.INT			
	16	18	14	I	OM.D.EXT		16	4	45	III	OC.D.INT		3	32	17	II	OM.F.EXT			
	16	20	14	I	PA.D.INT		18	30	7	III	EC.F.INT		9	45	30	I	OC.D.EXT			
	16	22	0	I	OM.D.INT		18	45	9	III	EC.F.EXT		9	49	17	I	OC.D.INT			
	18	26	31	I	PA.F.INT		18	50	11	III	EC.F.PEN		12	13	45	I	EC.F.INT			
	18	30	5	I	OM.F.INT		23	34	8	I	PA.D.EXT		12	17	31	I	EC.F.EXT			
	18	30	19	I	PA.F.EXT		23	37	55	I	PA.D.INT		12	18	18	I	EC.F.PEN			
	18	33	51	I	OM.F.EXT		23	44	18	I	OM.D.EXT		15	6	52	0	I	PA.D.EXT		
	5	3	10	2	II		OC.D.EXT	23	48	5	I			OM.D.INT	6	55	47	I	PA.D.INT	
		3	14	49	II		OC.D.INT	10	1	44	17			I	PA.F.INT	7	10	23	I	OM.D.EXT
		5	39	26	II		EC.F.INT		1	48	5	I		PA.F.EXT	7	14	10	I	OM.D.INT	
		5	44	9	II	EC.F.EXT	1		56	13	I	OM.F.INT		9	2	12	I	PA.F.INT		
		5	45	58	II	EC.F.PEN	1		59	59	I	OM.F.EXT		9	6	0	I	PA.F.EXT		
		13	35	55	I	OC.D.EXT	11		21	56	II	PA.D.EXT		9	22	20	I	OM.F.INT		
		13	39	43	I	OC.D.INT	11		26	42	II	PA.D.INT		9	26	6	I	OM.F.EXT		
		15	50	16	I	EC.F.INT	11		43	6	II	OM.D.EXT		18	31	23	II	OC.D.EXT		
15		54	3	I	EC.F.EXT	11	47		45	II	OM.D.INT	18		36	9	II	OC.D.INT			
15		54	50	I	EC.F.PEN	13	43		22	II	PA.F.INT	21		35	0	II	EC.F.INT			
6		2	17	53	III	PA.D.EXT	13		48	8	II	PA.F.EXT		21	39	43	II	EC.F.EXT		
		2	28	34	III	OM.D.EXT	14		9	39	II	OM.F.INT		21	41	32	II	EC.F.PEN		
		14	14	14	18	II	OM.F.EXT													

2012 - CONFIGURATIONS DES SATELLITES GALILÉENS DE JUPITER

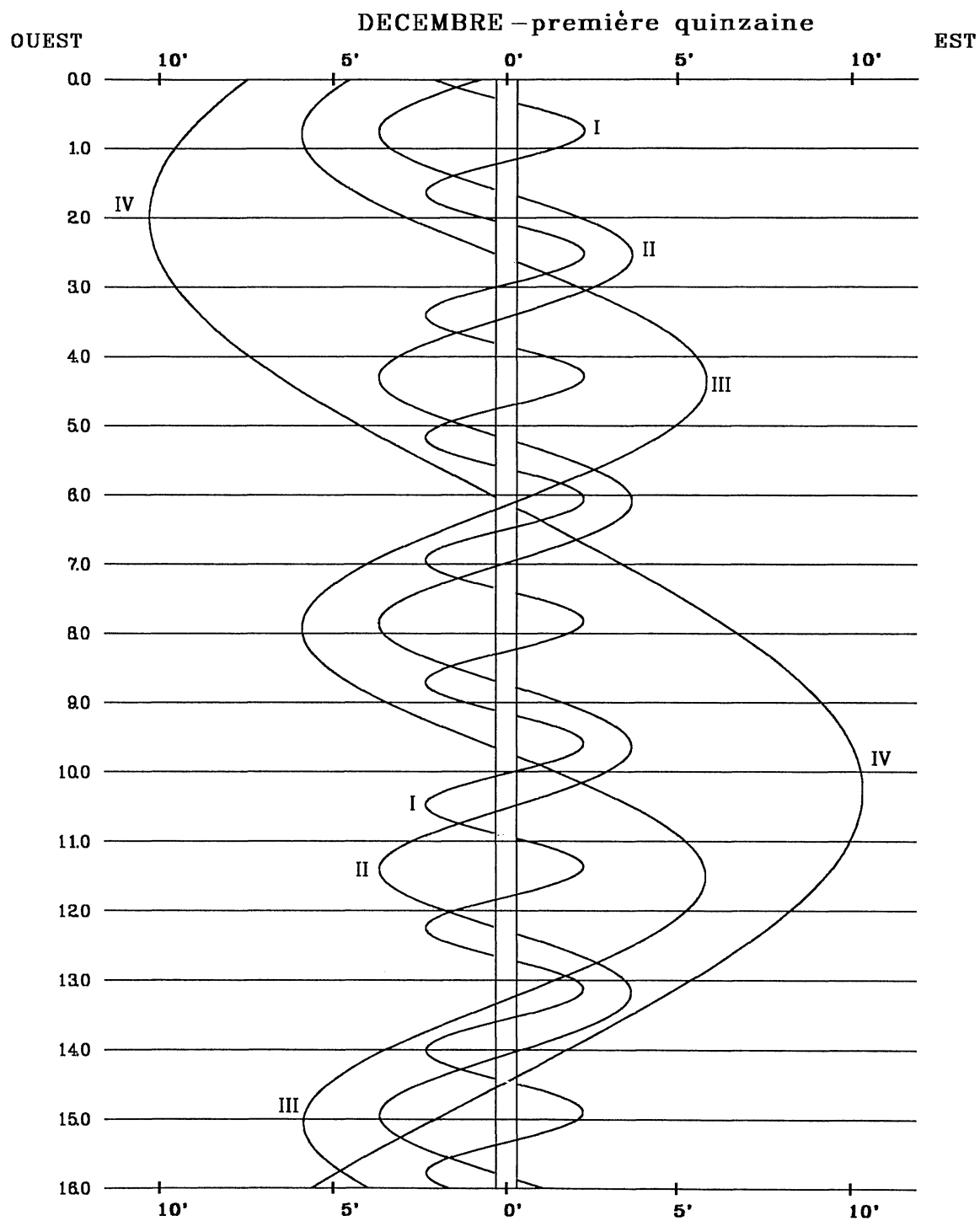

Dans le sens OUEST-EST, les satellites passent au-delà de Jupiter

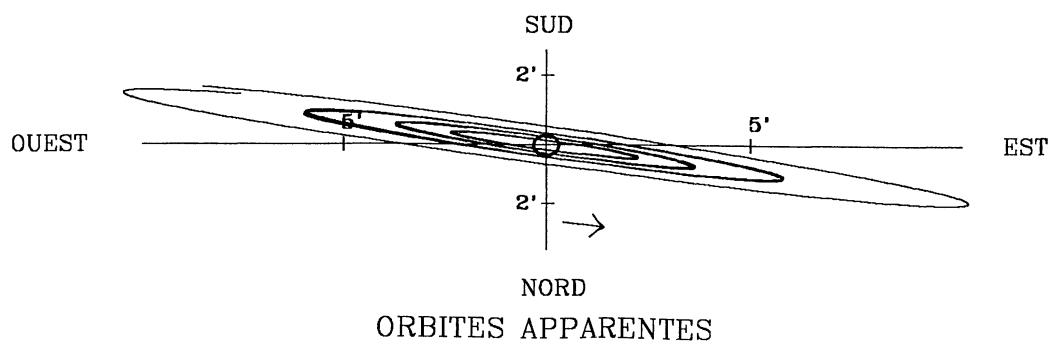

2012 - PHÉNOMÈNES DES SATELLITES GALILÉENS DE JUPITER
(Temps Terrestre)

DÉCEMBRE - DEUXIÈME QUINZAINE																			
jour	h	m	s	SAT.	TYPE	jour	h	m	s	SAT.	TYPE	jour	h	m	s	SAT.	TYPE		
16	4	11	27	I	OC.D.EXT		14	12	22	I	EC.F.EXT		15	55	25	I	PA.D.EXT		
	4	15	15	I	OC.D.INT		14	13	9	I	EC.F.PEN		15	59	12	I	PA.D.INT		
	6	42	25	I	EC.F.INT								16	31	45	I	OM.D.EXT		
	6	46	11	I	EC.F.EXT		22	8	36	28	I	PA.D.EXT		16	35	31	I	OM.D.INT	
	6	46	59	I	EC.F.PEN			8	40	15	I	PA.D.INT		16	45	2	III	OM.F.INT	
	19	4	0	III	OC.D.EXT			9	5	22	I	OM.D.EXT		16	58	48	III	OM.F.EXT	
	19	20	0	III	OC.D.INT			9	9	8	I	OM.D.INT		18	5	43	I	PA.F.INT	
	22	32	6	III	EC.F.INT			10	46	44	I	PA.F.INT		18	9	30	I	PA.F.EXT	
	22	46	58	III	EC.F.EXT			10	50	31	I	PA.F.EXT		18	43	42	I	OM.F.INT	
	22	51	58	III	EC.F.PEN			11	17	20	I	OM.F.INT		18	47	28	I	OM.F.EXT	
								11	21	6	I	OM.F.EXT							
								20	46	51	II	OC.D.EXT	28	4	59	48	II	PA.D.EXT	
								20	51	36	II	OC.D.INT		5	4	30	II	PA.D.INT	
17	1	18	5	I	PA.D.EXT								6	13	25	II	OM.D.EXT		
	1	21	53	I	PA.D.INT								6	18	1	II	OM.D.INT		
	1	39	10	I	OM.D.EXT		23	0	12	16	II	EC.F.INT		7	22	13	II	PA.F.INT	
	1	42	56	I	OM.D.INT			0	16	58	II	EC.F.EXT		7	26	55	II	PA.F.EXT	
	3	28	19	I	PA.F.INT			0	18	48	II	EC.F.PEN		8	39	55	II	OM.F.INT	
	3	32	7	I	PA.F.EXT			5	55	50	I	OC.D.EXT		8	44	32	II	OM.F.EXT	
	3	51	7	I	OM.F.INT			5	59	37	I	OC.D.INT		8	44	32	II	OM.F.EXT	
	3	54	54	I	OM.F.EXT			8	37	18	I	EC.F.INT		13	14	40	I	OC.D.EXT	
	13	36	11	II	PA.D.EXT			8	41	3	I	EC.F.EXT		13	18	26	I	OC.D.INT	
	13	40	55	II	PA.D.INT			8	41	51	I	EC.F.PEN		16	3	31	I	EC.F.INT	
	14	19	16	II	OM.D.EXT			22	20	58	III	OC.D.EXT		16	7	17	I	EC.F.EXT	
	14	23	54	II	OM.D.INT			22	36	39	III	OC.D.INT		16	8	4	I	EC.F.PEN	
	15	58	0	II	PA.F.INT														
	16	2	44	II	PA.F.EXT		24	0	19	23	III	OC.F.INT	29	10	21	47	I	PA.D.EXT	
	16	45	49	II	OM.F.INT			0	23	17	III	EC.D.PEN		10	25	34	I	PA.D.INT	
	16	50	26	II	OM.F.EXT			0	28	15	III	EC.D.EXT		11	0	30	I	OM.D.EXT	
	22	37	30	I	OC.D.EXT			0	35	3	III	OC.F.EXT		11	4	16	I	OM.D.INT	
	22	41	17	I	OC.D.INT			0	42	57	III	EC.D.INT		12	32	5	I	PA.F.INT	
								2	33	24	III	EC.F.INT		12	35	53	I	PA.F.EXT	
18	1	11	9	I	EC.F.INT			2	48	7	III	EC.F.EXT		13	12	26	I	OM.F.INT	
	1	14	55	I	EC.F.EXT			2	53	5	III	EC.F.PEN		13	16	12	I	OM.F.EXT	
	1	15	42	I	EC.F.PEN			3	2	45	I	PA.D.EXT		23	3	56	II	OC.D.EXT	
	19	44	9	I	PA.D.EXT			3	6	33	I	PA.D.INT		23	8	40	II	OC.D.INT	
	19	47	57	I	PA.D.INT			3	34	11	I	OM.D.EXT							
	20	7	53	I	OM.D.EXT			3	37	58	I	OM.D.INT	30	2	49	48	II	EC.F.INT	
	20	11	39	I	OM.D.INT			5	13	2	I	PA.F.INT		2	54	30	II	EC.F.EXT	
	21	54	24	I	PA.F.INT			5	16	50	I	PA.F.EXT		2	56	20	II	EC.F.PEN	
	21	58	11	I	PA.F.EXT			5	46	9	I	OM.F.INT		7	41	1	I	OC.D.EXT	
	22	19	50	I	OM.F.INT			5	49	55	I	OM.F.EXT		7	44	47	I	OC.D.INT	
	22	23	37	I	OM.F.EXT			15	51	37	II	PA.D.EXT		10	32	15	I	EC.F.INT	
								15	56	19	II	PA.D.INT		10	36	0	I	EC.F.EXT	
19	7	38	44	II	OC.D.EXT			16	55	25	II	OM.D.EXT		10	36	47	I	EC.F.PEN	
	7	43	30	II	OC.D.INT			17	0	2	II	OM.D.INT							
	10	53	22	II	EC.F.INT			18	13	49	II	PA.F.INT	31	1	40	53	III	OC.D.EXT	
	10	58	4	II	EC.F.EXT			18	18	32	II	PA.F.EXT		1	56	13	III	OC.D.INT	
	10	59	54	II	EC.F.PEN			18	18	32	II	PA.F.EXT		3	41	51	III	OC.F.INT	
	17	3	33	I	OC.D.EXT			19	21	56	II	OM.F.INT		3	57	12	III	OC.F.EXT	
	17	7	20	I	OC.D.INT			19	26	33	II	OM.F.EXT		4	23	22	III	EC.D.PEN	
	19	39	50	I	EC.F.INT									4	28	17	III	EC.D.EXT	
	19	43	36	I	EC.F.EXT			25	0	22	3	I	OC.D.EXT		4	42	51	III	EC.D.INT
	19	44	23	I	EC.F.PEN				3	6	2	I	EC.F.INT		4	48	19	I	PA.D.EXT
									3	9	48	I	EC.F.EXT		4	52	7	I	PA.D.INT
									3	10	35	I	EC.F.PEN		5	29	21	I	OM.D.EXT
20	8	48	7	III	PA.D.EXT			21	29	2	I	PA.D.EXT		5	33	7	I	OM.D.INT	
	9	3	59	III	PA.D.INT			21	32	49	I	PA.D.INT		6	34	40	III	EC.F.INT	
	10	28	36	III	OM.D.EXT			22	2	56	I	OM.D.EXT		6	49	13	III	EC.F.EXT	
	10	42	32	III	OM.D.INT			22	6	42	I	OM.D.INT		6	54	9	III	EC.F.PEN	
	10	43	58	III	PA.F.INT			23	39	19	I	PA.F.INT		6	58	38	I	PA.F.INT	
	10	59	52	III	PA.F.EXT			23	43	6	I	PA.F.EXT		7	2	25	I	PA.F.EXT	
	12	43	2	III	OM.F.INT									7	41	17	I	OM.F.INT	
	12	56	56	III	OM.F.EXT									7	45	3	I	OM.F.EXT	
	14	10	19	I	PA.D.EXT									18	8	35	II	PA.D.EXT	
	14	14	6	I	PA.D.INT		26	0	14	54	I	OM.F.INT		18	13	16	II	PA.D.INT	
	14	36	39	I	OM.D.EXT			0	18	40	I	OM.F.EXT		19	31	30	II	OM.D.EXT	
	14	40	26	I	OM.D.INT			9	54	56	II	OC.D.EXT		19	36	7	II	OM.D.INT	
	16	20	34	I	PA.F.INT			9	59	41	II	OC.D.INT		20	31	10	II	PA.F.INT	
	16	24	22	I	PA.F.EXT			13	30	43	II	EC.F.INT		20	35	52	II	PA.F.EXT	
	16	48	37	I	OM.F.INT			13	35	26	II	EC.F.EXT		21	57	58	II	OM.F.INT	
	16	52	23	I	OM.F.EXT			13	37	16	II	EC.F.PEN		22	2	34	II	OM.F.EXT	
								18	48	18	I	OC.D.EXT							
								18	52	5	I	OC.D.INT							
21	2	43	37	II	PA.D.EXT			21	34	45	I	EC.F.INT							
	2	48	20	II	PA.D.INT			21	38	30	I	EC.F.EXT	32	2	7	28	I	OC.D.EXT	
	3	37	15	II	OM.D.EXT			21	39	17	I	EC.F.PEN		2	11	15	I	OC.D.INT	
	3	41	53	II	OM.D.INT									5	1	0	I	EC.F.INT	
	5	5	38	II	PA.F.INT									5	4	46	I	EC.F.EXT	
	5	10	22	II	PA.F.EXT									5	5	33	I	EC.F.PEN	
	6	3	48	II	OM.F.INT		27	12	7	33	III	PA.D.EXT		23	14	51	I	PA.D.EXT	
	6	8	25	II	OM.F.EXT			12	23	5	III	PA.D.INT		23	18	38	I	PA.D.INT	
	6	8	25	II	OM.F.EXT			14	5	43	III	PA.F.INT		23	58	8	I	OM.D.EXT	
	11	29	42	I	OC.D.EXT			14	21	18	III	PA.F.EXT							
	11	33	29	I	OC.D.INT			14	29	40	III	OM.F.EXT							
	14	8	36	I	EC.F.INT			14	43	30	III	OM.D.INT							

2012 - CONFIGURATIONS DES SATELLITES GALILÉENS DE JUPITER

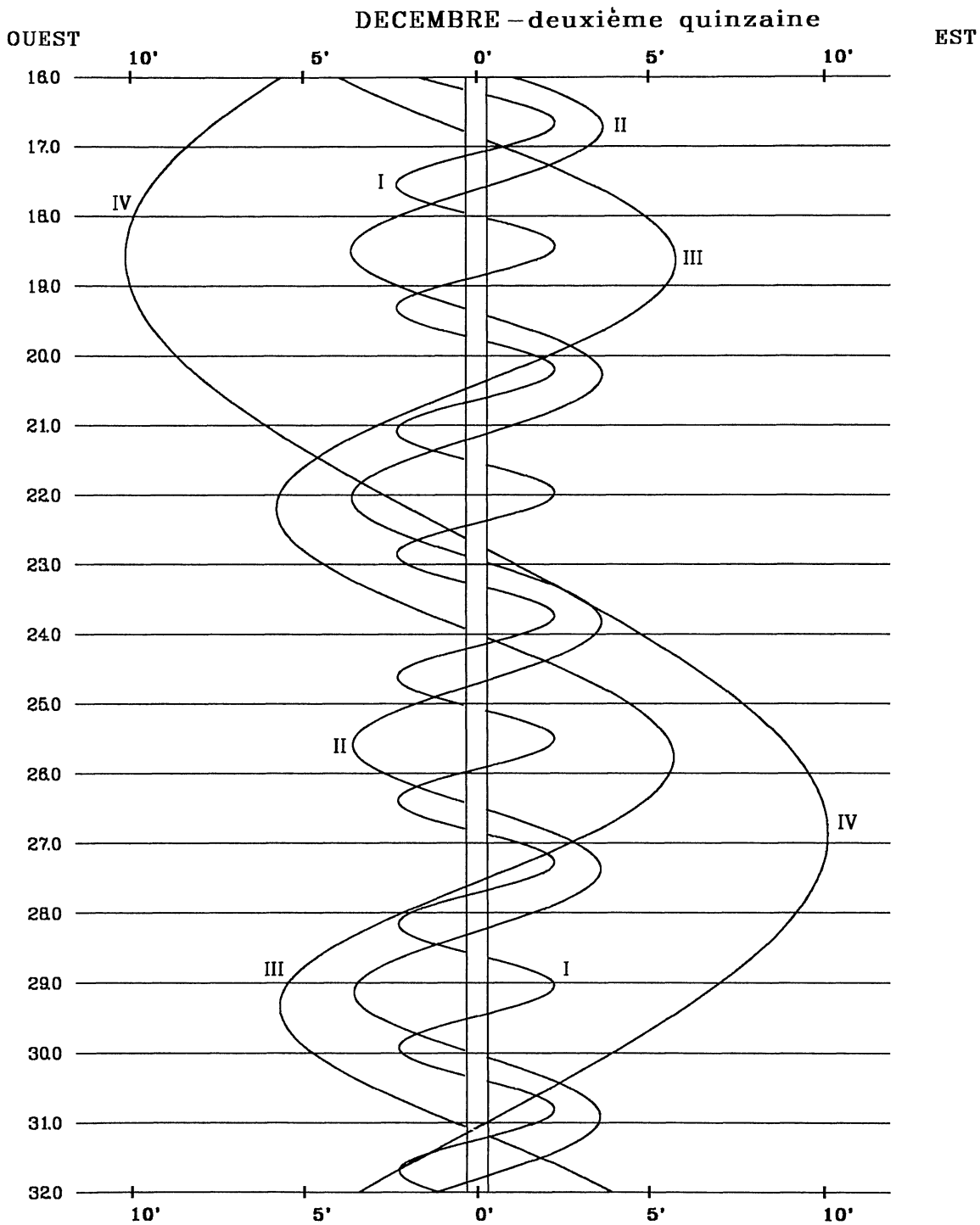

Dans le sens OUEST-EST, les satellites passent au-delà de Jupiter

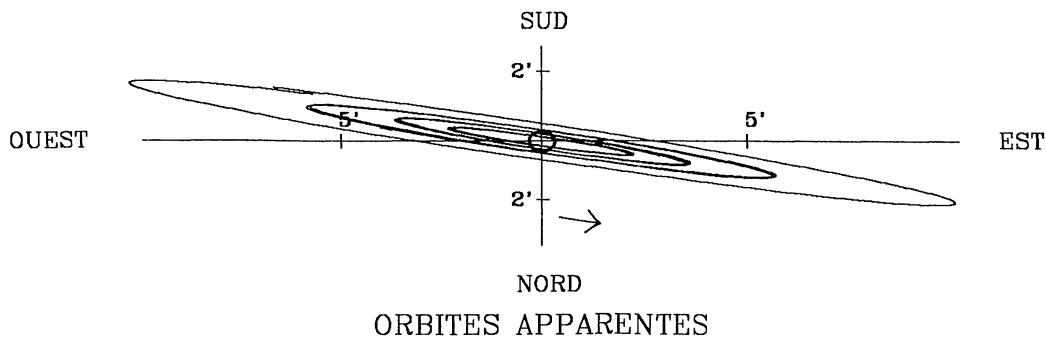

PHÉNOMÈNES POUR 2013

PHENOMENA FOR 2013

LES PHÉNOMÈNES POUR 2013

Pour l'année 2013, les phénomènes sont donnés par l'intermédiaire de coefficients d'un polynôme. On a ainsi une représentation sous une forme très condensée. La précision est cependant moins bonne que celle des prédictions des phénomènes pour 2012. Cette précision et la méthode pour déterminer les phénomènes sont données ci-après.

UTILISATION DES COEFFICIENTS

Soit P la période synodique moyenne d'un satellite; la date approchée T_1 du phénomène proche de la date T est donnée par la relation :

$$T_1 = KP + \tau/24 + T_0 \quad (1)$$

où K représente la partie entière de la quantité $(T - T_0)/P$ et où τ est donné, sur l'intervalle $(T_0, T_0 + DT)$ par un polynôme de la forme :

$$\tau = C_0 + C_1x + C_2x^2 + \dots + C_nx^n \quad (2)$$

avec

$$x = [2(T - T_0)/DT] - 1 \quad (3)$$

T_1 ayant été obtenu par la relation (1), on peut réitérer le calcul en substituant T_1 à T dans la formule (3) pour obtenir une date T_2 plus proche du phénomène recherché que T_1 . La précision de ce type de prédiction est meilleure que 60 secondes de temps.

Les tables donnent les coefficients C_i de la formule (2), numérotés à partir de C_0 pour les quatre satellites et pour les phénomènes:

- débuts et fins des éclipses des satellites par Jupiter (notés EC.D et EC.F),
- débuts et fins des occultations des satellites par Jupiter (notés OC.D et OC.F),
- débuts et fins des passages de l'ombre des satellites sur le disque de Jupiter (OM.D et OM.F),
- débuts et fins des passages des satellites devant la planète (PA.D et PA.F).

PHENOMENA FOR 2013

For 2013, the phenomena are given using polynomial coefficients. So, we have a compact representation. However, the accuracy is less than the one from the data given for 2012. This accuracy and the method of calculation of the phenomena are given here after.

USE OF THE COEFFICIENTS

Let P be the mean synodique period of a satellite; the approximate date T_1 of a phenomenon close to a date T is given by :

$$T_1 = KP + \tau/24 + T_0 \quad (1)$$

where K is the integer part of $(T - T_0)/P$ and where τ is given on the interval $(T_0, T_0 + DT)$ by a polynomial :

$$\tau = C_0 + C_1x + C_2x^2 + \dots + C_nx^n \quad (2)$$

with

$$x = [2(T - T_0)/DT] - 1 \quad (3)$$

The value T_1 deduced from equation (1) is then substituted in place of T in equation (3). The new iteration yields a date T_2 closer to the date of the phenomenon than T_1 . The precision of this type of prediction is better than 60 seconds of time.

The tables give the coefficients C_i in formula (2) numbered from C_0 for the four satellites and for the following phenomena:

- disappearance and reappearance of the satellites eclipsed by Jupiter (denoted respectively by EC.D and EC.F),
- disappearance and reappearance of the satellites occulted by Jupiter (denoted OC.D and OC.F),
- ingress and egress of the transits of the satellites shadow across the disc of Jupiter (OM.D and OM.F),
- ingress and egress of the satellites transits across the planet (PA.D and PA.F).

EXEMPLE D'UTILISATION

Déterminons les dates des phénomènes du satellite I (Io) au voisinage du 30 juin 2013.

Voyons tout d'abord le calcul pour le début d'éclipse pour lequel les tables donnent :

$$T_0 = 0; P = 1,769\,8605; DT = 366$$

Du 0 janvier au 30 juin 2013, 181 jours se sont écoulés, on a donc $T = 181$ et la formule (3) donne alors :

$$x = 2(181 - 0)/366 - 1 = -0,01092896$$

La formule (2) donne ensuite :

$\begin{aligned} \tau &= 27.085\,557 - 0.031\,013 \quad x - -0.031\,013 \quad x^2 \\ &+ \quad \quad \quad 0.063\,698 \quad x^3 + \quad \quad \quad 0.126\,535 \quad x^4 \end{aligned}$
--

d'où : $\tau = 18,227\,451$

On a d'autre part :

$$\begin{aligned} K &= \text{partie entière de } (181 - 0)/1,769\,8605 \\ &= 102 \end{aligned}$$

La formule (1) donne alors :

$$\begin{aligned} T_1 &= 102 \times 1,769\,8605 + 27.085\,858/24 + 0 \\ T_1 &= 181.654\,348 \text{ jours} \end{aligned}$$

depuis le 0 janvier (début de l'intervalle pour les éclipses) soit EC.D le 30 juin 2013 à 15h 42m 16s TT. Le calcul réitéré donne la même date.

On trouverait de même pour les autres phénomènes :

OC.D	le 30 juin à 15h 53m 9s
EC.F	le 30 juin à 17h 55m 40s
OC.F	le 30 juin à 18h 6m 54s
OM.D	le 29 juin à 18h 34m 51s
PA.D	le 29 juin à 18h 44m 38s
OM.F	le 29 juin à 20h 47m 57s
PA.F	le 29 juin à 20h 58m 16s

EXAMPLE

Let us find the dates of the phenomena of satellite I (Io) which take place near the 30th of June 2013.

Let us start with the computation of the disappearance for the eclipse of the satellite for which the tables gives :

$$T_0 = 0; P = 1.769\,8605; DT = 366$$

Between January 0 to June the 30th 2013, 181 days have elapsed: $T = 181$ and formula (3) gives :

$$x = 2(181 - 0)/366 - 1 = -0.01092896$$

Formula (2) then gives:

therefore $\tau = 27.085\,858$

On the other hand:

$$\begin{aligned} K &= \text{integer part of } (181 - 0)/1.769\,8605 \\ &= 102 \end{aligned}$$

Formula (1) then gives :

$$\begin{aligned} T_1 &= 102 \times 1.769\,8605 + 27.085\,858/24 + 0 \\ T_1 &= 181.654\,348 \text{ days} \end{aligned}$$

from January 0 (beginning of the interval for the occultations) that is June 30th 2013 at 15h 42m 16s TT. Another iteration gives the same date.

One would find as well for the other phenomena:

<i>OC.D</i>	<i>June the 30th</i>	<i>at 15h 53m 9s</i>
<i>EC.F</i>	<i>June the 30th</i>	<i>at 17h 55m 40s</i>
<i>OC.F</i>	<i>June the 30th</i>	<i>at 18h 6m 54s</i>
<i>OM.D</i>	<i>June the 29th</i>	<i>at 18h 34m 51s</i>
<i>PA.D</i>	<i>June the 29th</i>	<i>at 18h 44m 38s</i>
<i>OM.F</i>	<i>June the 29th</i>	<i>at 20h 47m 57s</i>
<i>PA.F</i>	<i>June the 29th</i>	<i>at 20h 58m 16s</i>

CONDITIONS D'EXISTENCE DES PHÉNOMÈNES

Le recouvrement des cônes d'ombre et de visibilité rend inexistant certains phénomènes. Ainsi avant (ou après) l'opposition de Jupiter, les fins (respectivement débuts) d'éclipse et les débuts (respectivement fins) d'occultations sont inobservables. Ceci ne pouvant être pris en compte dans la représentation, il est nécessaire que l'utilisateur vérifie les conditions d'existence pour les éclipses et les occultations en calculant les quatre phases EC.D, EC.F, OC.D et OC.F. Ainsi, dans l'exemple précédent, on a dans l'ordre chronologique :

EC.D le 30 juin à 15h 42m 16s observable

OC.D le 30 juin à 15h 53m 9s inobservable car éclipsé

EC.F le 30 juin à 17h 55m 40s inobservable car occulté

OC.F le 30 juin à 18h 6m 54s observable.

D'autre part, les caractéristiques de l'orbite du satellite IV (Callisto) font qu'il n'existe pas toujours de phénomènes. Les coefficients relatifs à ce satellite ne sont donc donnés que sur l'intervalle où ils existent.

CONDITIONS FOR THE EXISTENCE OF THE PHENOMENA

As the visibility and shadow cones may sometimes overlap, some of the computed phenomena may not exist. Thus, before (or after) the opposition of Jupiter, the reappearances (respectively the disappearances) for the eclipses, and the disappearances (respectively reappearances) for the occultations are not observable. This could not be taken into account in the representation; so the user will have to check the existence conditions of the eclipses and occultations by computing the four steps EC.D, EC.F, OC.D and OC.F. For instance, in the example above one has, in chronological order :

EC.D June 30th at 15h 42m 16s observable

OC.D June 30th at 15h 53m 9s unobservable as eclipsed

EC.F June 30th at 17h 55m 40s unobservable as occulted

OC.F June 30th at 18h 6m 54s observable.

Moreover, the orbit of satellite IV (Callisto) is such that phenomena are not always present. The coefficients for this satellite are given on the interval for which they exist.

**2013- COEFFICIENTS DES PHÉNOMÈNES
DES SATELLITES GALILÉENS DE JUPITER**

72

SATELLITE 1		P = 1.7698605jours		TO = 0		DT = 366jours	
EC.D		EC.F		OM.D		OM.F	
0	27.085 557	0	29.309 437	0	5.962 712	0	8.181 067
1	-0.031 013	1	0.028 682	1	0.021 965	1	0.037 590
2	-0.313 551	2	-0.310 369	2	-0.647 389	2	-0.714 509
3	0.063 698	3	0.044 934	3	0.014 571	3	0.037 633
4	0.126 535	4	0.124 631	4	0.249 759	4	0.319 995
OC.D		OC.F		PA.D		PA.F	
0	27.290 059	0	29.518 323	0	6.163 456	0	8.389 126
1	3.108 334	1	3.194 062	1	3.122 195	1	3.140 459
2	-0.704 616	2	-0.687 684	2	-1.170 707	2	-1.278 497
3	-2.757 249	3	-2.819 339	3	-2.793 157	3	-2.725 149
4	-0.398 226	4	-0.435 533	4	0.000 777	4	0.178 546
5	0.075 362	5	0.099 494	5	0.102 275	5	0.058 946
6	0.431 222	6	0.444 705	6	0.291 175	6	0.209 074

TO = 0 correspond au 0 janvier 2013 0h soit la date julienne 2456292.5

SATELLITE 2		P = 3.5540942jours		TO = 0		DT = 366jours	
EC.D		EC.F		OM.D		OM.F	
0	62.616 403	0	65.158 067	0	19.492 594	0	22.023 533
1	0.014 962	1	0.113 760	1	-0.040 036	1	0.130 552
2	-1.379 049	2	-1.374 831	2	0.282 477	2	0.230 152
3	0.037 051	3	0.060 955	3	0.070 734	3	0.043 174
4	0.567 506	4	0.574 674	4	-0.169 438	4	-0.096 548
OC.D		OC.F		PA.D		PA.F	
0	63.027 652	0	65.585 097	0	19.893 270	0	22.444 953
1	6.130 791	1	6.284 353	1	6.048 518	1	6.284 375
2	-2.713 775	2	-2.615 646	2	-0.345 170	2	-0.360 261
3	-4.230 523	3	-4.262 220	3	-4.262 951	3	-4.399 962
4	0.598 012	4	0.429 205	4	-1.518 651	4	-1.475 607
5	-2.562 273	5	-2.531 124	5	-2.429 624	5	-2.323 367
6	0.316 341	6	0.371 220	6	1.023 756	6	0.981 253
7	1.530 666	7	1.521 370	7	1.480 237	7	1.435 990

TO = 0 correspond au 0 janvier 2013 0h soit la date julienne 2456292.5

**2013- COEFFICIENTS DES PHÉNOMÈNES
DES SATELLITES GALILÉENS DE JUPITER**

SATELLITE 3		P = 7.1663872jours		T0 = 0		DT = 366jours	
EC.D		EC.F		OM.D		OM.F	
0	4.815 188	0	7.520 039	0	91.021 054	0	93.707 033
1	-0.077 599	1	0.431 307	1	-0.069 667	1	0.415 385
2	-0.418 136	2	-0.439 845	2	-0.624 414	2	-0.730 799
3	0.091 307	3	0.071 750	3	0.005 209	3	0.045 465
4	0.132 330	4	0.132 887	4	0.216 706	4	0.303 936
5	-0.026 372	5	-0.029 017	5	0.022 384	5	-0.014 699
OC.D		OC.F		PA.D		PA.F	
0	29.563 293	0	32.320 712	0	115.755 872	0	118.499 860
1	12.284 187	1	13.039 117	1	12.157 454	1	12.885 716
2	-2.237 944	2	-2.053 693	2	-2.480 301	2	-2.475 838
3	-8.563 606	3	-8.988 480	3	-8.419 224	3	-8.812 699
4	-1.040 488	4	-1.543 716	4	-0.906 380	4	-1.093 787
5	-5.166 959	5	-4.771 230	5	-5.355 901	5	-4.922 833
6	1.222 578	6	1.394 061	6	1.229 542	6	1.254 147
7	3.051 291	7	2.915 033	7	3.189 957	7	3.012 653

TO = 0 correspond au 0 janvier 2013 0h soit la date julienne 2456292.5

SATELLITE 4		P = 16.7535520jours		T0 = 180		DT = 186jours	
EC.D		EC.F		OM.D		OM.F	
0	309.963 431	0	312.267 473	0	110.802 323	0	113.041 887
1	-0.746 731	1	0.655 265	1	-0.765 787	1	0.637 759
2	0.136 943	2	-0.384 083	2	0.289 916	2	-0.165 315
3	-0.016 877	3	0.194 296	3	-0.143 520	3	0.199 203
4	0.162 039	4	0.268 997	4	-0.761 997	4	-1.160 756
5	-0.271 304	5	-0.041 090	5	0.333 145	5	0.724 270
6	0.193 301	6	-0.629 992	6	1.520 776	6	1.318 378
7	-0.041 389	7	0.428 335	7	-1.122 584	7	-1.098 305
OC.D		OC.F		PA.D		PA.F	
0	321.865 472	0	324.957 672	0	122.616 496	0	125.650 795
1	2.474 652	1	3.642 745	1	2.383 367	1	3.510 442
2	-11.648 443	2	-12.497 495	2	-11.555 822	2	-12.439 499
3	-4.644 793	3	-4.664 497	3	-4.569 528	3	-4.434 502
4	0.532 075	4	0.416 341	4	0.401 240	4	0.602 293
5	1.357 980	5	1.710 593	5	1.479 750	5	1.480 092
6	0.618 594	6	0.536 549	6	0.772 816	6	0.292 474
7	-0.039 188	7	-0.092 014	7	-0.255 113	7	0.063 536

TO = 0 correspond au 0 janvier 2013 0h soit la date julienne 2456292.5

