



HAL
open science

Satellites galiléens de Jupiter : phénomènes et configurations pour 2006, suivis d'une méthode permettant de calculer les phénomènes pour 2007

Th. Derouazi, S. Lemaître, Ch. Ruatti

► To cite this version:

Th. Derouazi, S. Lemaître, Ch. Ruatti. Satellites galiléens de Jupiter : phénomènes et configurations pour 2006, suivis d'une méthode permettant de calculer les phénomènes pour 2007. [Rapport de recherche] Institut de mécanique céleste et de calcul des éphémérides (IMCCE). 2006, 73 p. hal-01464910

HAL Id: hal-01464910

<https://hal-lara.archives-ouvertes.fr/hal-01464910v1>

Submitted on 10 Feb 2017

HAL is a multi-disciplinary open access archive for the deposit and dissemination of scientific research documents, whether they are published or not. The documents may come from teaching and research institutions in France or abroad, or from public or private research centers.

L'archive ouverte pluridisciplinaire **HAL**, est destinée au dépôt et à la diffusion de documents scientifiques de niveau recherche, publiés ou non, émanant des établissements d'enseignement et de recherche français ou étrangers, des laboratoires publics ou privés.

SATELLITES GALILÉENS DE JUPITER
PHÉNOMÈNES ET CONFIGURATIONS POUR 2006
SUIVIS D'UNE MÉTHODE PERMETTANT DE CALCULER LES
PHÉNOMÈNES POUR 2007



Supplément à la **CONNAISSANCE DES TEMPS**
à l'usage des observateurs

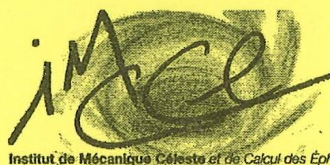

Institut de Mécanique Céleste et de Calcul des Ephémérides

Institut de mécanique céleste et de calcul des éphémérides
UMR 8028 du CNRS – Observatoire de Paris

.

4

2

SATELLITES GALILÉENS DE JUPITER
PHÉNOMÈNES ET CONFIGURATIONS POUR 2006
SUIVIS D'UNE MÉTHODE PERMETTANT DE CALCULER LES
PHÉNOMÈNES POUR 2007

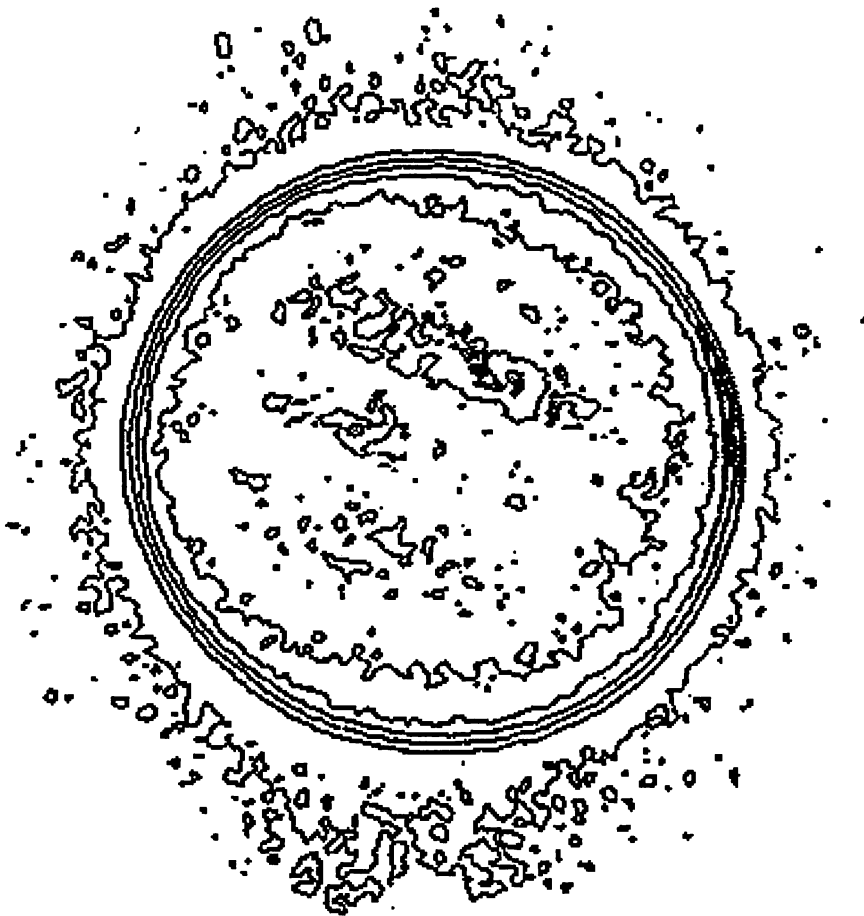

Supplément à la **CONNAISSANCE DES TEMPS**
à l'usage des observateurs

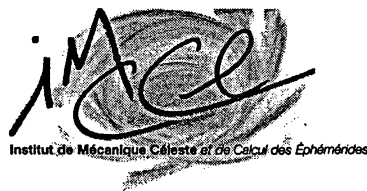

Institut de mécanique céleste et de calcul des éphémérides
UMR 8028 du CNRS – Observatoire de Paris

SATELLITES GALILÉENS DE JUPITER
GALILEAN SATELLITES OF JUPITER

**PHÉNOMÈNES ET CONFIGURATIONS POUR 2006, SUIVIS D'UNE
MÉTHODE PERMETTANT DE CALCULER LES PHÉNOMÈNES POUR 2007**

**PHENOMENA AND CONFIGURATIONS FOR 2006, FOLLOWED BY A
METHOD FOR THE CALCULATION OF THE PHENOMENA FOR 2007**

**Supplément à la CONNAISSANCE DES TEMPS
à l'usage des observateurs**

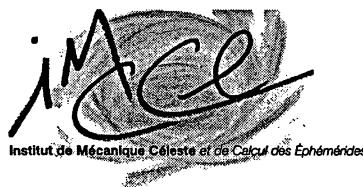

**Institut de mécanique céleste et de calcul des éphémérides
UMR 8028 du CNRS – Observatoire de Paris**

ISSN 0769 – 1033

Dépôt légal : Janvier 2006

**LES SERVEURS SUR INTERNET
DE L'INSTITUT DE MÉCANIQUE CÉLESTE
ET DE CALCUL DES ÉPHÉMÉRIDES**

<http://www.imcce.fr> et <ftp://ftp.imcce.fr>

L'*Institut de mécanique céleste et de calcul des éphémérides* diffuse de nombreuses informations, périodiquement remises à jour, grâce à ses serveurs sur le réseau *Internet*. Outre des informations générales sur l'histoire et les activités de l'*Institut de mécanique céleste et de calcul des éphémérides*, on peut y trouver des données scientifiques concernant les objets du système solaire :

- éphémérides de planètes et de satellites, phénomènes ;
- données sur les objets du système solaire ;
- éléments orbitaux de comètes et d'astéroïdes ;
- données sur les éclipses du Soleil ;
- bases de données astrométriques.
- images astronomiques.

Un serveur WEB est accessible à l'adresse <http://www.imcce.fr>. Un serveur ftp anonyme est accessible à l'adresse: <ftp://ftp.imcce.fr>.

***THE INTERNET SERVERS
OF THE INSTITUT DE MÉCANIQUE CÉLESTE
ET DE CALCUL DES ÉPHÉMÉRIDES***

<http://www.imcce.fr> and <ftp://ftp.imcce.fr>

The Institut de mécanique céleste et de calcul des éphémérides publishes information thanks to Internet servers. Besides general information concerning history and activities of the Institut de mécanique céleste et de calcul des éphémérides, one may access scientific data on:

- *ephemerides of planets and satellites, phenomena;*
- *data on the objects of the Solar system;*
- *orbital elements of comets and asteroids;*
- *data on solar eclipses;*
- *astronomical data base.*
- *astronomical images.*

The address of the WEB Server is: <http://www.imcce.fr>. One can also access an anonymous-ftp server at the address: <ftp://ftp.imcce.fr>.

**PUBLICATIONS DE L'INSTITUT DE MÉCANIQUE CÉLESTE
ET DE CALCUL DES ÉPHÉMÉRIDES
(Bureau des longitudes - Observatoire de Paris)**

**Publications éditées par EDP Sciences,
17, avenue du Hoggar, Z.I. de Courtabœuf, B.P. 112, F-91944 Les Ulis Cedex A**

Annuaire du Bureau des longitudes 2006.

Introduction aux éphémérides astronomiques. Supplément explicatif

à la Connaissance des Temps, épuisé

Les éclipses de Soleil. L'éclipse totale du 11 août 1999.

Le passage de Vénus.

Le manuel des éclipses

**Publications éditées par Edinautic,
13, rue du Vieux Colombier, F-75006 Paris**

Éphémérides Nautiques 2006.

**Publications éditées par Dunod,
5, rue Laromiquière, F-75006 Paris**

Cahiers des Sciences de l'Univers, publiés sous l'égide du Bureau des longitudes.

- 1. Les profondeurs de la Terre par J.-P. Poirier (1991).*
- 2. Stratosphère et couche d'ozone par G. Mégie (1992).*
- 3. Chronique de l'espace-temps – Du vide quantique à l'expansion cosmique par
A. Mazure, G. Mathez, Y. Mellier (1994).*
- 4. Les fondements de la mesure du temps par Cl. Audoin, B. Guinot (1998).*

**Publications éditées par l'Institut de mécanique céleste et de calcul des éphémérides,
CNRS – UMR8028, IMCCE, Service des ventes, 77, avenue Denfert-Rochereau, F-75014 Paris**

Suppléments à la Connaissance des Temps.

*Éphémérides des satellites faibles de Jupiter (VI, VII, VIII, IX, X, XI, XII et XIII)
et de Saturne (IX).*

Satellites galiléens de Jupiter. Phénomènes et configurations .

Satellites de Saturne I à VIII. Configurations.

Le calendrier républicain (réédition, 1994).

Notes scientifiques et techniques de l'Institut de Mécanique Céleste et de Calcul des éphémérides.

Encyclopédie scientifique de l'univers.

La physique (1981).

La Terre, les eaux, l'atmosphère (réédition, 1984), épuisé.

Les étoiles, le système solaire (réédition, 1986).

La galaxie, l'univers extragalactique (réédition, 1988).

Table des matières	Page
Avertissement	7
Données sur les satellites galiléens	9
Théorie du mouvement des satellites galiléens	10
Présentation des éphémérides	11
Phénomènes et configurations pour 2006	17
Phénomènes pour 2007	67

<i>Table of contents</i>	<i>Page</i>
<i>Foreword</i>	<i>7</i>
<i>Data on the Galilean satellites</i>	<i>9</i>
<i>Theory of the motion of the Galilean satellites</i>	<i>10</i>
<i>Presentation of the ephemerides</i>	<i>11</i>
<i>Phenomena and configurations for 2006</i>	<i>17</i>
<i>Phenomena for 2007</i>	<i>67</i>

Avertissement

À partir de 1996, des éphémérides des satellites naturels ont été publiées dans la *Connaissance des Temps*. Ces éphémérides sont fournies par un logiciel à partir de 2006. Elles donnent les positions des satellites de Mars, des satellites galiléens de Jupiter, des huit premiers satellites de Saturne et des cinq satellites d'Uranus avec une précision proche de celle des théories originales.

Cependant, des observateurs ont souhaité continuer à disposer d'un ouvrage permettant d'identifier les satellites galiléens et de connaître les instants des phénomènes présentés par ces satellites et calculés à une seconde de temps près. En particulier, les configurations précises permettent très facilement de situer les satellites avec une précision de 10'' par rapport à Jupiter.

On trouvera aussi des renseignements généraux sur les satellites galiléens en début d'ouvrage ainsi qu'une méthode de calcul des phénomènes pour l'année suivante en fin d'ouvrage.

Foreword

Starting from 1996, ephemerides of natural Satellites have been published in the Connaissance des Temps and are available in a software starting from 2006. They give the positions of the satellite of Mars, of the Galilean satellites of Jupiter, of the first eight satellites of Saturn and of the five satellites of Uranus under. The accuracy is near that of the original theories.

However, observers wish to keep ephemerides allowing to identify immediately the Galilean satellites and to know the dates of the phenomena which are calculated to the nearest second of time. This is given by the present booklet, particularly the configurations giving positions with an accuracy of 10'' relatively to Jupiter.

Besides these informations, the present booklet gives various data concerning the Galilean Satellites. We also present a method which permits the calculation of the phenomena for the next year.

J.-E. Arlot

W. Thuillot

Responsables de la publication

Rédaction et calculs : Th. Derouazi, S. Lemaître, Ch. Ruatti.

DONNÉES SUR LES SATELLITES GALILÉENS
DATA ON THE GALILEAN SATELLITES

	IO (I)	EUROPE (II)	GANYMÈDE (III)	CALLISTO (IV)
<i>Masses</i> (10^{-5} masse de Jupiter)				
Sampson (1921)	4.50	2.54	7.99	4.50
De Sitter (1931)	3.81	2.48	8.17	5.09
Pioneer 11 (1976)	4.68	2.52	7.80	5.66
Fukushima (1990)	4.705	2.525	7.803	5.667
<i>Rayons</i> (km)				
Danjon (1954)	1650	1400	2450	2300
Dollfus (1961)	1775	1550	2800	2525
Pioneer 11 (1976)	1840	1552	2650	2420
Davies et al. (1996)	1821	1565	2634	2403
<i>Magnitudes visuelles</i> à l'opposition de Jupiter				
Harris (1961)	4.8	5.2	4.5	5.5
<i>Albédos géométriques</i> (Harris, 1961)				
U : 353 nm	0.19	0.47	0.29	0.14
B : 448 nm	0.56	0.67	0.41	0.21
V : 554 nm	0.92	0.83	0.49	0.26
R : 690 nm	1.12	0.93	0.56	0.30
I : 820 nm	1.15	0.95	0.57	0.31
<i>Albédo de Bond</i> (visuel)				
	0.54	0.49	0.29	0.15
<i>Demi-grand axe</i> (Sampson, 1921)				
en UA	0.002 820	0.004 486	0.007 155	0.012 586
en rayons de Jupiter	5.87	9.34	14.91	26.22
en kilomètres	421 810	671 140	1 070 500	1 882 900
<i>Plus grande élongation</i> à l'opposition de Jupiter (minutes et secondes de degré)				
Sampson (1921)	2'17"	3'40"	5'48"	10'13"
<i>Période synodique</i> (jours)				
Sampson (1921)	1.769 860 488 3	3.554 094 174 2	7.166 387 229 2	16.753 552 300 7
<i>Inclinaison moyenne sur</i> l'équateur de Jupiter pour 2006.5 (minutes et secondes de degré)				
Sampson (1921)	1'26"	28'44"	6'04"	24'36"
<i>Valeur moyenne de l'excentricité</i> pour 2006.5				
Sampson (1921)	0.004	0.009	0.001	0.007
<i>Partie séculaire du mouvement</i> (degré par an)				
noeud	-48.5	-11.9	-2.6	-0.6
périjove	57.0	14.6	2.7	0.7
Sampson (1921)				

THÉORIE DU MOUVEMENT
DES SATELLITES GALILÉENS

THEORY OF THE MOTION OF
THE GALILEAN SATELLITES

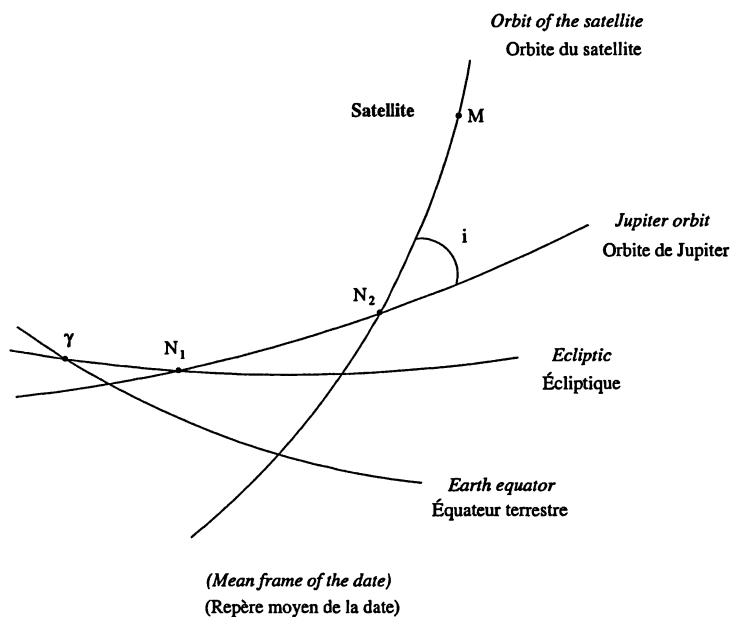

Du fait de la complexité du mouvement des satellites galiléens, il est difficile de donner des valeurs précises pour les nœuds et les périjoves. En effet, les excentricités et les inclinaisons sont faibles (cf. tableau précédent) et tous ces éléments sont soumis à de grandes variations (Thuillot, Vu, 1985).

On donne ci-après les longitudes moyennes (d'après Sampson, 1921) dans le plan des orbites, ce plan étant confondu avec l'équateur de Jupiter.

Si τ est le temps en jours moyens compté à partir de 1900,0 on a :

Because of the complexity of the motion of the Galilean Satellites of Jupiter it is difficult to provide precise values for nodes and perijoves. Indeed, eccentricities and inclinations are small (see the preceding table) and all these elements undergo large variations (Thuillot, Vu, 1985).

The mean longitudes (Sampson, 1921) in the orbital planes identified with Jupiter's equator are given below.

If τ is the time in days which has elapsed from 1900.0, one gets:

$\gamma N_1 N_2 = 316^\circ.051 + 0.000\,035\,59 \tau$, $i = 3^\circ.103\,50$					
$\gamma N_1 + N_1 N_2 + N_2 M =$				Période sidérale en jours Sidereal period in days	
Io	42° .599 87	+	203.488 992 435	τ	1.769 137 463 9
Europe	99° .550 81	+	101.374 761 672	τ	3.551 179 742 0
Ganymede	168° .026 28	+	50.317 646 290	τ	7.154 547 689 4
Callisto	234° .407 90	+	21.571 109 630	τ	16.688 988 474 6

PRÉSENTATION DES ÉPHÉMÉRIDES
PRESENTATION OF THE EPHEMERIDES

ÉCHELLES DE TEMPS

L'argument "temps" des éphémérides publiées ici est le TT (temps terrestre) proche du TE (temps des éphémérides) et réalisé physiquement par la mesure du TAI (temps atomique international). On a :

$$TT = TAI + 32,184 \text{ s}$$

Les événements astronomiques étant mesurés dans l'échelle UTC (temps universel coordonné), le tableau ci-dessous donne la relation entre TT et UTC (d'après la relation entre TAI et UTC publiée par l'IERS).

	<i>TT - UTC</i>
du 1 juillet 1994 au 1 janvier 1996.....	61,184 s
du 1 janvier 1996 au 1 juillet 1997.....	62,184 s
du 1 juillet 1997 au 1 janvier 1999.....	63,184 s
du 1 janvier 1999 au 1 janvier 2006.....	64,184 s
depuis le 1 janvier 2006	65,184 s

**PHÉNOMÈNES DES SATELLITES
GALILÉENS**

Les hypothèses utilisées pour le calcul des époques des phénomènes (Thuillot, 1989) sont les suivantes :

- Jupiter est un ellipsoïde dont l'aplatissement a pour valeur 1/15,4 et dont le rayon équatorial est 71 492 km.

- Les satellites sont des sphères de rayon : 1821 km pour Io, 1565 km pour Europe, 2634 km pour Ganymède, 2403 km pour Callisto (Davies et al., 1996).

- Le Soleil est une sphère de rayon 695 980 km.

- Les dates sont données pour tout observatoire terrestre puisqu'on peut négliger l'effet de parallaxe dont la grandeur est plus faible que la précision des prédictions.

TIME-SCALES

The time argument of the ephemerides is TT (terrestrial time) close to the former definition of ET (ephemeris time) and physically made by measuring TAI (international atomic time), so that :

$$TT = TAI + 32.184 \text{ s}$$

Astronomical events are measured in the time-scale UTC (coordinate universal time). The table below gives the correspondence between TTT and UTC (using the relationship between TAI and UTC published by IERS).

	<i>TT - UTC</i>
<i>From July 1, 1994 to January 1, 1996...</i>	<i>61,184 s</i>
<i>From January 1, 1996 to July 1, 1997.....</i>	<i>62,184 s</i>
<i>From July 1, 1997 to January 1, 1999...</i>	<i>63,184 s</i>
<i>From January 1, 1999 to January 1, 2006...</i>	<i>64,184 s</i>
<i>Since January 1 2006.</i>	<i>65,184 s</i>

**PHENOMENA OF THE GALILEAN
SATELLITES**

The hypothesis made for the calculations of the dates of the phenomena (Thuillot, 1989) are :

- Jupiter is an ellipsoid the flatness of which is 1/15,4 and the equatorial radius of which is 71 492 km.

- The satellites are spheres the radius of which are : 1821 km for Io, 1565 km for Europe, 2634 km for Ganymede and 2403 km for Callisto (Davies et al., 1996).

- The Sun is a sphere the radius of which is 695 980 km.

- The dates are given for everywhere on Earth since no parallax effect has to be taken into account.

L'effet de phase est négligé pour les satellites, mais pris en compte pour la planète.

Les pages paires fournissent les dates des phénomènes que présentent ces satellites :

- les débuts et fins des passages des satellites devant la planète :

PA.D.INT et PA.D.EXT
PA.F.INT et PA.F.EXT

- les débuts et fins de leurs occultations (anciennement appelées immersions et émergences) :

OC.D.INT et OC.D.EXT
OC.F.INT et OC.F.EXT

- les débuts et fins des passages de leur ombre sur Jupiter :

OM.D.INT et OM.D.EXT
OM.F.INT et OM.F.EXT

- les débuts et fins des éclipses des satellites par Jupiter :

EC.D.INT, EC.D.EXT, EC.D.PEN
EC.F.INT, EC.F.EXT, EC.F.PEN

Les notations utilisées sont les suivantes :

- .D et .F désignent le début et la fin.

- .INT désigne les contacts intérieurs des satellites avec le cône d'ombre pour les éclipses et les passages des ombres sur Jupiter, et désigne les mêmes contacts avec le cône de visibilité pour les occultations et les passages devant la planète.

- .EXT désigne les contacts extérieurs des satellites avec le cône d'ombre pour les éclipses et les passages des ombres sur Jupiter, et désigne les mêmes contacts avec le cône de visibilité pour les occultations et les passages devant la planète.

- .PEN désigne uniquement pour les éclipses, le contact extérieur des satellites avec le cône de pénombre.

The phase defect is neglected on the satellites but taken into account for Jupiter.

Even pages give the dates of the phenomena :

- the beginnings and the ends of the transits of the satellites in front of Jupiter :

*PA.D.INT and PA.D.EXT
PA.F.INT and PA.F.EXT*

- the beginnings and the ends of the occultations of the satellites by Jupiter :

*OC.D.INT and OC.D.EXT
OC.F.INT and OC.F.EXT*

- the beginnings and the ends of the transits of the umbra of the satellites on the disk of Jupiter :

*OM.D.INT and OM.D.EXT
OM.F.INT and OM.F.EXT*

- the beginnings and the ends of the eclipses of the satellites by Jupiter :

*EC.D.INT, EC.D.EXT, EC.D.PEN
EC.F.INT, EC.F.EXT, EC.F.PEN*

The notations means :

- .D and .F mean beginning and end.

- .INT means :

*· interior contact satellite/shadow cone for the eclipses and transits of shadows on Jupiter,
· interior contact satellite/cone of visibility for the occultations and the transits.*

- .EXT means :

*· exterior contact satellite/shadow cone for the eclipses and transits of shadows on Jupiter,
· exterior contact satellite/cone of visibility for the occultations and the transits.*

- .PEN means exterior contact satellite/penumbra cone for the eclipses.

EXEMPLE

Le déroulement d'un début d'éclipse se fait ainsi :

- EC.D.PEN : contact extérieur du satellite avec le cône de pénombre (début de l'assombrissement).
- EC.D. EXT : contact extérieur avec le cône d'ombre.
- EC.D.INT : contact extérieur avec le cône d'ombre (assombrissement total).

On observera que les éclipses se produisent à l'ouest ou à l'est de la planète, suivant que l'on est avant ou après l'opposition. En général pour le premier et le deuxième satellite, on ne peut, avant l'opposition, observer que le début des éclipses suivi de la fin des occultations. Après l'opposition on ne peut observer que le début des occultations suivi de la fin des éclipses. Il est possible, d'autre part, que, en raison de l'inclinaison de l'équateur de Jupiter sur l'écliptique et de l'éloignement du satellite IV Callisto par rapport à la planète, aucun phénomène de ce satellite ne se produise.

EXAMPLE

A beginning of an eclipse occurs as follows :

- *EC.D.PEN: external contact of the satellite with the cone of penumbra (beginning of the penumbra).*
- *EC.D.EXT: external contact with the shadow cone.*
- *EC.D.INT: internal contact with the shadow cone (the satellite has disappeared in the umbra).*

Note that the eclipses occur west of the planet before the opposition. Most of time for the first and the second satellite, only the beginning of the eclipse followed by the end of the occultation are observable. On the other hand, it may happen that no phenomenon occurs for satellite IV because it is far from Jupiter and because of the inclination of the equator of Jupiter above the ecliptic.

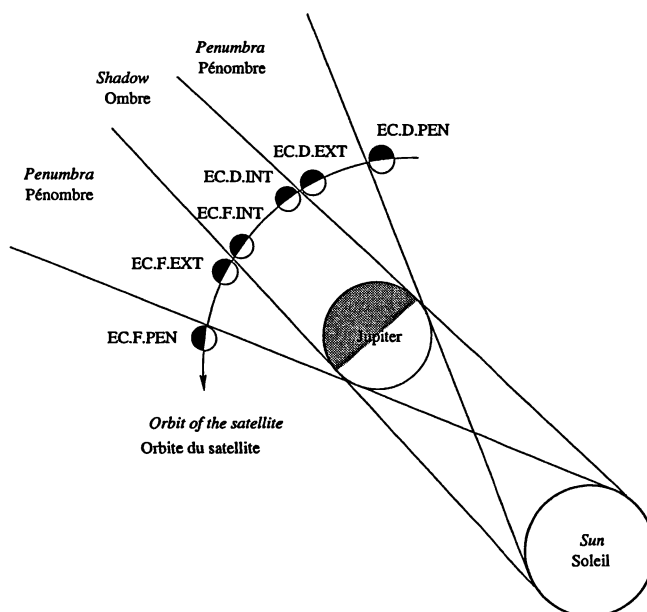

LES CONFIGURATIONS

Les configurations permettent d'identifier les satellites, et également de déterminer leur position en coordonnées tangentielles équatoriales relatives à Jupiter avec la précision suivante (pour une lecture des courbes à 0,5 mm près) :

- satellite 1: de 5'' à 20'' selon la vitesse apparente
- satellite 2: de 5'' à 10'' selon la vitesse apparente
- satellites 3 et 4: 5''

L'exemple suivant montre comment déterminer les positions des satellites :

On reporte en abscisse sur l'axe ouest-est les distances $\Delta\alpha \cos \delta$ mesurées pour une date voulue, sur les courbes. L'ordonnée est donnée par les orbites apparentes. L'indétermination avant/arrière est levée grâce au sens de rotation des satellites.

THE CONFIGURATIONS

The configurations permit to identify the satellites and to approach their positions relative to Jupiter in an equatorial tangential frame with the following precision (corresponding to a measure on the curves with an accuracy of 0,5 millimeter).

- Satellite 1: from 5'' to 20'' depending on the apparent velocity
- Satellite 2: from 5'' to 10'' depending on the apparent velocity
- Satellites 3 and 4: 5''

The following example shows how to determine the positions of the satellites :

For the abscissae, we have to project the differential coordinate $\Delta\alpha \cos \delta$ measured on the curves for a determined date on the East-West axis. For the ordinates, we have to project these abscissae on the apparent orbits as indicated on the figure. The front/back indetermination is removed thanks to the direction of the rotation of the satellites.

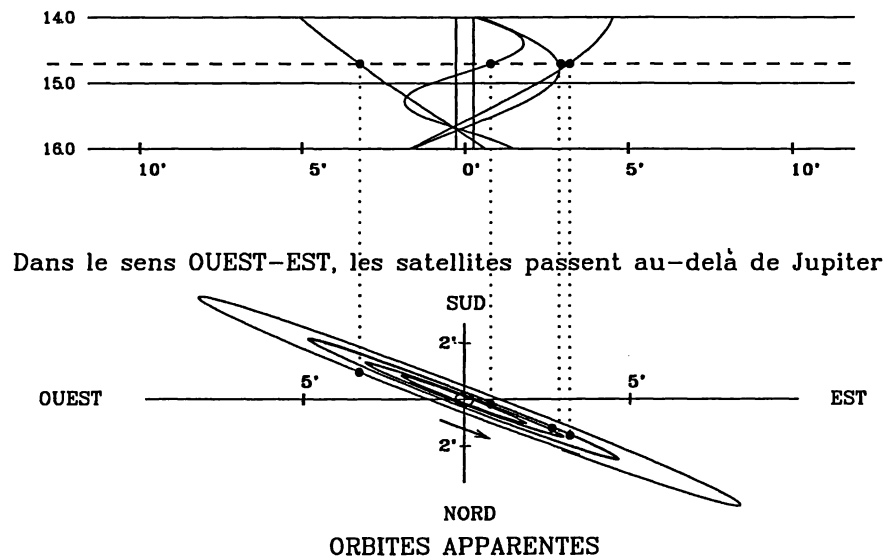

CALCULS DES PHÉNOMÈNES POUR 2007

Les prédictions des phénomènes des satellites galiléens sont données suivant une représentation polynomiale en fonction d'une variable temporelle. La méthode (Thuillot, 1983) permet une représentation compacte puisque moins de 13 coefficients suffisent à représenter chaque type de phénomène (passages, occultations, éclipses, passages d'ombre, débuts ou fins) de chaque satellite pour une année entière avec une précision de l'ordre de la minute de temps.

Des explications sur cette méthode, le formulaire et les tables de coefficients sont données pages 69 à 73.

CALCULATIONS OF THE DATES OF THE PHENOMENA FOR 2007

The predictions of the phenomena of the Galilean Satellites are given as a polynomial representation which depends directly on time. The method (Thuillot, 1983) allows a compact representation as less than 13 coefficients are sufficient to represent each type of phenomenon (transits, occultations, eclipses, shadow transits, beginnings or ends) for each satellite for a complete year with an accuracy of about one minute of time.

Some explanations about the method, the formulae and the tables of coefficients are given on pages 69 to 73.

RÉFÉRENCES

- Arlot, J.-E. : 1982, *Astron. Astrophys.* **107**, 305.
- Davies, M.E., Abalakin, V.K., Bursa, M., Lieske, J.H., Morando, B., Morrison, D., Seidelmann, P.K., Sinclair, A.T., Yallop, B., Tjuflin, Y.S. : 1996, Report of the IAU/IAG/COSPAR working group on cartographic coordinates and rotational elements of the planets and satellites: 1994, *Celest. Mech. Dyn. Astron.* **63**, 127.
- Lieske, J.H. : 1977, *Astron. Astrophys.* **56**, 333.
- Sampson, R.A. : 1921, *Mem. Roy. Astron. Soc.* **63**.
- Thuillot, W. : 1983, *Astron. Astrophys.* **127**, 63.
- Thuillot, W., Vu, D.T. : 1985, *Note Scientifique et Technique du Bureau des Longitudes* **S009**.
- Thuillot, W. : 1989, *Note Scientifique et Technique du Bureau des Longitudes* **S015**.

ÉPHÉMÉRIDES

**PHÉNOMÈNES ET CONFIGURATIONS
POUR 2006**

EPHEMERIDES

**PHENOMENA AND CONFIGURATIONS
FOR 2006**

2006 - PHÉNOMÈNES DES SATELLITES GALILÉENS DE JUPITER
(Temps Terrestre)

JANVIER - PREMIÈRE QUINZAINE																	
jour	h	m	s	SAT.	TYPE	jour	h	m	s	SAT.	TYPE	jour	h	m	s	SAT.	TYPE
0	13	41	38	II	EC.D.PEN	21	59	52	III	EC.F.INT	11	18	20	I	OM.F.EXT		
	13	43	14	II	EC.D.EXT	22	15	42	III	EC.F.EXT	12	20	34	I	PA.F.INT		
	13	47	38	II	EC.D.INT	22	20	34	III	EC.F.PEN	12	24	24	I	PA.F.EXT		
	15	29	9	I	EC.D.PEN	22	53	51	I	EC.D.PEN							
	15	29	53	I	EC.D.EXT	22	54	35	I	EC.D.EXT	11	5	35	45	II	EC.D.PEN	
	15	33	40	I	EC.D.INT	22	58	22	I	EC.D.INT	5	37	21	II	EC.D.EXT		
	18	24	26	II	OC.F.INT	23	51	56	II	PA.D.EXT	5	41	45	II	EC.D.INT		
	18	28	52	II	OC.F.EXT	23	56	17	II	PA.D.INT	6	18	30	I	EC.D.PEN		
	18	40	21	I	OC.F.INT						6	19	14	I	EC.D.EXT		
	18	44	9	I	OC.F.EXT	6	0	18	22	II	OM.F.INT	6	23	2	I	EC.D.INT	
						0	22	38	II	OM.F.EXT	9	35	12	I	OC.F.INT		
1	12	42	10	I	OM.D.EXT	0	27	38	III	OC.D.EXT	9	39	0	I	OC.F.EXT		
	12	45	59	I	OM.D.INT	0	44	34	III	OC.D.INT	10	29	45	II	OC.F.INT		
	13	44	41	I	PA.D.EXT	2	7	58	I	OC.F.INT	10	34	13	II	OC.F.EXT		
	13	48	31	I	PA.D.INT	2	11	46	I	OC.F.EXT							
	14	52	41	I	OM.F.INT	2	18	17	III	OC.F.INT	12	3	32	37	I	OM.D.EXT	
	14	56	30	I	OM.F.EXT	2	23	25	II	PA.F.INT	3	36	26	I	OM.D.INT		
	15	54	8	I	PA.F.INT	2	27	45	II	PA.F.EXT	4	40	45	I	PA.D.EXT		
	15	57	58	I	PA.F.EXT	2	35	13	III	OC.F.EXT	4	44	36	I	PA.D.INT		
2	5	49	39	III	OM.D.EXT	20	7	22	I	OM.D.EXT	5	42	57	I	OM.F.INT		
	6	4	24	III	OM.D.INT	20	11	11	I	OM.D.INT	5	46	46	I	OM.F.EXT		
	7	55	12	III	OM.F.INT	21	12	53	I	PA.D.EXT	6	49	46	I	PA.F.INT		
	8	10	8	III	OM.F.EXT	21	16	43	I	PA.D.INT	6	53	37	I	PA.F.EXT		
	8	27	18	II	OM.D.EXT	22	17	47	I	OM.F.INT	23	56	44	III	EC.D.PEN		
	8	31	34	II	OM.D.INT	22	21	36	I	OM.F.EXT							
	9	57	24	I	EC.D.PEN	23	22	7	I	PA.F.INT	13	0	1	37	III	EC.D.EXT	
	9	58	8	I	EC.D.EXT	23	25	57	I	PA.F.EXT	0	16	34	II	OM.D.EXT		
	10	1	55	I	EC.D.INT	7	16	17	23	II	EC.D.PEN	0	17	33	III	EC.D.INT	
	10	10	5	III	PA.D.EXT	16	19	0	II	EC.D.EXT	0	20	51	II	OM.D.INT		
	10	26	59	III	PA.D.INT	16	23	24	II	EC.D.INT	0	46	43	I	EC.D.PEN		
	10	31	30	II	PA.D.EXT	17	22	3	I	EC.D.PEN	0	47	27	I	EC.D.EXT		
	10	35	50	II	PA.D.INT	17	22	47	I	EC.D.EXT	0	51	14	I	EC.D.INT		
	11	2	2	II	OM.F.INT	17	26	35	I	EC.D.INT	1	57	12	III	EC.F.INT		
	11	6	18	II	OM.F.EXT	20	37	5	I	OC.F.INT	2	13	8	III	EC.F.EXT		
	12	0	34	III	PA.F.INT	20	37	5	I	OC.F.INT	2	18	1	III	EC.F.PEN		
	12	17	19	III	PA.F.EXT	20	40	53	I	OC.F.EXT	2	31	44	II	PA.D.EXT		
	13	3	18	II	PA.F.INT	21	8	1	II	OC.F.INT	2	36	6	II	PA.D.INT		
	13	7	38	II	PA.F.EXT	21	12	29	II	OC.F.EXT	2	50	57	II	OM.F.INT		
	13	9	36	I	OC.F.INT	8	14	35	50	I	OM.D.EXT	2	55	14	II	OM.F.EXT	
	13	13	24	I	OC.F.EXT	14	39	38	I	OM.D.INT	4	4	10	I	OC.F.INT		
3	7	10	31	I	OM.D.EXT	15	42	15	I	PA.D.EXT	4	7	59	I	OC.F.EXT		
	7	14	20	I	OM.D.INT	15	46	6	I	PA.D.INT	4	41	4	III	OC.D.EXT		
	8	14	5	I	PA.D.EXT	16	46	13	I	OM.F.INT	4	58	35	III	OC.D.INT		
	8	17	55	I	PA.D.INT	16	50	2	I	OM.F.EXT	5	2	32	II	PA.F.INT		
	9	21	0	I	OM.F.INT	17	51	25	I	PA.F.INT	5	6	53	II	PA.F.EXT		
	9	24	49	I	OM.F.EXT	17	55	15	I	PA.F.EXT	6	27	57	III	OC.F.INT		
	10	23	27	I	PA.F.INT	9	9	47	10	III	OM.D.EXT	6	45	28	III	OC.F.EXT	
	10	27	17	I	PA.F.EXT	10	2	0	III	OM.D.INT	22	0	59	I	OM.D.EXT		
4	2	59	58	II	EC.D.PEN	11	0	10	II	OM.D.EXT	22	4	48	I	OM.D.INT		
	3	1	34	II	EC.D.EXT	11	4	26	II	OM.D.INT	23	9	54	I	PA.D.EXT		
	3	5	58	II	EC.D.INT	11	50	17	I	EC.D.PEN	23	13	44	I	PA.D.INT		
	4	25	38	I	EC.D.PEN	11	51	1	I	EC.D.EXT	14	0	11	17	I	OM.F.INT	
	4	26	22	I	EC.D.EXT	11	51	53	III	OM.F.INT	0	15	6	I	OM.F.EXT		
	4	30	9	I	EC.D.INT	11	54	49	I	EC.D.INT	1	18	51	I	PA.F.INT		
	7	38	49	I	OC.F.INT	12	6	54	III	OM.F.EXT	1	22	41	I	PA.F.EXT		
	7	42	37	I	OC.F.EXT	13	12	0	II	PA.D.EXT	18	53	10	II	EC.D.PEN		
	7	46	52	II	OC.F.INT	13	12	0	II	PA.D.EXT	18	54	47	II	EC.D.EXT		
	7	51	18	II	OC.F.EXT	13	16	21	II	PA.D.INT	18	59	11	II	EC.D.INT		
5	1	38	59	I	OM.D.EXT	13	34	39	II	OM.F.INT	19	14	54	I	EC.D.PEN		
	1	42	48	I	OM.D.INT	13	38	56	II	OM.F.EXT	19	15	38	I	EC.D.EXT		
	2	43	33	I	PA.D.EXT	14	24	34	III	PA.D.EXT	19	19	26	I	EC.D.INT		
	2	47	23	I	PA.D.INT	14	42	5	III	PA.D.INT	22	33	6	I	OC.F.INT		
	3	49	26	I	OM.F.INT	15	6	10	I	OC.F.INT	22	36	54	I	OC.F.EXT		
	3	53	16	I	OM.F.EXT	15	9	58	I	OC.F.EXT	23	50	12	II	OC.F.INT		
	4	52	51	I	PA.F.INT	15	43	8	II	PA.F.INT	23	54	40	II	OC.F.EXT		
	4	56	41	I	PA.F.EXT	15	47	28	II	PA.F.EXT							
	19	58	41	III	EC.D.PEN	16	11	5	III	PA.F.INT	15	16	29	26	I	OM.D.EXT	
	20	3	33	III	EC.D.EXT	16	28	26	III	PA.F.EXT	16	33	15	I	OM.D.INT		
	20	19	22	III	EC.D.INT	10	9	4	10	I	OM.D.EXT	17	39	5	I	PA.D.EXT	
	21	43	45	II	OM.D.EXT	9	7	59	I	OM.D.INT	17	42	56	I	PA.D.INT		
	21	48	1	II	OM.D.INT	10	11	28	I	PA.D.EXT	18	39	42	I	OM.F.INT		
						10	15	18	I	PA.D.INT	18	43	31	I	OM.F.EXT		
						11	14	31	I	OM.F.INT	19	47	58	I	PA.F.INT		
											19	51	48	I	PA.F.EXT		

2006 - PHÉNOMÈNES DES SATELLITES GALILÉENS DE JUPITER
(Temps Terrestre)

JANVIER - DEUXIÈME QUINZAINE																			
jour	h	m	s	SAT.	TYPE	jour	h	m	s	SAT.	TYPE	jour	h	m	s	SAT.	TYPE		
16	13	32	57	II	OM.D.EXT	22	0	28	20	I	OC.F.INT	28	1	48	4	I	OM.D.EXT		
	13	37	14	II	OM.D.INT		2	8	34	I	OM.F.EXT		1	51	53	I	OM.D.INT		
	13	43	8	I	EC.D.PEN		3	14	48	I	PA.F.INT		3	1	28	I	PA.D.EXT		
	13	43	52	I	EC.D.EXT		3	18	39	I	PA.F.EXT		3	5	20	I	PA.D.INT		
	13	44	45	III	OM.D.EXT		21	7	43	I	EC.D.PEN		3	58	10	I	OM.F.INT		
	13	47	39	I	EC.D.INT		21	8	27	I	EC.D.EXT		4	1	59	I	OM.F.EXT		
	13	59	40	III	OM.D.INT		21	12	15	I	EC.D.INT		5	9	55	I	PA.F.INT		
	15	48	40	III	OM.F.INT		21	28	54	II	EC.D.PEN		5	13	46	I	PA.F.EXT		
	15	51	4	II	PA.D.EXT		21	30	31	II	EC.D.EXT		23	0	30	I	EC.D.PEN		
	15	55	26	II	PA.D.INT		21	34	55	II	EC.D.INT		23	1	15	I	EC.D.EXT		
	16	3	46	III	OM.F.EXT		23	15	35	56	I		EC.D.PEN	23	5	2	I	EC.D.INT	
	16	7	13	II	OM.F.INT			15	36	40	I		EC.D.EXT	29	0	4	39	II	EC.D.PEN
	16	11	30	II	OM.F.EXT			15	40	27	I		EC.D.INT	0	6	15	II	EC.D.EXT	
	17	1	59	I	OC.F.INT			16	5	44	II		OM.D.EXT	0	10	40	II	EC.D.INT	
	17	5	48	I	OC.F.EXT			16	10	0	II		OM.D.INT	2	22	44	I	OC.F.INT	
	18	21	32	II	PA.F.INT			16	17	6	III		OM.D.EXT	2	26	33	I	OC.F.EXT	
	18	25	53	II	PA.F.EXT			17	58	6	III		OM.D.INT	5	9	28	II	OC.F.INT	
	18	36	13	III	PA.D.EXT			18	28	37	II		PA.D.EXT	5	13	58	II	OC.F.EXT	
	18	54	26	III	PA.D.INT			18	33	1	II		PA.D.INT	20	16	30	I	OM.D.EXT	
	20	18	43	III	PA.F.INT			18	39	48	II		OM.F.INT	20	20	19	I	OM.D.INT	
20	36	44	III	PA.F.EXT	18	44		5	II	OM.F.EXT	21	30	13	I	PA.D.EXT				
17	10	57	45	I	OM.D.EXT	18		57	1	I	OC.F.INT	21	34	5	I	PA.D.INT			
	11	1	34	I	OM.D.INT	19		0	50	I	OC.F.EXT	22	26	34	I	OM.F.INT			
	12	8	6	I	PA.D.EXT	19		46	13	III	OM.F.INT	22	30	24	I	OM.F.EXT			
	12	11	56	I	PA.D.INT	20		1	26	III	OM.F.EXT	23	38	37	I	PA.F.INT			
	13	8	0	I	OM.F.INT	20		58	28	II	PA.F.INT	23	42	28	I	PA.F.EXT			
	13	11	49	I	OM.F.EXT	21		2	50	II	PA.F.EXT	30	17	28	43	I	EC.D.PEN		
	14	16	55	I	PA.F.INT	22		45	27	III	PA.D.EXT		17	29	27	I	EC.D.EXT		
	14	20	45	I	PA.F.EXT	23		4	26	III	PA.D.INT		17	33	14	I	EC.D.INT		
	18	8	11	20	I	EC.D.PEN		24	0	23	52		III	PA.F.INT	18	38	26	II	OM.D.EXT
		8	11	29	II	EC.D.PEN	0		42	37	III		PA.F.EXT	18	42	42	II	OM.D.INT	
8		12	4	I	EC.D.EXT	12	51		18	I	OM.D.EXT		20	51	11	I	OC.F.INT		
8		13	6	II	EC.D.EXT	12	55		7	I	OM.D.INT		20	55	1	I	OC.F.EXT		
8		15	52	I	EC.D.INT	14	3		54	I	PA.D.EXT		21	4	28	II	PA.D.EXT		
8		17	30	II	EC.D.INT	14	7		45	I	PA.D.INT		21	8	52	II	PA.D.INT		
11		30	50	I	OC.F.INT	15	1		26	I	OM.F.INT		21	12	21	II	OM.F.INT		
11		34	39	I	OC.F.EXT	15	5		16	I	OM.F.EXT	21	16	39	II	OM.F.EXT			
13		11	6	II	OC.F.INT	16	12		28	I	PA.F.INT	21	40	57	III	OM.D.EXT			
13		15	35	II	OC.F.EXT	16	16		18	I	PA.F.EXT	21	56	2	III	OM.D.INT			
19	5	26	12	I	OM.D.EXT	25	10	4	8	I	EC.D.PEN	23	33	44	II	PA.F.INT			
	5	30	1	I	OM.D.INT		10	4	52	I	EC.D.EXT	23	38	8	II	PA.F.EXT			
	6	37	10	I	PA.D.EXT		10	8	40	I	EC.D.INT	23	43	21	III	OM.F.INT			
	6	41	1	I	PA.D.INT		10	47	12	II	EC.D.PEN	23	48	1	III	OM.F.EXT			
	7	36	25	I	OM.F.INT		10	48	49	II	EC.D.EXT	31	2	50	34	III	PA.D.EXT		
	7	40	14	I	OM.F.EXT		10	53	14	II	EC.D.INT		3	10	23	III	PA.D.INT		
	8	45	56	I	PA.F.INT		13	25	39	I	OC.F.INT		4	24	52	III	PA.F.INT		
	8	49	46	I	PA.F.EXT		13	29	29	I	OC.F.EXT		4	44	26	III	PA.F.EXT		
	20	2	39	32	I		EC.D.PEN	15	50	44	II		OC.F.INT	14	44	48	I	OM.D.EXT	
		2	40	16	I		EC.D.EXT	15	55	13	II		OC.F.EXT	14	48	37	I	OM.D.INT	
2		44	3	I	EC.D.INT	26	7	19	44	I	OM.D.EXT		15	58	47	I	PA.D.EXT		
2		49	22	II	OM.D.EXT		7	23	33	I	OM.D.INT		16	2	39	I	PA.D.INT		
2		53	39	II	OM.D.INT		8	32	45	I	PA.D.EXT		16	54	51	I	OM.F.INT		
3		53	52	III	EC.D.PEN		8	36	37	I	PA.D.INT		16	58	41	I	OM.F.EXT		
3		58	47	III	EC.D.EXT		8	36	37	I	PA.D.INT	18	7	8	I	PA.F.INT			
4		14	49	III	EC.D.INT		9	29	51	I	OM.F.INT	18	10	59	I	PA.F.EXT			
5		10	4	II	PA.D.EXT		9	33	40	I	OM.F.EXT	27	4	32	19	I	EC.D.PEN		
5		14	27	II	PA.D.INT		10	41	16	I	PA.F.INT		4	33	3	I	EC.D.EXT		
5	23	33	II	OM.F.INT	10		45	6	I	PA.F.EXT	4		36	51	I	EC.D.INT			
5	27	50	II	OM.F.EXT	21		1	6	7	I	PA.D.EXT		5	22	6	II	OM.D.EXT		
5	53	37	III	EC.F.INT		1	9	58	I	PA.D.INT									
5	59	36	I	OC.F.INT															
6	3	25	I	OC.F.EXT															
6	9	39	III	EC.F.EXT															
6	14	34	III	EC.F.PEN															
7	40	14	II	PA.F.INT															
7	44	36	II	PA.F.EXT															
8	50	32	III	OC.D.EXT															
9	8	43	III	OC.D.INT															

2006 – CONFIGURATIONS DES SATELLITES GALILÉENS DE JUPITER

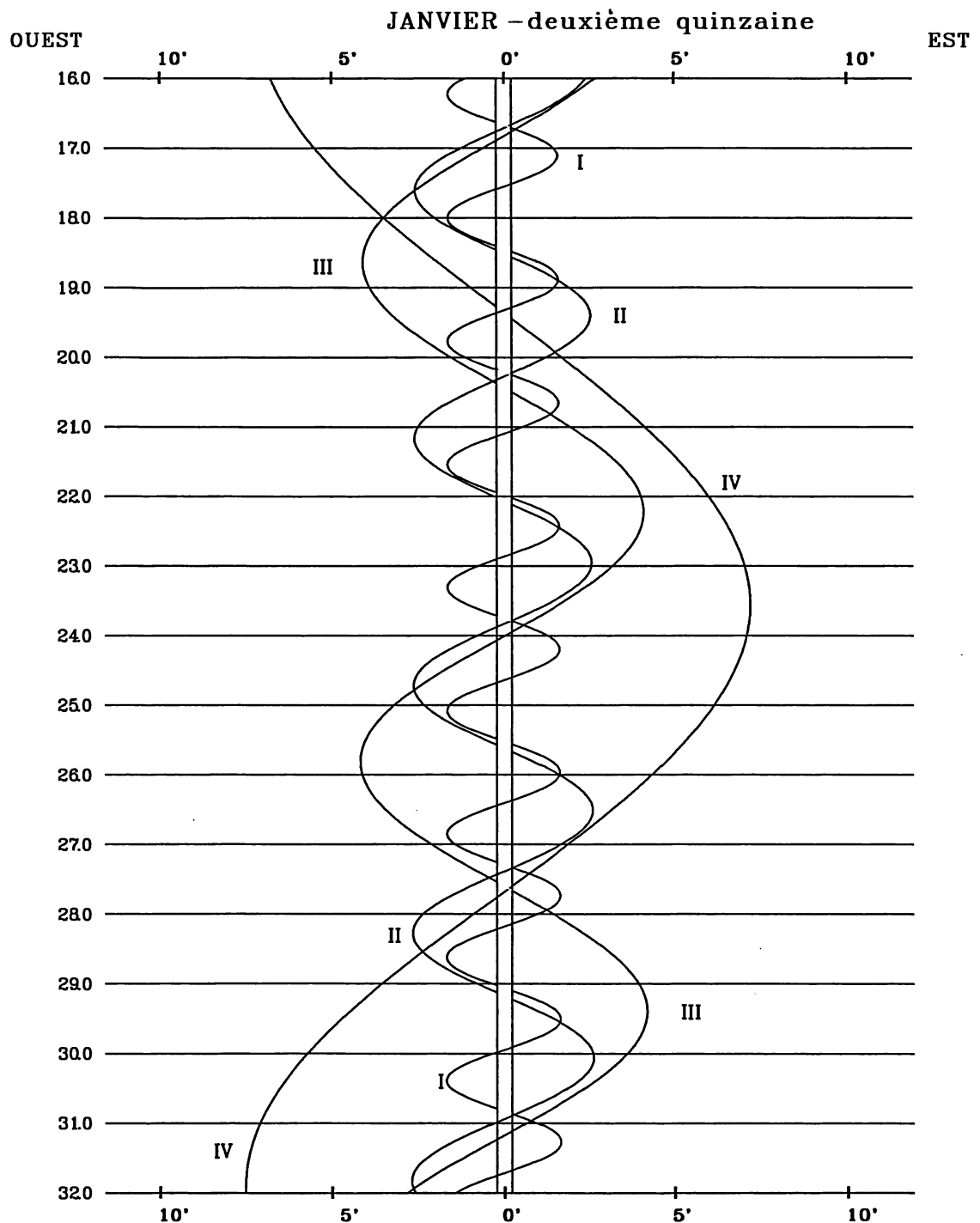

Dans le sens OUEST-EST, les satellites passent au-delà de Jupiter

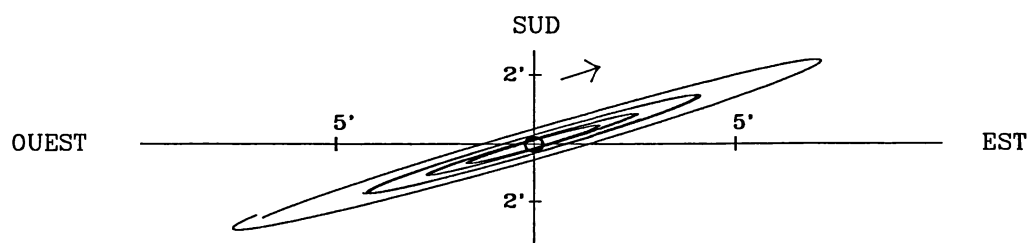

NORD
ORBITES APPARENTES

2006 - PHÉNOMÈNES DES SATELLITES GALILÉENS DE JUPITER
(Temps Terrestre)

FÉVRIER - PREMIÈRE QUINZAINE																			
jour	h	m	s	SAT.	TYPE	jour	h	m	s	SAT.	TYPE	jour	h	m	s	SAT.	TYPE		
1	11	56	55	I	EC.D.PEN	19	21	29	I	EC.D.PEN	22	28	13	III	OC.F.INT				
	11	57	39	I	EC.D.EXT		19	22	13	I		EC.D.EXT	22	48	49	III	OC.F.EXT		
	12	1	27	I	EC.D.INT		19	26	1	I		EC.D.INT							
	13	22	55	II	EC.D.PEN		21	11	9	II		OM.D.EXT	11	5	34	59	I	OM.D.EXT	
	13	24	32	II	EC.D.EXT		21	15	26	II		OM.D.INT		5	38	48	I	OM.D.INT	
	13	28	57	II	EC.D.INT		22	44	27	I		OC.F.INT		6	49	20	I	PA.D.EXT	
	15	19	37	I	OC.F.INT		22	48	17	I		OC.F.EXT		6	53	11	I	PA.D.INT	
	15	23	26	I	OC.F.EXT		23	38	33	II		PA.D.EXT		7	44	57	I	OM.F.INT	
	18	28	32	II	OC.F.INT		23	42	58	II		PA.D.INT		7	48	47	I	OM.F.EXT	
	18	33	2	II	OC.F.EXT		23	44	59	II		OM.F.INT		8	57	22	I	PA.F.INT	
					23	49	16	II	OM.F.EXT	9	1	13		I	PA.F.EXT				
2	9	13	13	I	OM.D.EXT	7	1	39	15	III	OM.D.EXT	12		2	46	4	I	EC.D.PEN	
	9	17	2	I	OM.D.INT		1	54	24	III	OM.D.INT			2	46	48	I	EC.D.EXT	
	10	27	25	I	PA.D.EXT		2	7	17	II	PA.F.INT		2	50	36	I	EC.D.INT		
	10	31	16	I	PA.D.INT		2	11	42	II	PA.F.EXT		5	15	58	II	EC.D.PEN		
	11	23	15	I	OM.F.INT		3	41	1	III	OM.F.INT		5	17	34	II	EC.D.EXT		
	11	27	5	I	OM.F.EXT		3	56	23	III	OM.F.EXT		5	21	59	II	EC.D.INT		
	12	35	42	I	PA.F.INT		6	52	10	III	PA.D.EXT		6	8	47	I	OC.F.INT		
	12	39	33	I	PA.F.EXT		7	12	53	III	PA.D.INT		6	12	37	I	OC.F.EXT		
	3	6	25	6	I		EC.D.PEN	8	22	24	III		PA.F.INT	13	10	20	59	II	OC.F.INT
		6	25	50	I		EC.D.EXT	8	42	50	III		PA.F.EXT		10	25	31	II	OC.F.EXT
6		29	38	I	EC.D.INT	16	38	15	I	OM.D.EXT									
7		54	47	II	OM.D.EXT	16	42	4	I	OM.D.INT	14	0	3		23	I	OM.D.EXT		
7		59	4	II	OM.D.INT	17	52	44	I	PA.D.EXT		0	7		12	I	OM.D.INT		
9		47	57	I	OC.F.INT	17	56	35	I	PA.D.INT		1	17		35	I	PA.D.EXT		
9		51	46	I	OC.F.EXT	18	48	15	I	OM.F.INT		1	21		27	I	PA.D.INT		
10		21	44	II	PA.D.EXT	18	52	5	I	OM.F.EXT		2	13		22	I	OM.F.INT		
10		26	9	II	PA.D.INT	20	0	52	I	PA.F.INT		2	17		11	I	OM.F.EXT		
10		28	40	II	OM.F.INT	20	4	43	I	PA.F.EXT		3	25		35	I	PA.F.INT		
10	32	58	II	OM.F.EXT	8	13	49	42	I	EC.D.PEN		3	29	26	I	PA.F.EXT			
11	47	36	III	EC.D.PEN		13	50	26	I	EC.D.EXT		21	14	16	I	EC.D.PEN			
11	52	33	III	EC.D.EXT		13	54	13	I	EC.D.INT		21	15	0	I	EC.D.EXT			
12	8	48	III	EC.D.INT		15	58	34	II	EC.D.PEN	21	18	48	I	EC.D.INT				
12	50	45	II	PA.F.INT		16	0	11	II	EC.D.EXT	23	43	51	II	OM.D.EXT				
12	55	9	II	PA.F.EXT		16	4	36	II	EC.D.INT	23	48	8	II	OM.D.INT				
13	45	57	III	EC.F.INT		17	12	39	I	OC.F.INT									
14	2	12	III	EC.F.EXT		17	16	28	I	OC.F.EXT	14	0	36	46	I	OC.F.INT			
14	7	9	III	EC.F.PEN		21	4	17	II	OC.F.INT		0	40	36	I	OC.F.EXT			
16	58	38	III	OC.D.EXT		21	4	17	II	OC.F.INT		2	10	42	II	PA.D.EXT			
17	18	21	III	OC.D.INT	21	8	49	II	OC.F.EXT	2		15	8	II	PA.D.INT				
18	33	47	III	OC.F.INT	9	11	6	40	I	OM.D.EXT		2	17	37	II	OM.F.INT			
18	53	30	III	OC.F.EXT		11	10	29	I	OM.D.INT		2	21	55	II	OM.F.EXT			
4	3	41	33	I		OM.D.EXT	12	21	6	I		PA.D.EXT	4	38	59	II	PA.F.INT		
	3	45	22	I		OM.D.INT	12	24	58	I		PA.D.INT	4	43	24	II	PA.F.EXT		
	4	55	54	I		PA.D.EXT	13	16	39	I		OM.F.INT	5	36	44	III	OM.D.EXT		
	4	59	45	I		PA.D.INT	13	20	28	I		OM.F.EXT	5	51	58	III	OM.D.INT		
	5	51	34	I		OM.F.INT	14	29	11	I	PA.F.INT	7	37	54	III	OM.F.INT			
	5	55	23	I		OM.F.EXT	14	33	2	I	PA.F.EXT	7	53	20	III	OM.F.EXT			
	7	4	7	I		PA.F.INT	10	8	17	52	I	EC.D.PEN	10	48	52	III	PA.D.EXT		
	7	7	58	I		PA.F.EXT		8	18	36	I	EC.D.EXT	11	10	34	III	PA.D.INT		
	5	0	53	17	I	EC.D.PEN		8	22	24	I	EC.D.INT	12	15	2	III	PA.F.INT		
		0	54	1	I	EC.D.EXT		10	27	31	II	OM.D.EXT	12	36	27	III	PA.F.EXT		
0		57	49	I	EC.D.INT	10		31	48	II	OM.D.INT	18	31	40	I	OM.D.EXT			
2		40	19	II	EC.D.PEN	11		40	44	I	OC.F.INT	18	35	29	I	OM.D.INT			
2		41	56	II	EC.D.EXT	11		44	34	I	OC.F.EXT	19	45	39	I	PA.D.EXT			
2		46	20	II	EC.D.INT	12		54	53	II	PA.D.EXT	19	49	31	I	PA.D.INT			
4		16	14	I	OC.F.INT	12		59	19	II	PA.D.INT	20	41	38	I	OM.F.INT			
4		20	3	I	OC.F.EXT	13		1	19	II	OM.F.INT	20	45	28	I	OM.F.EXT			
7		46	15	II	OC.F.INT	13	5	36	II	OM.F.EXT	21	53	37	I	PA.F.INT				
7		50	46	II	OC.F.EXT	15	23	23	II	PA.F.INT	21	57	28	I	PA.F.EXT				
22	9	58	I	OM.D.EXT	15	27	49	II	PA.F.EXT	15	15	42	29	I	EC.D.PEN				
22	13	47	I	OM.D.INT	15	44	37	III	EC.D.PEN		15	43	13	I	EC.D.EXT				
23	24	24	I	PA.D.EXT	15	49	36	III	EC.D.EXT		15	47	1	I	EC.D.INT				
23	28	16	I	PA.D.INT	16	5	57	III	EC.D.INT		18	34	14	II	EC.D.PEN				
6	0	19	58	I	OM.F.INT	16	5	57	III		EC.D.INT	18	35	50	II	EC.D.EXT			
	0	23	48	I	OM.F.EXT	17	42	18	III		EC.F.INT	18	40	15	II	EC.D.INT			
	1	32	35	I	PA.F.INT	17	58	39	III		EC.F.EXT	19	4	43	I	OC.F.INT			
	1	36	26	I	PA.F.EXT	18	3	38	III		EC.F.PEN	19	8	33	I	OC.F.EXT			
						20	57	5	III		OC.D.EXT	23	37	59	II	OC.F.INT			
						21	17	40	III		OC.D.INT	23	42	31	II	OC.F.EXT			

2006 – CONFIGURATIONS DES SATELLITES GALILÉENS DE JUPITER

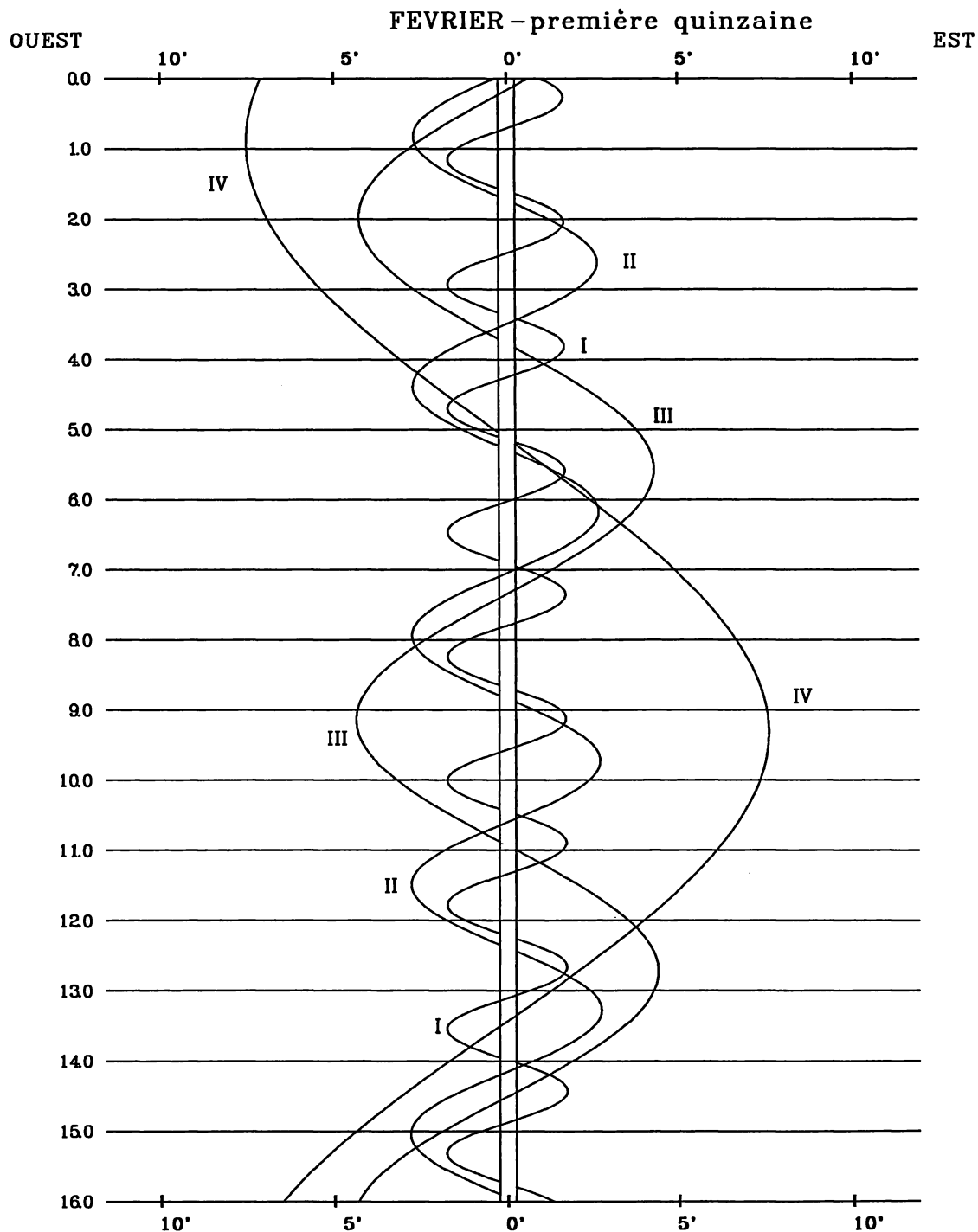

Dans le sens OUEST-EST, les satellites passent au-delà de Jupiter

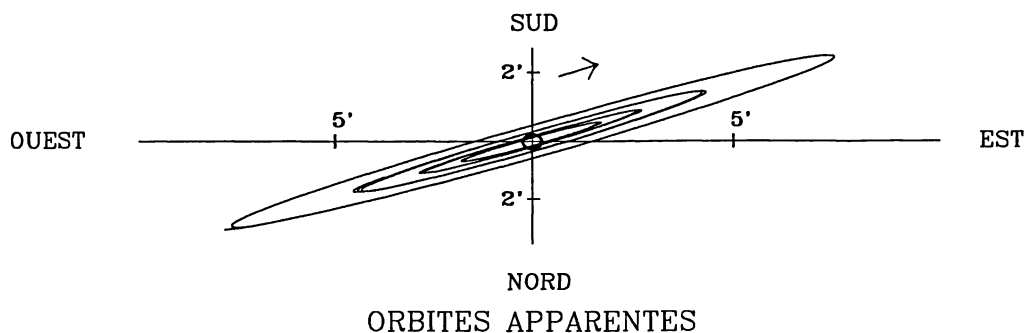

2006 – CONFIGURATIONS DES SATELLITES GALILÉENS DE JUPITER

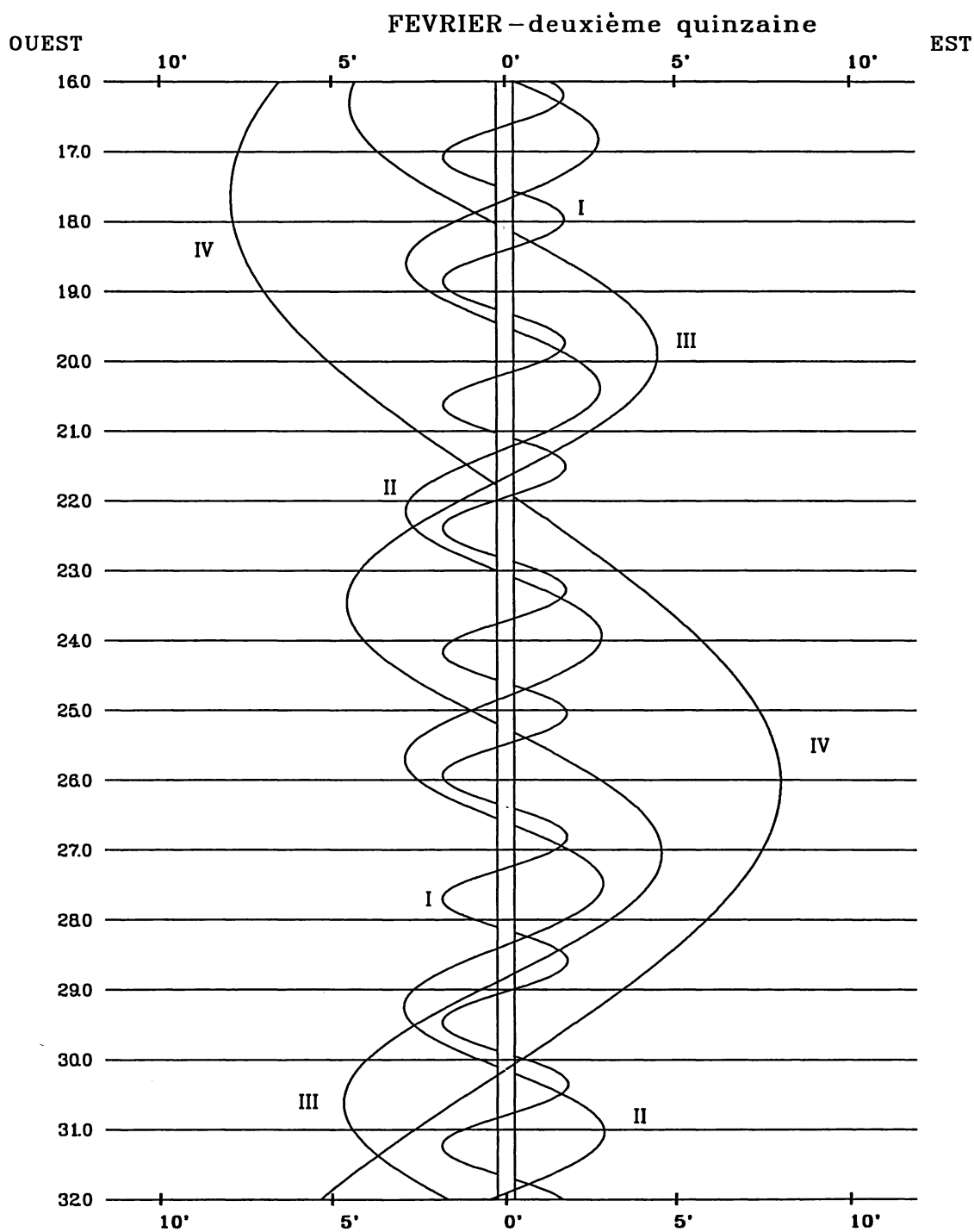

Dans le sens OUEST-EST, les satellites passent au-delà de Jupiter

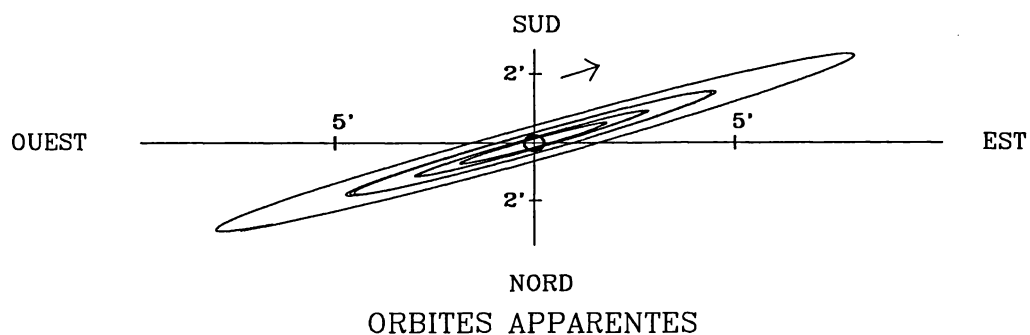

2006 - PHÉNOMÈNES DES SATELLITES GALILÉENS DE JUPITER
(Temps Terrestre)

MARS - PREMIÈRE QUINZAINE

jour	h	m	s	SAT.	TYPE	jour	h	m	s	SAT.	TYPE	jour	h	m	s	SAT.	TYPE
1	0	28	26	I	OM.F.INT		6	54	35	I	PA.D.INT	7	40	7	III	EC.D.EXT	
	0	32	15	I	OM.F.EXT		7	53	33	I	OM.F.INT	7	56	51	III	EC.D.INT	
	1	36	1	I	PA.F.INT		7	57	22	I	OM.F.EXT	9	30	16	III	EC.F.INT	
	1	39	53	I	PA.F.EXT		8	58	23	I	PA.F.INT	9	47	1	III	EC.F.EXT	
	19	28	9	I	EC.D.PEN		9	2	14	I	PA.F.EXT	9	52	5	III	EC.F.PEN	
	19	28	54	I	EC.D.EXT							12	8	27	III	OC.D.EXT	
	19	32	42	I	EC.D.INT	7	2	52	49	I	EC.D.PEN	12	33	0	III	OC.D.INT	
	22	45	49	I	OC.F.INT		2	53	33	I	EC.D.EXT	13	8	30	I	OM.D.EXT	
	22	49	40	I	OC.F.EXT		2	57	21	I	EC.D.INT	13	12	19	I	OM.D.INT	
	23	45	20	II	EC.D.PEN		6	7	38	I	OC.F.INT	13	24	53	III	OC.F.INT	
	23	46	57	II	EC.D.EXT		6	11	29	I	OC.F.EXT	13	49	27	III	OC.F.EXT	
	23	51	22	II	EC.D.INT		7	22	20	II	OM.D.EXT	14	12	23	I	PA.D.EXT	
2	4	38	36	II	OC.F.INT		7	26	38	II	OM.D.INT	14	16	16	I	PA.D.INT	
	4	43	10	II	OC.F.EXT		9	35	0	II	PA.D.EXT	15	18	34	I	OM.F.INT	
	16	46	49	I	OM.D.EXT		9	39	30	II	PA.D.INT	15	22	24	I	OM.F.EXT	
	16	50	38	I	OM.D.INT		9	56	13	II	OM.F.INT	16	20	2	I	PA.F.INT	
	17	55	51	I	PA.D.EXT		10	0	32	II	OM.F.EXT	16	23	54	I	PA.F.EXT	
	17	59	43	I	PA.D.INT		12	2	20	II	PA.F.INT						
	18	56	49	I	OM.F.INT		12	6	49	II	PA.F.EXT	12	10	17	33	I	EC.D.PEN
	19	0	39	I	OM.F.EXT		17	28	39	III	OM.D.EXT	10	18	17	I	EC.D.EXT	
	20	3	33	I	PA.F.INT		17	44	8	III	OM.D.INT	10	22	5	I	EC.D.INT	
	20	7	25	I	PA.F.EXT		19	28	15	III	OM.F.INT	13	28	55	I	OC.F.INT	
3	13	56	22	I	EC.D.PEN		19	43	56	III	OM.F.EXT	13	32	46	I	OC.F.EXT	
	13	57	6	I	EC.D.EXT		22	11	49	III	PA.D.EXT	15	38	12	II	EC.D.PEN	
	14	0	54	I	EC.D.INT		22	36	58	III	PA.D.INT	15	39	48	II	EC.D.EXT	
	17	13	9	I	OC.F.INT		23	26	19	III	PA.F.INT	15	44	13	II	EC.D.INT	
	17	16	59	I	OC.F.EXT		23	51	11	III	PA.F.EXT	20	17	46	II	OC.F.INT	
	18	5	53	II	OM.D.EXT	8	0	11	48	I	OM.D.EXT	20	22	20	II	OC.F.EXT	
	18	10	12	II	OM.D.INT		0	15	37	I	OM.D.INT	13	7	36	54	I	OM.D.EXT
	20	22	17	II	PA.D.EXT		1	17	58	I	PA.D.EXT	7	40	43	I	OM.D.INT	
	20	26	46	II	PA.D.INT		1	21	50	I	PA.D.INT	8	39	33	I	PA.D.EXT	
	20	39	44	II	OM.F.INT		2	21	51	I	OM.F.INT	8	43	26	I	PA.D.INT	
	20	44	3	II	OM.F.EXT		2	25	40	I	OM.F.EXT	9	47	0	I	OM.F.INT	
	22	49	43	II	PA.F.INT		3	25	37	I	PA.F.INT	9	50	49	I	OM.F.EXT	
	22	54	12	II	PA.F.EXT		3	29	29	I	PA.F.EXT	10	47	11	I	PA.F.INT	
4	3	37	50	III	EC.D.PEN		21	21	5	I	EC.D.PEN	10	51	4	I	PA.F.EXT	
	3	42	53	III	EC.D.EXT		21	21	49	I	EC.D.EXT	14	4	45	47	I	EC.D.PEN
	3	59	33	III	EC.D.INT		21	25	37	I	EC.D.INT	4	46	31	I	EC.D.EXT	
	5	33	38	III	EC.F.INT	9	0	34	49	I	OC.F.INT	4	50	20	I	EC.D.INT	
	5	50	17	III	EC.F.EXT		0	38	40	I	OC.F.EXT	7	55	52	I	OC.F.INT	
	5	55	20	III	EC.F.PEN		2	20	50	II	EC.D.PEN	7	59	43	I	OC.F.EXT	
	8	28	4	III	OC.D.EXT		2	22	26	II	EC.D.EXT	9	55	24	II	OM.D.EXT	
	8	51	37	III	OC.D.INT		2	26	51	II	EC.D.INT	9	59	43	II	OM.D.INT	
	9	47	47	III	OC.F.INT		7	5	29	II	OC.F.INT	11	58	57	II	PA.D.EXT	
	10	11	20	III	OC.F.EXT		7	10	3	II	OC.F.EXT	12	3	28	II	PA.D.INT	
	11	15	7	I	OM.D.EXT		18	40	11	I	OM.D.EXT	12	29	24	II	OM.F.INT	
	11	18	56	I	OM.D.INT		18	44	0	I	OM.D.INT	12	33	44	II	OM.F.EXT	
	12	23	16	I	PA.D.EXT		19	45	15	I	PA.D.EXT	14	26	8	II	PA.F.INT	
	12	27	8	I	PA.D.INT		19	49	7	I	PA.D.INT	14	30	37	II	PA.F.EXT	
	13	25	8	I	OM.F.INT		20	50	15	I	OM.F.INT	21	26	50	III	OM.D.EXT	
	13	28	58	I	OM.F.EXT		20	54	4	I	OM.F.EXT	21	42	26	III	OM.D.INT	
	14	30	57	I	PA.F.INT		21	52	54	I	PA.F.INT	23	26	0	III	OM.F.INT	
	14	34	49	I	PA.F.EXT		21	56	45	I	PA.F.EXT	23	41	45	III	OM.F.EXT	
5	8	24	35	I	EC.D.PEN	10	15	49	18	I	EC.D.PEN	15	1	50	59	III	PA.D.EXT
	8	25	20	I	EC.D.EXT		15	50	2	I	EC.D.EXT	2	5	11	I	OM.D.EXT	
	8	29	8	I	EC.D.INT		15	53	50	I	EC.D.INT	2	9	0	I	OM.D.INT	
	11	40	26	I	OC.F.INT		19	1	53	I	OC.F.INT	2	17	20	III	PA.D.INT	
	11	44	17	I	OC.F.EXT		19	5	44	I	OC.F.EXT	3	2	10	III	PA.F.INT	
	13	2	43	II	EC.D.PEN		20	38	53	II	OM.D.EXT	3	6	33	I	PA.D.EXT	
	13	4	19	II	EC.D.EXT		20	43	11	II	OM.D.INT	3	10	25	I	PA.D.INT	
	13	8	44	II	EC.D.INT		22	47	15	II	PA.D.EXT	3	28	15	III	PA.F.EXT	
	17	52	0	II	OC.F.INT		22	51	45	II	PA.D.INT	4	15	18	I	OM.F.INT	
	17	56	34	II	OC.F.EXT		23	12	49	II	OM.F.INT	4	19	7	I	OM.F.EXT	
6	5	43	31	I	OM.D.EXT	11	1	14	29	II	PA.F.INT	5	14	11	I	PA.F.INT	
	5	47	20	I	OM.D.INT		1	18	58	II	PA.F.EXT	5	18	3	I	PA.F.EXT	
	6	50	42	I	PA.D.EXT		7	35	3	III	EC.D.PEN	23	14	5	I	EC.D.PEN	
												23	14	49	I	EC.D.EXT	
												23	18	37	I	EC.D.INT	

2006 – CONFIGURATIONS DES SATELLITES GALILÉENS DE JUPITER

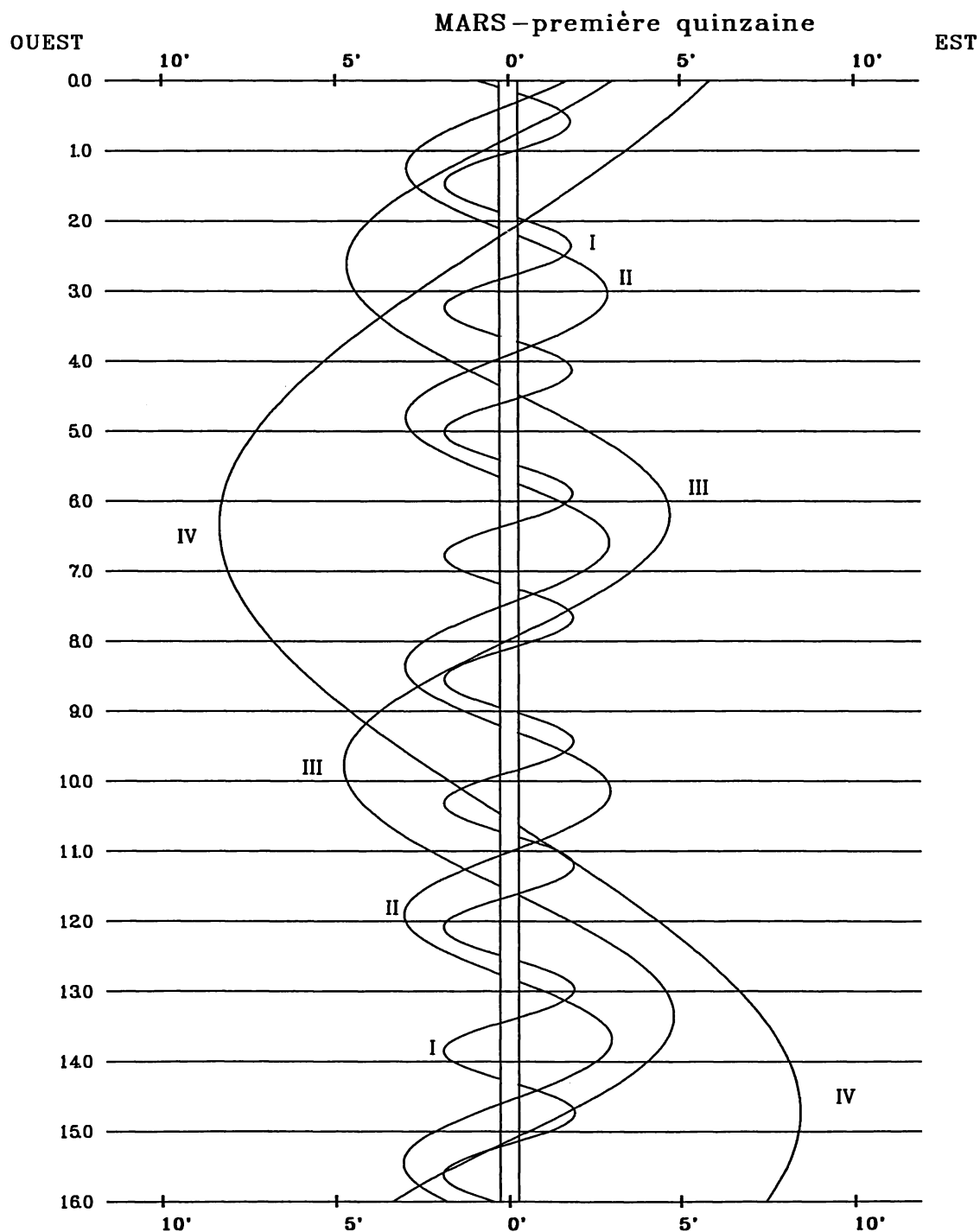

Dans le sens OUEST-EST, les satellites passent au-delà de Jupiter

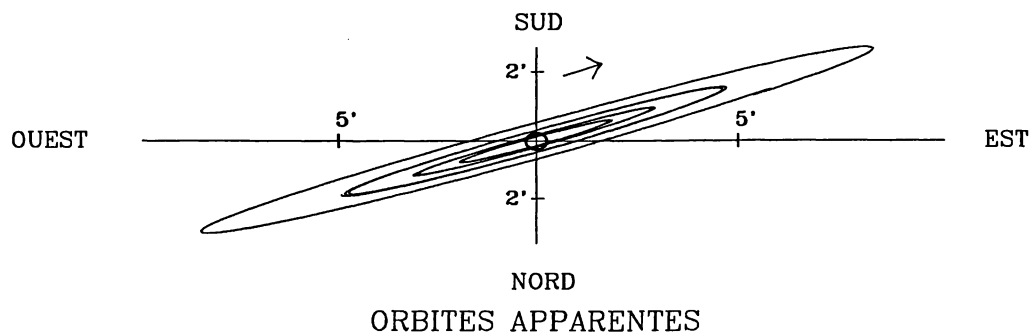

2006 - PHÉNOMÈNES DES SATELLITES GALILÉENS DE JUPITER
(Temps Terrestre)

MARS - DEUXIÈME QUINZAINE																	
jour	h	m	s	SAT.	TYPE	jour	h	m	s	SAT.	TYPE	jour	h	m	s	SAT.	TYPE
16	2	22	48	I	OC.F.INT		12	32	55	II	OM.D.INT	20	52	50	III	OC.F.EXT	
	2	26	39	I	OC.F.EXT		14	20	49	II	PA.D.EXT						
	4	56	16	II	EC.D.PEN		14	25	20	II	PA.D.INT	26	14	3	44	I	EC.D.PEN
	4	57	53	II	EC.D.EXT		15	2	45	II	OM.F.INT	14	14	4	29	I	EC.D.EXT
	5	2	18	II	EC.D.INT		15	7	5	II	OM.F.EXT	14	14	8	17	I	EC.D.INT
	9	30	5	II	OC.F.INT		16	47	56	II	PA.F.INT	17	17	2	58	I	OC.F.INT
	9	34	40	II	OC.F.EXT		16	52	27	II	PA.F.EXT	17	17	6	50	I	OC.F.EXT
	20	33	35	I	OM.D.EXT							20	20	49	5	II	EC.D.PEN
	20	37	24	I	OM.D.INT	22	1	24	35	III	OM.D.EXT	20	20	50	42	II	EC.D.EXT
	21	33	33	I	PA.D.EXT		1	40	16	III	OM.D.INT	20	20	55	7	II	EC.D.INT
	21	37	26	I	PA.D.INT		3	23	22	III	OM.F.INT						
	22	43	42	I	OM.F.INT		3	39	12	III	OM.F.EXT	27	1	2	44	II	OC.F.INT
	22	47	32	I	OM.F.EXT		3	58	36	I	OM.D.EXT	1	1	7	19	II	OC.F.EXT
	23	41	11	I	PA.F.INT		4	2	25	I	OM.D.INT	11	11	23	45	I	OM.D.EXT
	23	45	3	I	PA.F.EXT		4	54	4	I	PA.D.EXT	11	11	27	34	I	OM.D.INT
							4	57	57	I	PA.D.INT	12	12	14	7	I	PA.D.EXT
17	17	42	19	I	EC.D.PEN		5	24	56	III	PA.D.EXT	12	12	18	0	I	PA.D.INT
	17	43	4	I	EC.D.EXT		5	52	17	III	PA.D.INT	13	13	34	1	I	OM.F.INT
	17	46	52	I	EC.D.INT		6	8	48	I	OM.F.INT	13	13	37	50	I	OM.F.EXT
	20	49	37	I	OC.F.INT		6	12	37	I	OM.F.EXT	14	14	21	47	I	PA.F.INT
	20	53	29	I	OC.F.EXT		6	33	30	III	PA.F.INT	14	14	25	40	I	PA.F.EXT
	23	11	59	II	OM.D.EXT		7	0	38	III	PA.F.EXT						
	23	16	18	II	OM.D.INT		7	1	43	I	PA.F.INT	28	8	32	2	I	EC.D.PEN
							7	5	35	I	PA.F.EXT	8	8	32	46	I	EC.D.EXT
18	1	10	7	II	PA.D.EXT							8	8	36	34	I	EC.D.INT
	1	14	38	II	PA.D.INT	23	1	7	10	I	EC.D.PEN	11	11	29	27	I	OC.F.INT
	1	46	3	II	OM.F.INT		1	7	55	I	EC.D.EXT	11	11	33	18	I	OC.F.EXT
	1	50	23	II	OM.F.EXT		1	11	43	I	EC.D.INT	15	15	2	2	II	OM.D.EXT
	3	37	15	II	PA.F.INT		4	9	49	I	OC.F.INT	15	15	6	22	II	OM.D.INT
	3	41	45	II	PA.F.EXT		4	13	41	I	OC.F.EXT	16	16	40	47	II	PA.D.EXT
	11	32	7	III	EC.D.PEN		7	31	43	II	EC.D.PEN	16	16	45	19	II	PA.D.INT
	11	37	12	III	EC.D.EXT		7	33	20	II	EC.D.EXT	17	17	36	21	II	OM.F.INT
	11	54	1	III	EC.D.INT		7	37	44	II	EC.D.INT	17	17	40	41	II	OM.F.EXT
	13	26	47	III	EC.F.INT		11	52	34	II	OC.F.INT	19	19	7	56	II	PA.F.INT
	13	43	37	III	EC.F.EXT		11	57	8	II	OC.F.EXT	19	19	12	27	II	PA.F.EXT
	13	48	43	III	EC.F.PEN		22	27	0	I	OM.D.EXT						
	15	1	53	I	OM.D.EXT		22	30	49	I	OM.D.INT	29	5	22	52	III	OM.D.EXT
	15	5	43	I	OM.D.INT		23	20	50	I	PA.D.EXT	5	5	38	37	III	OM.D.INT
	15	43	58	III	OC.D.EXT		23	24	43	I	PA.D.INT	5	5	52	4	I	OM.D.EXT
	16	0	26	I	PA.D.EXT							5	5	55	53	I	OM.D.INT
	16	4	19	I	PA.D.INT	24	0	37	13	I	OM.F.INT	6	6	40	37	I	PA.D.EXT
	16	9	25	III	OC.D.INT		0	41	2	I	OM.F.EXT	6	6	44	30	I	PA.D.INT
	16	57	40	III	OC.F.INT		1	28	29	I	PA.F.INT	7	7	21	20	III	OM.F.INT
	17	12	3	I	OM.F.INT		1	32	21	I	PA.F.EXT	7	7	37	13	III	OM.F.EXT
	17	15	52	I	OM.F.EXT		19	35	26	I	EC.D.PEN	8	8	2	21	I	OM.F.INT
	17	23	8	III	OC.F.EXT		19	36	11	I	EC.D.EXT	8	8	6	10	I	OM.F.EXT
	18	8	4	I	PA.F.INT		19	39	59	I	EC.D.INT	8	8	48	18	I	PA.F.INT
	18	11	56	I	PA.F.EXT		22	36	25	I	OC.F.INT	8	8	52	10	I	PA.F.EXT
							22	40	16	I	OC.F.EXT	8	8	54	45	III	PA.D.EXT
19	12	10	36	I	EC.D.PEN							9	9	22	44	III	PA.D.INT
	12	11	20	I	EC.D.EXT	25	1	45	16	II	OM.D.EXT	10	10	1	44	III	PA.F.INT
	12	15	8	I	EC.D.INT		1	49	36	II	OM.D.INT	10	10	29	33	III	PA.F.EXT
	15	16	25	I	OC.F.INT		3	31	0	II	PA.D.EXT						
	15	20	16	I	OC.F.EXT		3	35	31	II	PA.D.INT	30	3	0	22	I	EC.D.PEN
	18	13	40	II	EC.D.PEN		4	19	29	II	OM.F.INT	3	3	1	7	I	EC.D.EXT
	18	15	17	II	EC.D.EXT		4	23	50	II	OM.F.EXT	3	3	4	55	I	EC.D.INT
	18	19	42	II	EC.D.INT		5	58	6	II	PA.F.INT	5	5	55	56	I	OC.F.INT
	22	41	19	II	OC.F.INT		6	2	37	II	PA.F.EXT	5	5	59	48	I	OC.F.EXT
	22	45	53	II	OC.F.EXT		15	29	16	III	EC.D.PEN	10	10	7	5	II	EC.D.PEN
20	9	30	18	I	OM.D.EXT		15	34	22	III	EC.D.EXT	10	10	8	42	II	EC.D.EXT
	9	34	7	I	OM.D.INT		15	51	18	III	EC.D.INT	10	10	13	6	II	EC.D.INT
	10	27	21	I	PA.D.EXT		16	55	20	I	OM.D.EXT	14	14	12	58	II	OC.F.INT
	10	31	13	I	PA.D.INT		16	59	9	I	OM.D.INT	14	14	17	32	II	OC.F.EXT
	11	40	28	I	OM.F.INT		17	23	23	III	EC.F.INT						
	11	44	18	I	OM.F.EXT		17	40	19	III	EC.F.EXT	31	0	20	28	I	OM.D.EXT
	12	34	59	I	PA.F.INT		17	45	25	III	EC.F.PEN	0	0	24	18	I	OM.D.INT
	12	38	51	I	PA.F.EXT		17	47	28	I	PA.D.EXT	1	1	7	8	I	PA.D.EXT
							17	51	20	I	PA.D.INT	1	1	11	1	I	PA.D.INT
							19	5	34	I	OM.F.INT	2	2	30	47	I	OM.F.INT
21	6	38	51	I	EC.D.PEN		19	9	23	I	OM.F.EXT	2	2	34	36	I	OM.F.EXT
	6	39	36	I	EC.D.EXT		19	15	3	III	OC.D.EXT	3	3	14	50	I	PA.F.INT
	6	43	24	I	EC.D.INT		19	41	16	III	OC.D.INT	3	3	18	42	I	PA.F.EXT
	9	43	7	I	OC.F.INT		19	55	7	I	PA.F.INT	21	21	28	40	I	EC.D.PEN
	9	46	58	I	OC.F.EXT		19	59	0	I	PA.F.EXT	21	21	29	25	I	EC.D.EXT
	12	28	36	II	OM.D.EXT		20	26	37	III	OC.F.INT	21	21	33	13	I	EC.D.INT

2006 – CONFIGURATIONS DES SATELLITES GALILÉENS DE JUPITER

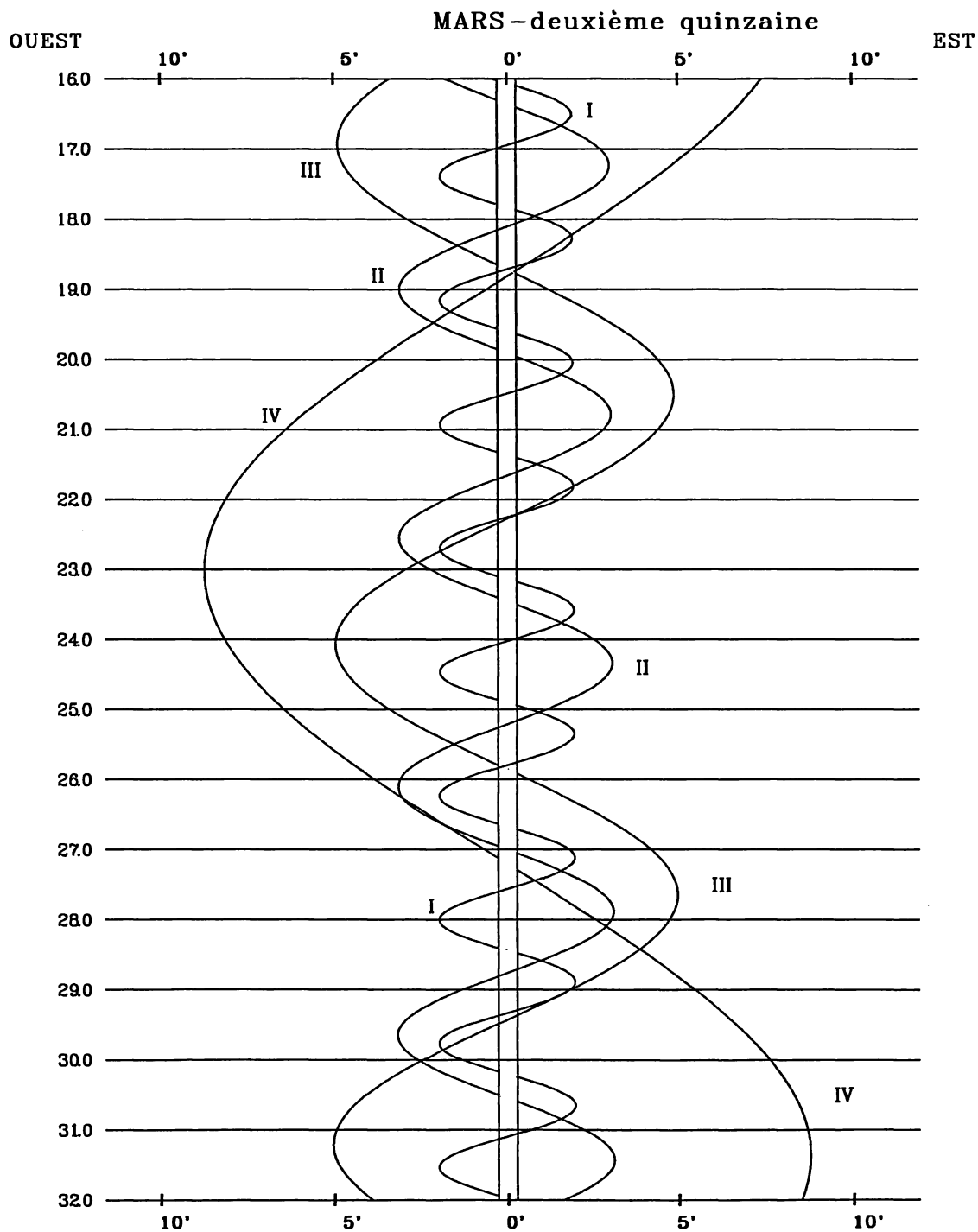

Dans le sens OUEST-EST, les satellites passent au-delà de Jupiter

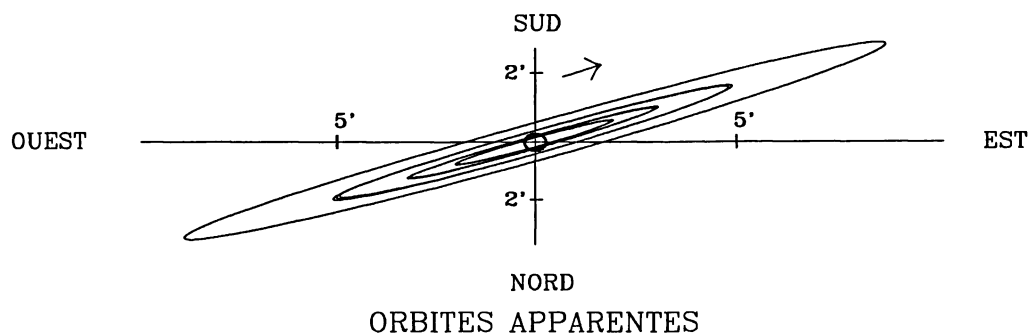

2006 - PHÉNOMÈNES DES SATELLITES GALILÉENS DE JUPITER
(Temps Terrestre)

AVRIL - PREMIÈRE QUINZAINE																	
jour	h	m	s	SAT.	TYPE	jour	h	m	s	SAT.	TYPE	jour	h	m	s	SAT.	TYPE
1	0	22	19	I	OC.F.INT	10	37	53	I	PA.F.EXT	17	25	6	I	OM.F.EXT		
	0	26	10	I	OC.F.EXT	11	18	36	III	OM.F.INT	17	52	52	I	PA.F.INT		
	4	18	47	II	OM.D.EXT	11	34	33	III	OM.F.EXT	17	56	44	I	PA.F.EXT		
	4	23	8	II	OM.D.INT	12	19	41	III	PA.D.EXT							
	5	50	2	II	PA.D.EXT	12	47	51	III	PA.D.INT	11	12	18	45	I	EC.D.PEN	
	5	54	34	II	PA.D.INT	13	26	13	III	PA.F.INT	12	19	29	I	EC.D.EXT		
	6	53	11	II	OM.F.INT	13	54	16	III	PA.F.EXT	12	12	23	18	I	EC.D.INT	
	6	57	32	II	OM.F.EXT						14	59	46	I	OC.F.INT		
	8	17	13	II	PA.F.INT	6	4	53	42	I	EC.D.PEN	15	3	38	I	OC.F.EXT	
	8	21	45	II	PA.F.EXT	4	54	27	I	EC.D.EXT	20	9	33	II	OM.D.EXT		
	18	48	49	I	OM.D.EXT	4	58	15	I	EC.D.INT	20	13	54	II	OM.D.INT		
	18	52	38	I	OM.D.INT	7	41	16	I	OC.F.INT	21	15	37	II	PA.D.EXT		
	19	26	43	III	EC.D.PEN	7	45	7	I	OC.F.EXT	21	20	9	II	PA.D.INT		
	19	31	50	III	EC.D.EXT	12	42	28	II	EC.D.PEN	22	44	13	II	OM.F.INT		
	19	33	33	I	PA.D.EXT	12	44	4	II	EC.D.EXT	22	48	34	II	OM.F.EXT		
	19	37	25	I	PA.D.INT	12	48	29	II	EC.D.INT	23	43	7	II	PA.F.INT		
	19	48	52	III	EC.D.INT	16	31	35	II	OC.F.INT	23	47	39	II	PA.F.EXT		
	20	59	9	I	OM.F.INT	16	36	9	II	OC.F.EXT							
	21	2	58	I	OM.F.EXT						12	9	39	13	I	OM.D.EXT	
	21	20	18	III	EC.F.INT	7	2	14	1	I	OM.D.EXT	9	43	2	I	OM.D.INT	
	21	37	19	III	EC.F.EXT	2	17	51	I	OM.D.INT	10	11	11	I	PA.D.EXT		
	21	41	15	I	PA.F.INT	2	52	35	I	PA.D.EXT	10	15	3	I	PA.D.INT		
	21	42	27	III	EC.F.PEN	2	56	28	I	PA.D.INT	11	49	40	I	OM.F.INT		
	21	45	8	I	PA.F.EXT	4	24	25	I	OM.F.INT	11	53	29	I	OM.F.EXT		
	22	42	1	III	OC.D.EXT	4	28	14	I	OM.F.EXT	12	19	1	I	PA.F.INT		
	23	8	40	III	OC.D.INT	5	0	21	I	PA.F.INT	12	22	53	I	PA.F.EXT		
	23	52	24	III	OC.F.INT	5	4	13	I	PA.F.EXT	13	17	58	III	OM.D.EXT		
						23	22	2	I	EC.D.PEN	13	33	53	III	OM.D.INT		
2	0	19	3	III	OC.F.EXT	23	22	46	I	EC.D.EXT	15	15	52	III	OM.F.INT		
	15	57	0	I	EC.D.PEN	23	26	35	I	EC.D.INT	15	31	51	III	OM.F.EXT		
	15	57	45	I	EC.D.EXT						15	40	53	III	PA.D.EXT		
	16	1	33	I	EC.D.INT	8	2	7	27	I	OC.F.INT	16	8	40	III	PA.D.INT	
	18	48	40	I	OC.F.INT	2	11	19	I	OC.F.EXT	16	48	18	III	PA.F.INT		
	18	52	32	I	OC.F.EXT	6	52	32	II	OM.D.EXT	17	16	1	III	PA.F.EXT		
	23	24	28	II	EC.D.PEN	6	56	52	II	OM.D.INT							
	23	26	5	II	EC.D.EXT	8	7	23	II	PA.D.EXT	13	6	47	10	I	EC.D.PEN	
	23	30	29	II	EC.D.INT	8	11	56	II	PA.D.INT	6	47	54	I	EC.D.EXT		
						9	27	5	II	OM.F.INT	6	51	43	I	EC.D.INT		
						9	31	26	II	OM.F.EXT	9	25	56	I	OC.F.INT		
3	3	22	13	II	OC.F.INT	10	34	45	II	PA.F.INT	9	29	48	I	OC.F.EXT		
	3	26	47	II	OC.F.EXT	10	39	17	II	PA.F.EXT	15	17	46	II	EC.D.PEN		
	13	17	16	I	OM.D.EXT	20	42	24	I	OM.D.EXT	15	19	23	II	EC.D.EXT		
	13	21	5	I	OM.D.INT	20	46	13	I	OM.D.INT	15	23	47	II	EC.D.INT		
	13	59	59	I	PA.D.EXT	21	18	48	I	PA.D.EXT	18	48	39	II	OC.F.INT		
	14	3	52	I	PA.D.INT	21	22	41	I	PA.D.INT	18	53	13	II	OC.F.EXT		
	15	27	37	I	OM.F.INT	22	52	48	I	OM.F.INT							
	15	31	26	I	OM.F.EXT	22	56	37	I	OM.F.EXT	14	4	7	40	I	OM.D.EXT	
	16	7	43	I	PA.F.INT	23	25	4	III	EC.D.PEN	4	11	29	I	OM.D.INT		
	16	11	35	I	PA.F.EXT	23	26	35	I	PA.F.INT	4	37	20	I	PA.D.EXT		
						23	30	13	III	EC.D.EXT	4	41	12	I	PA.D.INT		
4	10	25	19	I	EC.D.PEN	23	30	28	I	PA.F.EXT	6	18	8	I	OM.F.INT		
	10	26	4	I	EC.D.EXT	23	47	20	III	EC.D.INT	6	21	57	I	OM.F.EXT		
	10	29	52	I	EC.D.INT						6	45	11	I	PA.F.INT		
	13	14	57	I	OC.F.INT						6	49	3	I	PA.F.EXT		
	13	18	49	I	OC.F.EXT	9	1	18	7	III	EC.F.INT						
	17	35	39	II	OM.D.EXT	1	35	14	III	EC.F.EXT	15	1	15	32	I	EC.D.PEN	
	17	40	0	II	OM.D.INT	1	40	23	III	EC.F.PEN	1	16	16	I	EC.D.EXT		
	18	58	57	II	PA.D.EXT	17	50	24	I	EC.D.PEN	1	20	5	I	EC.D.INT		
	19	3	29	II	PA.D.INT	17	51	9	I	EC.D.EXT	3	52	0	I	OC.F.INT		
	20	10	9	II	OM.F.INT	17	54	57	I	EC.D.INT	3	55	52	I	OC.F.EXT		
	20	14	30	II	OM.F.EXT	20	33	39	I	OC.F.INT	9	26	35	II	OM.D.EXT		
	21	26	14	II	PA.F.INT	20	37	31	I	OC.F.EXT	9	30	56	II	OM.D.INT		
	21	30	45	II	PA.F.EXT						10	23	27	II	PA.D.EXT		
						10	1	59	51	II	EC.D.PEN	10	27	59	II	PA.D.INT	
5	7	45	36	I	OM.D.EXT	2	1	27	II	EC.D.EXT	12	1	18	II	OM.F.INT		
	7	49	25	I	OM.D.INT	2	5	52	II	EC.D.INT	12	5	39	II	OM.F.EXT		
	8	26	16	I	PA.D.EXT	5	40	3	II	OC.F.INT	12	51	5	II	PA.F.INT		
	8	30	9	I	PA.D.INT	5	44	37	II	OC.F.EXT	12	55	37	II	PA.F.EXT		
	9	20	26	III	OM.D.EXT	15	10	51	I	OM.D.EXT	22	36	4	I	OM.D.EXT		
	9	36	17	III	OM.D.INT	15	14	40	I	OM.D.INT	22	39	53	I	OM.D.INT		
	9	55	58	I	OM.F.INT	15	45	4	I	PA.D.EXT	23	3	24	I	PA.D.EXT		
	9	59	47	I	OM.F.EXT	15	48	56	I	PA.D.INT	23	7	16	I	PA.D.INT		
	10	34	1	I	PA.F.INT	17	21	17	I	OM.F.INT							

2006 – CONFIGURATIONS DES SATELLITES GALILÉENS DE JUPITER

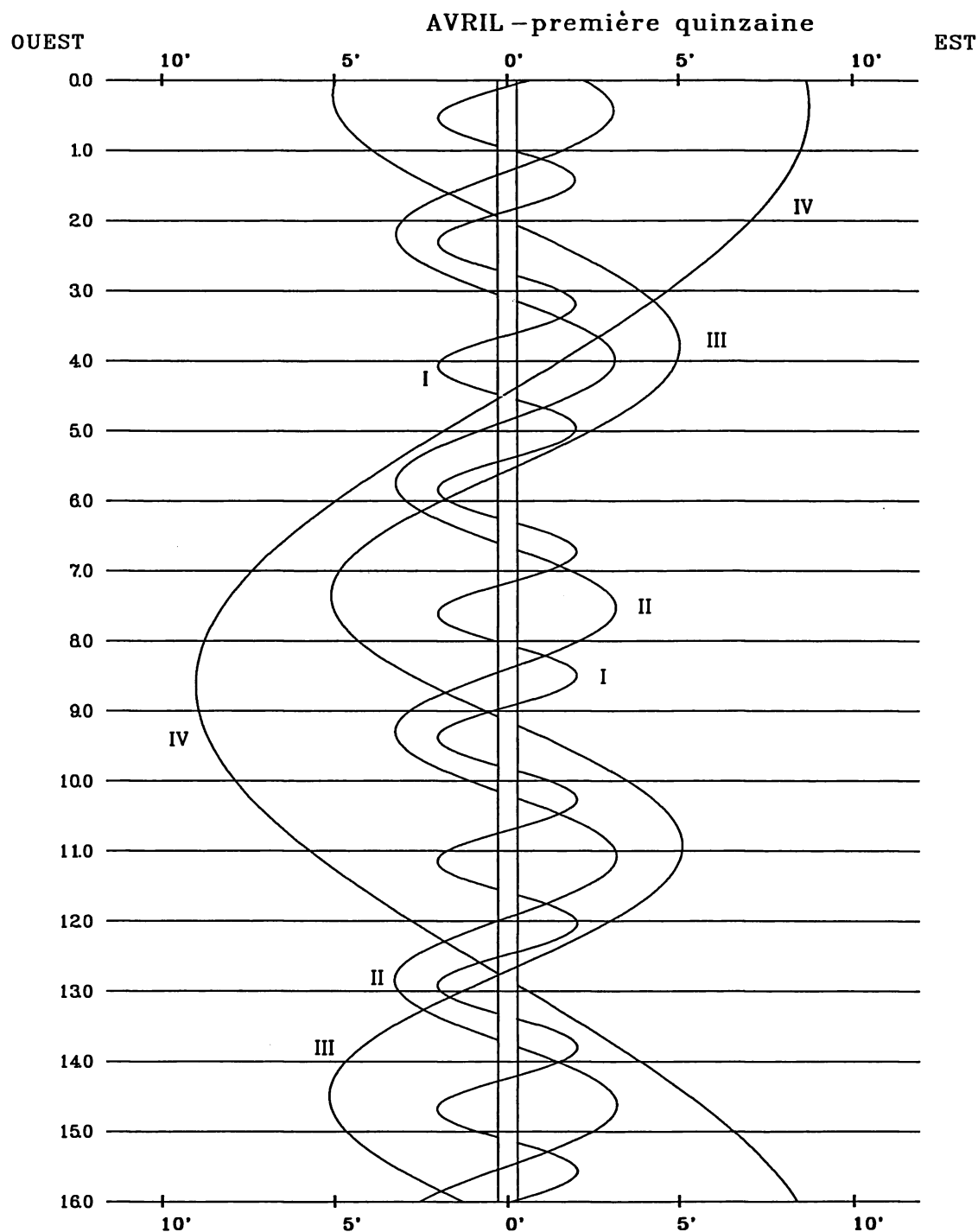

Dans le sens OUEST-EST, les satellites passent au-delà de Jupiter

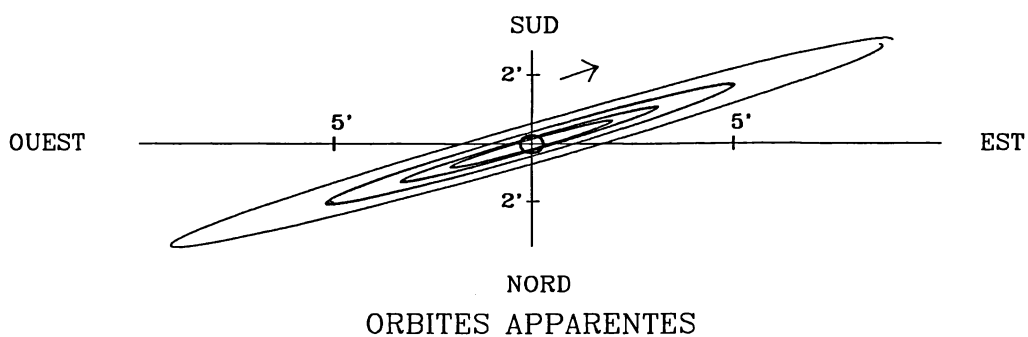

2006 – CONFIGURATIONS DES SATELLITES GALILÉENS DE JUPITER

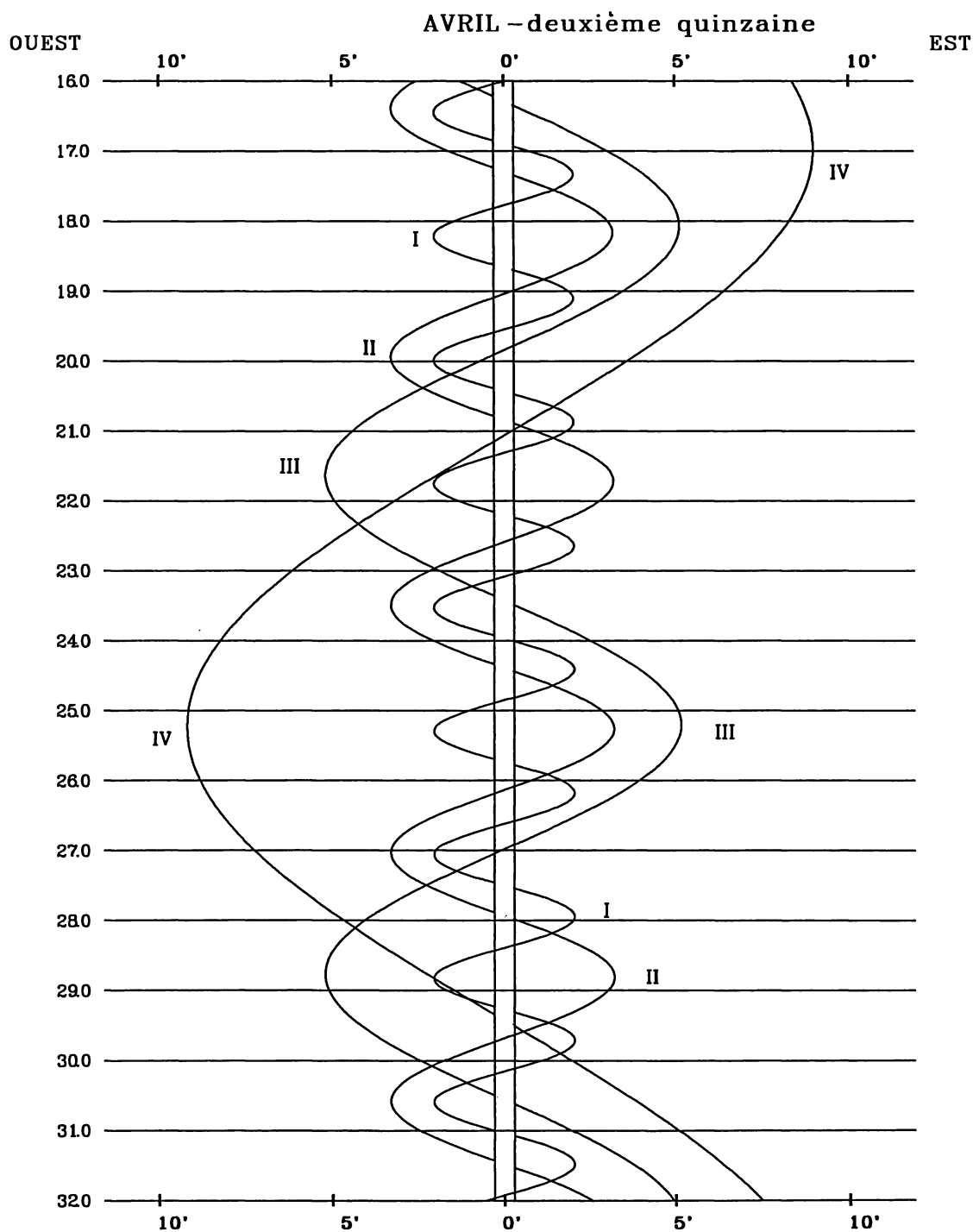

Dans le sens OUEST-EST, les satellites passent au-delà de Jupiter

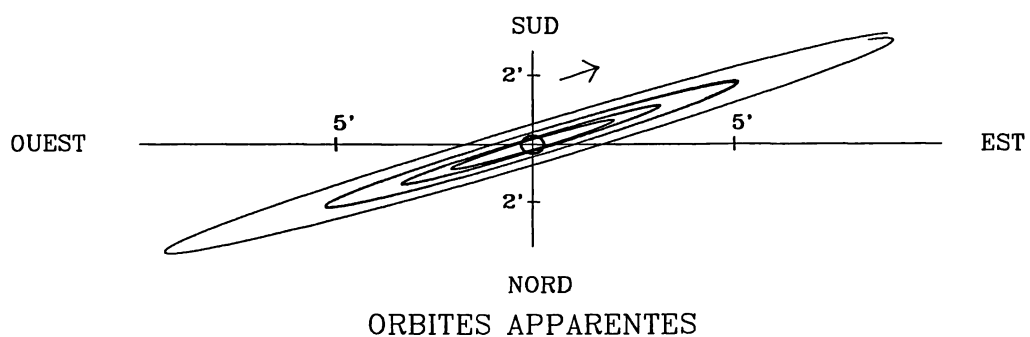

2006 - PHÉNOMÈNES DES SATELLITES GALILÉENS DE JUPITER
(Temps Terrestre)

MAI - PREMIÈRE QUINZAINE																		
jour	h	m	s	SAT.	TYPE	jour	h	m	s	SAT.	TYPE	jour	h	m	s	SAT.	TYPE	
1	1	45	57	I	OC.F.INT	9	6	48	I	EC.F.INT	11	4	46	13	III	PA.D.EXT		
	1	49	48	I	OC.F.EXT		9	10	37	I		EC.F.EXT	5	9	11	III	PA.D.INT	
	9	45	48	II	EC.D.PEN		9	11	21	I		EC.F.PEN	5	10	59	III	OM.D.EXT	
	9	47	24	II	EC.D.EXT		17	7	5	II		PA.D.EXT	5	27	12	III	OM.D.INT	
	9	51	48	II	EC.D.INT		17	10	31	II		OM.D.EXT	6	7	31	III	PA.F.INT	
	12	26	56	II	OC.F.INT		17	11	35	II		PA.D.INT	6	30	30	III	PA.F.EXT	
	12	31	28	II	OC.F.EXT		17	14	54	II		OM.D.INT	7	7	35	III	OM.F.INT	
	20	52	20	I	OM.D.EXT		19	36	0	II		PA.F.INT	7	23	45	III	OM.F.EXT	
	20	56	8	I	OM.D.INT		19	40	31	II		PA.F.EXT	14	13	24	I	OC.D.EXT	
	20	57	19	I	PA.D.EXT		19	45	30	II		OM.F.INT	14	17	15	I	OC.D.INT	
	21	1	11	I	PA.D.INT		19	49	52	II		OM.F.EXT	16	32	26	I	EC.F.INT	
	23	2	49	I	OM.F.INT		7	4	15	6		I	PA.D.EXT	16	36	15	I	EC.F.EXT
	23	5	25	I	PA.F.INT			4	17	49		I	OM.D.EXT	16	37	0	I	EC.F.PEN
	23	6	37	I	OM.F.EXT			4	18	57		I	PA.D.INT	12	1	19	44	II
23	9	17	I	PA.F.EXT	4	21		38	I	OM.D.INT	1	24	14		II	OC.D.INT		
2	17	59	55	I	EC.D.PEN	6		23	16	I	PA.F.INT	4	12		20	II	EC.F.INT	
	18	0	40	I	EC.D.EXT	6		27	8	I	PA.F.EXT	4	16		44	II	EC.F.EXT	
	18	4	29	I	EC.D.INT	6	28	16	I	OM.F.INT	4	18	20		II	EC.F.PEN		
	20	11	52	I	OC.F.INT	6	32	5	I	OM.F.EXT	11	33	4		I	PA.D.EXT		
	20	15	44	I	OC.F.EXT	15	14	13	III	OC.D.EXT	11	36	55	I	PA.D.INT			
	3	3	53	7	II	OM.D.EXT	15	37	6	III	OC.D.INT	11	43	27	I	OM.D.EXT		
3		57	29	II	OM.D.INT	17	9	2	III	EC.F.INT	11	47	16	I	OM.D.INT			
4		0	5	II	PA.D.EXT	17	26	26	III	EC.F.EXT	13	41	19	I	PA.F.INT			
4		4	36	II	PA.D.INT	17	31	38	III	EC.F.PEN	13	45	10	I	PA.F.EXT			
6		28	6	II	OM.F.INT	8	1	21	27	I	OC.D.EXT	13	53	50	I	OM.F.INT		
6		28	46	II	PA.F.INT		1	25	18	I	OC.D.INT	13	57	39	I	OM.F.EXT		
6		32	28	II	OM.F.EXT		3	35	20	I	EC.F.INT	13	8	39	22	I	OC.D.EXT	
6		33	17	II	PA.F.EXT		3	39	10	I	EC.F.EXT		8	43	13	I	OC.D.INT	
15		20	47	I	OM.D.EXT		3	39	54	I	EC.F.PEN		11	0	57	I	EC.F.INT	
15		23	13	I	PA.D.EXT		12	12	19	II	OC.D.EXT		11	4	47	I	EC.F.EXT	
15		24	36	I	OM.D.INT		12	16	50	II	OC.D.INT		11	5	31	I	EC.F.PEN	
15		27	4	I	PA.D.INT		14	54	41	II	EC.F.INT		19	21	38	II	PA.D.EXT	
17		31	16	I	OM.F.INT		14	59	5	II	EC.F.EXT		19	26	8	II	PA.D.INT	
17		31	20	I	PA.F.INT		15	0	41	II	EC.F.PEN		19	45	47	II	OM.D.EXT	
17	35	5	I	OM.F.EXT	22		41	6	I	PA.D.EXT	19		50	10	II	OM.D.INT		
17	35	12	I	PA.F.EXT	22		44	58	I	PA.D.INT	21		51	6	II	PA.F.INT		
4	1	12	22	III	OM.D.EXT		22	46	24	I	OM.D.EXT		21	55	37	II	PA.F.EXT	
	1	28	30	III	OM.D.INT		22	50	13	I	OM.D.INT		22	20	45	II	OM.F.INT	
	3	9	25	III	OM.F.INT	9	0	49	18	I	PA.F.INT		22	25	8	II	OM.F.EXT	
	3	25	33	III	OM.F.EXT		0	53	10	I	PA.F.EXT		14	5	59	4	I	PA.D.EXT
	12	28	28	I	EC.D.PEN		0	56	50	I	OM.F.INT	6		2	55	I	PA.D.INT	
	12	29	12	I	EC.D.EXT		1	0	38	I	OM.F.EXT	6		11	58	I	OM.D.EXT	
	12	33	1	I	EC.D.INT		19	47	22	I	OC.D.EXT	6		15	47	I	OM.D.INT	
	14	38	18	I	EC.F.INT		19	51	14	I	OC.D.INT	8		7	20	I	PA.F.INT	
	14	42	7	I	EC.F.EXT		22	3	50	I	EC.F.INT	8		11	11	I	PA.F.EXT	
	14	42	52	I	EC.F.PEN		22	7	39	I	EC.F.EXT	8		22	20	I	OM.F.INT	
	23	3	35	II	EC.D.PEN		22	8	24	I	EC.F.PEN	8		26	8	I	OM.F.EXT	
	23	5	11	II	EC.D.EXT		10	6	14	26	II	PA.D.EXT		18	29	10	III	OC.D.EXT
	23	9	35	II	EC.D.INT			6	18	56	II	PA.D.INT		18	50	50	III	OC.D.INT
	5	1	37	16	II			EC.F.INT	6	28	16	II		OM.D.EXT	21	6	43	III
1		41	40	II	EC.F.EXT			6	32	39	II	OM.D.INT		21	24	12	III	EC.F.EXT
1		43	16	II	EC.F.PEN			8	43	38	II	PA.F.INT		21	29	25	III	EC.F.PEN
9		49	10	I	PA.D.EXT	8		48	9	II	PA.F.EXT	15		3	5	24	I	OC.D.EXT
9		49	20	I	OM.D.EXT	9	3	16	II	OM.F.INT	3		9	16	I	OC.D.INT		
9		53	2	I	PA.D.INT	9	7	39	II	OM.F.EXT	5		29	33	I	EC.F.INT		
9		53	9	I	OM.D.INT	17	7	3	I	PA.D.EXT	5		33	22	I	EC.F.EXT		
11		57	20	I	PA.F.INT	17	10	54	I	PA.D.INT	5		34	7	I	EC.F.PEN		
11		59	47	I	OM.F.INT	17	14	54	I	OM.D.EXT	14		26	58	II	OC.D.EXT		
12		1	11	I	PA.F.EXT	17	18	42	I	OM.D.INT	14		31	28	II	OC.D.INT		
12		3	36	I	OM.F.EXT	19	15	17	I	PA.F.INT	17		29	45	II	EC.F.INT		
6		6	55	29	I	OC.D.EXT	19	19	8	I	PA.F.EXT		17	34	9	II	EC.F.EXT	
	6	59	21	I	OC.D.INT	19	25	18	I	OM.F.INT	17		35	44	II	EC.F.PEN		
						19	29	7	I	OM.F.EXT								

2006 - CONFIGURATIONS DES SATELLITES GALILÉENS DE JUPITER

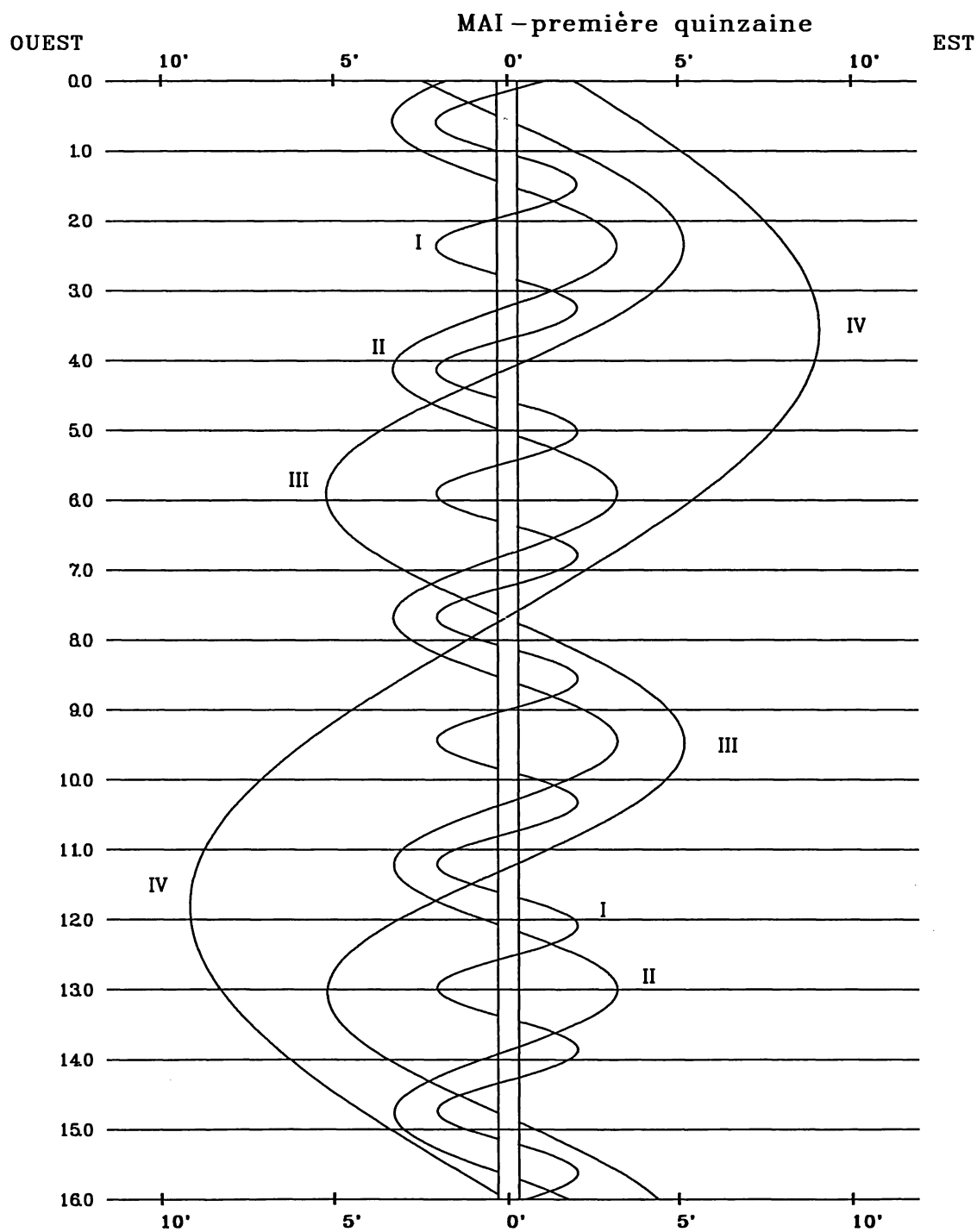

Dans le sens OUEST-EST, les satellites passent au-delà de Jupiter

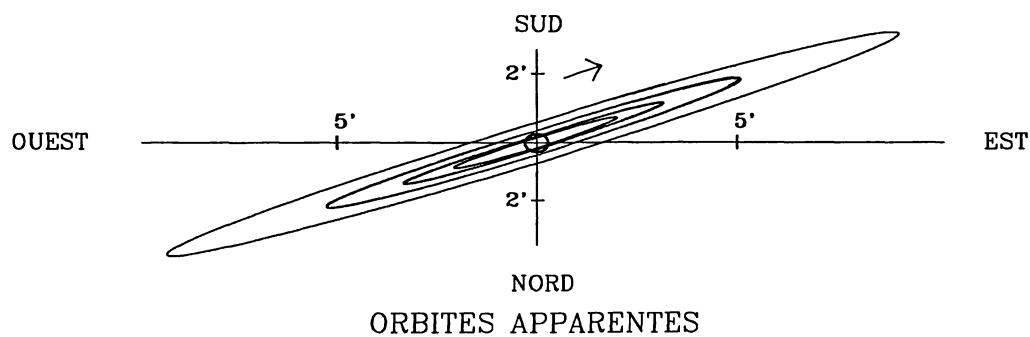

2006 - PHÉNOMÈNES DES SATELLITES GALILÉENS DE JUPITER
(Temps Terrestre)

MAI - DEUXIÈME QUINZAIN																	
jour	h	m	s	SAT.	TYPE	jour	h	m	s	SAT.	TYPE	jour	h	m	s	SAT.	TYPE
16	0	25	10	I	PA.D.EXT		9	51	48	I	PA.F.INT	17	10	33	I	PA.F.INT	
	0	29	1	I	PA.D.INT		9	55	39	I	PA.F.EXT	17	14	24	I	PA.F.EXT	
	0	40	34	I	OM.D.EXT		10	16	27	I	OM.F.INT	17	42	5	I	OM.F.INT	
	0	44	23	I	OM.D.INT		10	20	15	I	OM.F.EXT	17	45	54	I	OM.F.EXT	
	2	33	27	I	PA.F.INT		21	45	31	III	OC.D.EXT						
	2	37	18	I	PA.F.EXT		22	6	1	III	OC.D.INT	27	12	8	30	I	OC.D.EXT
	2	50	54	I	OM.F.INT		23	16	30	III	OC.F.INT	12	12	21	I	OC.D.INT	
	2	54	42	I	OM.F.EXT		23	19	21	III	EC.D.EXT	14	49	45	I	EC.F.INT	
	21	31	25	I	OC.D.EXT							14	53	35	I	EC.F.EXT	
	21	35	16	I	OC.D.INT	22	1	4	46	III	EC.F.INT	14	54	20	I	EC.F.PEN	
	23	58	4	I	EC.F.INT		1	22	19	III	EC.F.EXT	23	53	32	II	PA.D.EXT	
							1	27	33	III	EC.F.PEN	23	58	0	II	PA.D.INT	
17	0	1	54	I	EC.F.EXT		4	49	49	I	OC.D.EXT						
	0	2	39	I	EC.F.PEN		4	53	40	I	OC.D.INT	28	0	57	12	II	OM.D.EXT
	8	29	23	II	PA.D.EXT		7	23	54	I	EC.F.INT	1	1	36	II	OM.D.INT	
	8	33	53	II	PA.D.INT		7	27	44	I	EC.F.EXT	2	24	11	II	PA.F.INT	
	9	3	44	II	OM.D.EXT		7	28	29	I	EC.F.PEN	2	28	39	II	PA.F.EXT	
	9	8	8	II	OM.D.INT		16	42	17	II	OC.D.EXT	3	32	1	II	OM.F.INT	
	10	59	9	II	PA.F.INT		16	46	45	II	OC.D.INT	3	36	25	II	OM.F.EXT	
	11	3	39	II	PA.F.EXT		20	4	47	II	EC.F.INT	9	28	26	I	PA.D.EXT	
	11	38	42	II	OM.F.INT		20	9	10	II	EC.F.EXT	9	32	16	I	PA.D.INT	
	11	43	5	II	OM.F.EXT		20	10	46	II	EC.F.PEN	10	0	32	I	OM.D.EXT	
	18	51	12	I	PA.D.EXT							10	4	21	I	OM.D.INT	
	18	55	3	I	PA.D.INT	23	2	9	41	I	PA.D.EXT	11	36	52	I	PA.F.INT	
	19	9	6	I	OM.D.EXT		2	13	31	I	PA.D.INT	11	40	42	I	PA.F.EXT	
	19	12	54	I	OM.D.INT		2	34	50	I	OM.D.EXT	12	10	37	I	OM.F.INT	
	20	59	31	I	PA.F.INT		2	38	39	I	OM.D.INT	12	14	25	I	OM.F.EXT	
	21	3	22	I	PA.F.EXT		4	18	3	I	PA.F.INT						
	21	19	23	I	OM.F.INT		4	21	53	I	PA.F.EXT	29	1	4	43	III	OC.D.EXT
	21	23	12	I	OM.F.EXT		4	45	1	I	OM.F.INT	1	24	12	III	OC.D.INT	
							4	48	50	I	OM.F.EXT	2	40	32	III	OC.F.INT	
18	8	2	28	III	PA.D.EXT		23	15	58	I	OC.D.EXT	3	0	1	III	OC.F.EXT	
	8	24	3	III	PA.D.INT		23	19	49	I	OC.D.INT	3	13	27	III	EC.D.PEN	
	9	10	2	III	OM.D.EXT							3	18	43	III	EC.D.EXT	
	9	26	17	III	OM.D.INT	24	1	52	28	I	EC.F.INT	3	36	19	III	EC.D.INT	
	9	28	48	III	PA.F.INT		1	56	18	I	EC.F.EXT	5	3	46	III	EC.F.INT	
	9	50	24	III	PA.F.EXT		1	57	3	I	EC.F.PEN	5	21	23	III	EC.F.EXT	
	11	6	19	III	OM.F.INT		10	45	17	II	PA.D.EXT	5	26	38	III	EC.F.PEN	
	11	22	30	III	OM.F.EXT		10	49	46	II	PA.D.INT	6	34	51	I	OC.D.EXT	
	15	57	33	I	OC.D.EXT		11	39	27	II	OM.D.EXT	6	38	42	I	OC.D.INT	
	16	1	24	I	OC.D.INT		11	43	51	II	OM.D.INT	9	18	25	I	EC.F.INT	
	18	26	43	I	EC.F.INT		13	15	39	II	PA.F.INT	9	22	15	I	EC.F.EXT	
	18	30	32	I	EC.F.EXT		13	20	8	II	PA.F.EXT	9	23	0	I	EC.F.PEN	
	18	31	17	I	EC.F.PEN		14	14	21	II	OM.F.INT	18	58	42	II	OC.D.EXT	
							14	18	45	II	OM.F.EXT	19	3	8	II	OC.D.INT	
19	3	34	39	II	OC.D.EXT		20	35	52	I	PA.D.EXT	22	39	49	II	EC.F.INT	
	3	39	7	II	OC.D.INT		20	39	42	I	PA.D.INT	22	44	13	II	EC.F.EXT	
	6	47	21	II	EC.F.INT		21	3	23	I	OM.D.EXT	22	45	48	II	EC.F.PEN	
	6	51	45	II	EC.F.EXT		21	7	11	I	OM.D.INT						
	6	53	21	II	EC.F.PEN		22	44	15	I	PA.F.INT	30	3	54	51	I	PA.D.EXT
	13	17	20	I	PA.D.EXT		22	48	6	I	PA.F.EXT	3	58	41	I	PA.D.INT	
	13	21	10	I	PA.D.INT		23	13	32	I	OM.F.INT	4	29	11	I	OM.D.EXT	
	13	37	40	I	OM.D.EXT		23	17	20	I	OM.F.EXT	4	32	59	I	OM.D.INT	
	13	41	29	I	OM.D.INT							6	3	17	I	PA.F.INT	
	15	25	40	I	PA.F.INT	25	11	19	41	III	PA.D.EXT	6	7	7	I	PA.F.EXT	
	15	29	31	I	PA.F.EXT		11	40	0	III	PA.D.INT	6	39	12	I	OM.F.INT	
	15	47	56	I	OM.F.INT		12	51	4	III	PA.F.INT	6	43	1	I	OM.F.EXT	
	15	51	45	I	OM.F.EXT		13	8	25	III	OM.D.EXT						
20	10	23	38	I	OC.D.EXT		13	11	26	III	PA.F.EXT	31	1	1	11	I	OC.D.EXT
	10	27	29	I	OC.D.INT		13	24	42	III	OM.D.INT	1	5	2	I	OC.D.INT	
	12	55	17	I	EC.F.INT		15	4	22	III	OM.F.INT	3	47	1	I	EC.F.INT	
	12	59	6	I	EC.F.EXT		15	20	35	III	OM.F.EXT	3	50	51	I	EC.F.EXT	
	12	59	51	I	EC.F.PEN		17	42	15	I	OC.D.EXT	3	51	36	I	EC.F.PEN	
	21	37	0	II	PA.D.EXT		17	46	6	I	OC.D.INT	13	2	35	II	PA.D.EXT	
	21	41	30	II	PA.D.INT		20	21	9	I	EC.F.INT	13	7	3	II	PA.D.INT	
	22	21	22	II	OM.D.EXT		20	24	59	I	EC.F.EXT	14	15	27	II	OM.D.EXT	
	22	25	46	II	OM.D.INT		20	25	43	I	EC.F.PEN	14	19	51	II	OM.D.INT	
												15	33	33	II	PA.F.INT	
21	0	7	4	II	PA.F.INT	26	5	50	27	II	OC.D.EXT	15	38	1	II	PA.F.EXT	
	0	11	33	II	PA.F.EXT		5	54	54	II	OC.D.INT	16	50	14	II	OM.F.INT	
	0	56	17	II	OM.F.INT		9	22	23	II	EC.F.INT	16	54	39	II	OM.F.EXT	
	1	0	40	II	OM.F.EXT		9	26	47	II	EC.F.EXT	22	21	14	I	PA.D.EXT	
	7	43	27	I	PA.D.EXT		9	28	22	II	EC.F.PEN	22	25	4	I	PA.D.INT	
	7	47	17	I	PA.D.INT		15	2	9	I	PA.D.EXT	22	57	45	I	OM.D.EXT	
	8	6	13	I	OM.D.EXT		15	5	59	I	PA.D.INT	23	1	33	I	OM.D.INT	
	8	10	2	I	OM.D.INT		15	31	59	I	OM.D.EXT						
							15	35	47	I	OM.D.INT						

2006 - PHÉNOMÈNES DES SATELLITES GALILÉENS DE JUPITER
(Temps Terrestre)

JUN - PREMIÈRE QUINZAINE																	
jour	h	m	s	SAT.	TYPE	jour	h	m	s	SAT.	TYPE	jour	h	m	s	SAT.	TYPE
1	0	29	41	I	PA.F.INT							6	14	5	II	OM.D.INT	
	0	33	31	I	PA.F.EXT	6	1	14	48	II	EC.F.INT	7	7	26	II	PA.F.INT	
	1	7	44	I	OM.F.INT		1	19	11	II	EC.F.EXT	7	7	53	II	PA.F.EXT	
	1	11	32	I	OM.F.EXT		1	20	46	II	EC.F.PEN	8	44	15	II	OM.F.INT	
	14	39	19	III	PA.D.EXT		5	40	50	I	PA.D.EXT	8	48	40	II	OM.F.EXT	
	14	58	31	III	PA.D.INT		5	44	40	I	PA.D.INT	13	0	54	I	PA.D.EXT	
	16	15	41	III	PA.F.INT		6	23	36	I	OM.D.EXT	13	4	43	I	PA.D.INT	
	16	34	58	III	PA.F.EXT		6	27	24	I	OM.D.INT	13	49	25	I	OM.D.EXT	
	17	6	46	III	OM.D.EXT		7	49	19	I	PA.F.INT	13	53	13	I	OM.D.INT	
	17	23	5	III	OM.D.INT		7	53	9	I	PA.F.EXT	15	9	25	I	OM.F.INT	
	19	2	24	III	OM.F.INT		8	33	27	I	OM.F.INT	15	13	14	I	PA.F.EXT	
	19	18	37	III	OM.F.EXT		8	37	15	I	OM.F.EXT	15	59	8	I	OM.F.INT	
	19	27	41	I	OC.D.EXT							16	2	56	I	OM.F.EXT	
	19	31	31	I	OC.D.INT	7	2	47	17	I	OC.D.EXT	12	7	52	14	III	OC.D.EXT
	22	15	44	I	EC.F.INT		2	51	7	I	OC.D.INT	8	8	9	56	III	OC.D.INT
	22	19	34	I	EC.F.EXT		5	41	43	I	EC.F.INT	9	37	27	III	OC.F.INT	
	22	20	19	I	EC.F.PEN		5	45	32	I	EC.F.EXT	9	55	10	III	OC.F.EXT	
2	8	7	29	II	OC.D.EXT		5	46	17	I	EC.F.PEN	10	7	32	I	OC.D.EXT	
	8	11	55	II	OC.D.INT		15	21	37	II	PA.D.EXT	10	11	22	I	OC.D.INT	
	11	57	22	II	EC.F.INT		15	26	4	II	PA.D.INT	10	11	22	I	OC.D.INT	
	12	1	45	II	EC.F.EXT		16	51	43	II	OM.D.EXT	11	12	0	III	EC.D.PEN	
	12	3	20	II	EC.F.PEN		16	56	8	II	OM.D.INT	11	17	17	III	EC.D.EXT	
	16	47	43	I	PA.D.EXT		17	53	10	II	PA.F.INT	11	34	58	III	EC.D.INT	
	16	51	33	I	PA.D.INT		17	57	37	II	PA.F.EXT	13	1	50	III	EC.F.INT	
	17	26	22	I	OM.D.EXT		19	26	24	II	OM.F.INT	13	7	52	I	EC.F.INT	
	17	30	10	I	OM.D.INT		19	30	48	II	OM.F.EXT	13	11	42	I	EC.F.EXT	
	18	56	11	I	PA.F.INT	8	0	7	27	I	PA.D.EXT	13	12	27	I	EC.F.PEN	
	19	0	0	I	PA.F.EXT		0	11	16	I	PA.D.INT	13	19	32	III	EC.F.EXT	
	19	36	18	I	OM.F.INT		0	52	11	I	OM.D.EXT	13	24	48	III	EC.F.PEN	
	19	40	6	I	OM.F.EXT		0	56	0	I	OM.D.INT	23	36	3	II	OC.D.EXT	
3	13	54	8	I	OC.D.EXT		2	15	57	I	PA.F.INT	23	40	26	II	OC.D.INT	
	13	57	59	I	OC.D.INT		2	19	46	I	PA.F.EXT	13	3	49	47	II	EC.F.INT
	16	44	22	I	EC.F.INT		3	2	0	I	OM.F.INT	3	54	10	II	EC.F.EXT	
	16	48	12	I	EC.F.EXT		3	5	48	I	OM.F.EXT	3	55	45	II	EC.F.PEN	
	16	48	57	I	EC.F.PEN		18	2	13	III	PA.D.EXT	7	27	46	I	PA.D.EXT	
4	2	11	40	II	PA.D.EXT		18	20	28	III	PA.D.INT	7	31	35	I	PA.D.INT	
	2	16	7	II	PA.D.INT		19	43	16	III	PA.F.INT	8	18	5	I	OM.D.EXT	
	3	33	20	II	OM.D.EXT		20	1	37	III	PA.F.EXT	8	21	53	I	OM.D.INT	
	3	37	44	II	OM.D.INT		21	5	12	III	OM.D.EXT	9	36	17	I	PA.F.INT	
	4	42	54	II	PA.F.INT		21	14	0	I	OC.D.EXT	9	40	6	I	PA.F.EXT	
	4	47	22	II	PA.F.EXT		21	17	50	I	OC.D.INT	10	27	45	I	OM.F.INT	
	6	8	2	II	OM.F.INT		21	21	33	III	OM.D.INT	10	31	33	I	OM.F.EXT	
	6	12	26	II	OM.F.EXT		23	0	30	III	OM.F.INT	14	4	34	21	I	OC.D.EXT
	11	14	13	I	PA.D.EXT		23	16	43	III	OM.F.EXT	14	4	38	11	I	OC.D.INT
	11	18	2	I	PA.D.INT	9	0	10	28	I	EC.F.INT	7	36	32	I	EC.F.INT	
	11	54	57	I	OM.D.EXT		0	14	17	I	EC.F.EXT	7	40	22	I	EC.F.EXT	
	11	58	45	I	OM.D.INT		0	15	2	I	EC.F.PEN	7	41	7	I	EC.F.PEN	
	13	22	41	I	PA.F.INT		10	26	6	II	OC.D.EXT	17	42	37	II	PA.D.EXT	
	13	26	31	I	PA.F.EXT		10	30	31	II	OC.D.INT	17	47	2	II	PA.D.INT	
	14	4	51	I	OM.F.INT		14	32	19	II	EC.F.INT	19	28	13	II	OM.D.EXT	
	14	8	39	I	OM.F.EXT		14	36	42	II	EC.F.EXT	19	32	38	II	OM.D.INT	
5	4	26	24	III	OC.D.EXT		14	38	17	II	EC.F.PEN	20	14	44	II	PA.F.INT	
	4	44	56	III	OC.D.INT		18	34	10	I	PA.D.EXT	20	19	10	II	PA.F.EXT	
	6	7	1	III	OC.F.INT		18	37	59	I	PA.D.INT	22	2	45	II	OM.F.INT	
	6	25	33	III	OC.F.EXT		19	20	49	I	OM.D.EXT	22	7	10	II	OM.F.EXT	
	7	12	25	III	EC.D.PEN		19	24	37	I	OM.D.INT	15	1	54	37	I	PA.D.EXT
	7	17	41	III	EC.D.EXT		20	42	40	I	PA.F.INT	1	58	26	I	PA.D.INT	
	7	35	21	III	EC.D.INT		20	46	29	I	PA.F.EXT	2	46	41	I	OM.D.EXT	
	8	20	43	I	OC.D.EXT		21	30	35	I	OM.F.INT	2	50	30	I	OM.D.INT	
	8	24	33	I	OC.D.INT		21	34	23	I	OM.F.EXT	4	3	9	I	PA.F.INT	
	9	2	27	III	EC.F.INT	10	15	40	42	I	OC.D.EXT	4	6	58	I	PA.F.EXT	
	9	20	7	III	EC.F.EXT		15	44	32	I	OC.D.INT	4	56	19	I	OM.F.INT	
	9	25	23	III	EC.F.PEN		18	39	8	I	EC.F.INT	5	0	7	I	OM.F.EXT	
	11	13	5	I	EC.F.INT		18	42	57	I	EC.F.EXT	21	29	5	III	PA.D.EXT	
	11	16	55	I	EC.F.EXT		18	43	42	I	EC.F.PEN	21	46	30	III	PA.D.INT	
	11	17	39	I	EC.F.PEN	11	4	31	37	II	PA.D.EXT	23	1	20	I	OC.D.EXT	
	21	16	30	II	OC.D.EXT		4	36	3	II	PA.D.INT	23	5	9	I	OC.D.INT	
	21	20	55	II	OC.D.INT		6	9	40	II	OM.D.EXT	23	14	31	III	PA.F.INT	
												23	32	4	III	PA.F.EXT	

2006 - CONFIGURATIONS DES SATELLITES GALILÉENS DE JUPITER

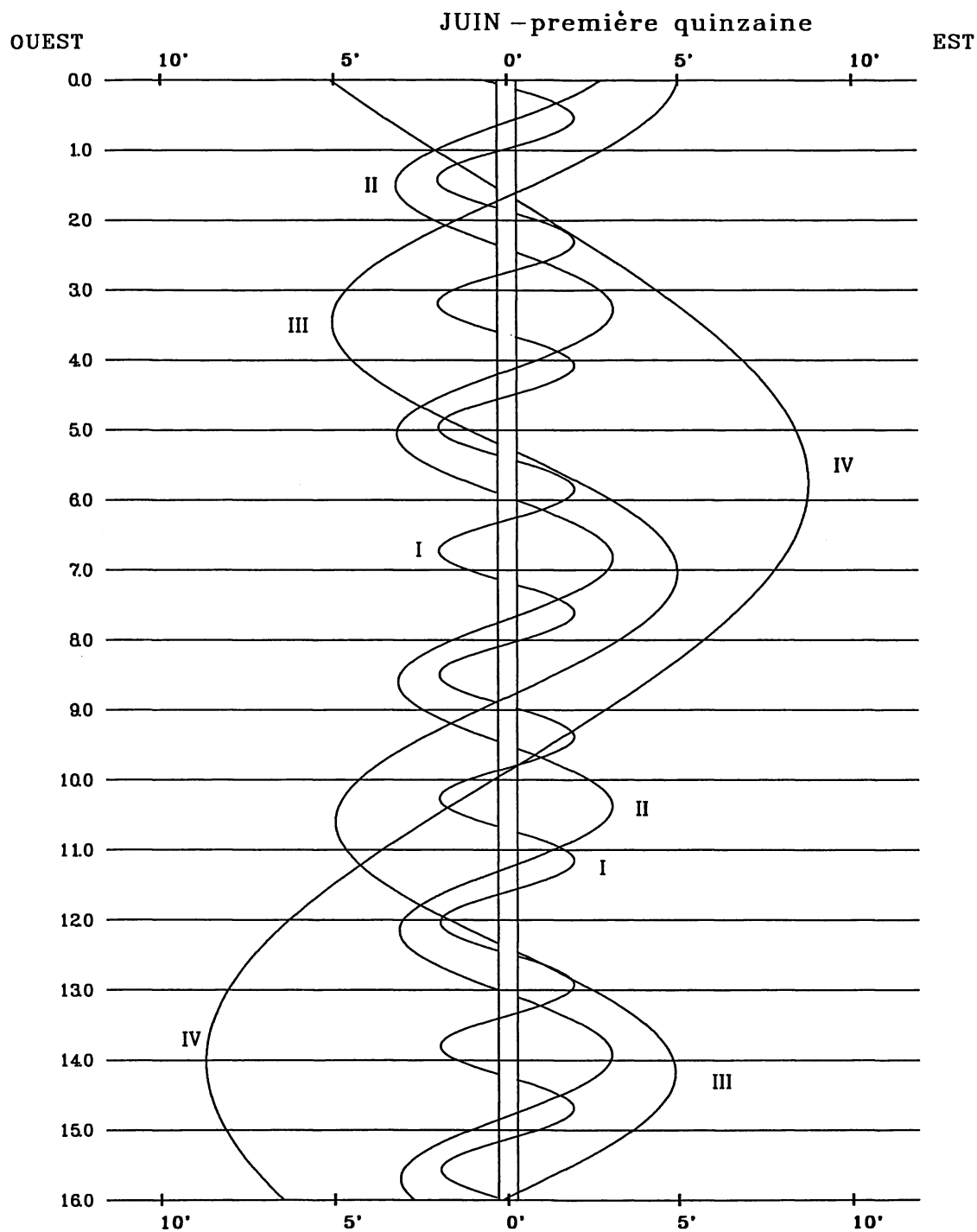

Dans le sens OUEST-EST, les satellites passent au-delà de Jupiter

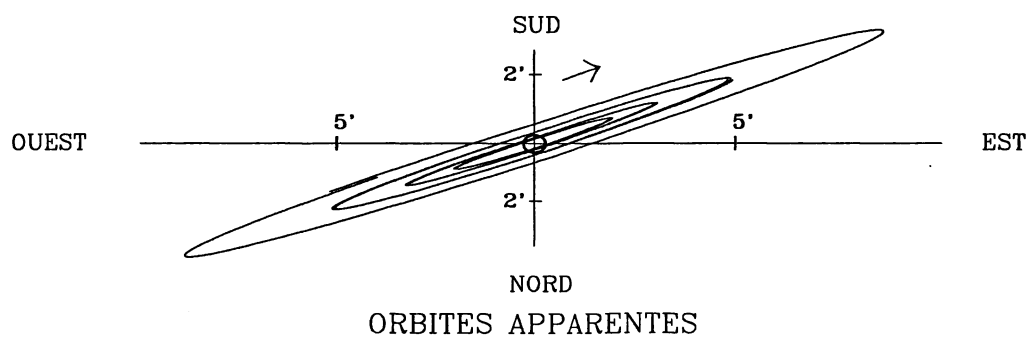

2006 - PHÉNOMÈNES DES SATELLITES GALILÉENS DE JUPITER
(Temps Terrestre)

JUIN - DEUXIÈME QUINZAINE																	
jour	h	m	s	SAT.	TYPE	jour	h	m	s	SAT.	TYPE	jour	h	m	s	SAT.	TYPE
16	1	3	52	III	OM.D.EXT												
	1	20	15	III	OM.D.INT	21	6	22	28	I	OC.D.EXT	26	13	44	22	I	OC.D.EXT
	2	5	19	I	EC.F.INT		6	26	18	I	OC.D.INT		13	48	11	I	OC.D.INT
	2	9	8	I	EC.F.EXT		9	31	28	I	EC.F.INT		14	54	27	III	OC.D.EXT
	2	9	53	I	EC.F.PEN		9	35	18	I	EC.F.EXT		15	10	52	III	OC.D.INT
	2	58	50	III	OM.F.INT		9	36	3	I	EC.F.PEN		16	47	52	III	OC.F.INT
	3	15	4	III	OM.F.EXT		20	5	48	II	PA.D.EXT		16	57	48	I	EC.F.INT
	12	46	32	II	OC.D.EXT		20	10	12	II	PA.D.INT		17	1	38	I	EC.F.EXT
	12	50	55	II	OC.D.INT		22	4	59	II	OM.D.EXT		17	2	23	I	EC.F.PEN
	17	7	15	II	EC.F.INT		22	9	24	II	OM.D.INT		17	4	17	III	OC.F.EXT
	17	11	38	II	EC.F.EXT		22	38	28	II	PA.F.INT		19	9	35	III	EC.D.PEN
	17	13	13	II	EC.F.PEN		22	42	53	II	PA.F.EXT		19	14	53	III	EC.D.EXT
	20	21	35	I	PA.D.EXT								19	32	38	III	EC.D.INT
	20	25	23	I	PA.D.INT	22	0	39	23	II	OM.F.INT		20	59	5	III	EC.F.INT
	21	15	20	I	OM.D.EXT		0	43	48	II	OM.F.EXT		21	16	50	III	EC.F.EXT
	21	19	8	I	OM.D.INT		3	42	49	I	PA.D.EXT		21	22	7	III	EC.F.PEN
	22	30	7	I	PA.F.INT		3	46	37	I	PA.D.INT						
	22	33	56	I	PA.F.EXT		4	41	15	I	OM.D.EXT	27	4	20	53	II	OC.D.EXT
	23	24	54	I	OM.F.INT		4	45	3	I	OM.D.INT		4	25	14	II	OC.D.INT
	23	28	42	I	OM.F.EXT		5	51	23	I	PA.F.INT		8	59	35	II	EC.F.INT
							5	55	12	I	PA.F.EXT		9	3	58	II	EC.F.EXT
17	17	28	18	I	OC.D.EXT		6	50	42	I	OM.F.INT		9	5	32	II	EC.F.PEN
	17	32	7	I	OC.D.INT		6	54	30	I	OM.F.EXT		11	4	41	I	PA.D.EXT
	20	34	0	I	EC.F.INT								11	8	29	I	PA.D.INT
	20	37	50	I	EC.F.EXT	23	0	49	44	I	OC.D.EXT		12	7	13	I	OM.D.EXT
	20	38	35	I	EC.F.PEN		0	53	34	I	OC.D.INT		12	11	1	I	OM.D.INT
							1	0	57	III	PA.D.EXT		13	13	17	I	PA.F.INT
18	6	53	40	II	PA.D.EXT		1	17	42	III	PA.D.INT		13	17	5	I	PA.F.EXT
	6	58	5	II	PA.D.INT		2	50	22	III	PA.F.INT		14	16	32	I	OM.F.INT
	8	46	16	II	OM.D.EXT		3	7	15	III	PA.F.EXT		14	20	20	I	OM.F.EXT
	8	50	41	II	OM.D.INT		4	0	16	I	EC.F.INT						
	9	26	2	II	PA.F.INT		4	4	6	I	EC.F.EXT	28	8	11	44	I	OC.D.EXT
	9	30	28	II	PA.F.EXT		4	4	51	I	EC.F.PEN		8	15	33	I	OC.D.INT
	11	20	43	II	OM.F.INT		5	3	26	III	OM.D.EXT		11	26	30	I	EC.F.INT
	11	25	8	II	OM.F.EXT		5	19	51	III	OM.D.INT		11	30	20	I	EC.F.EXT
	14	48	34	I	PA.D.EXT		6	58	7	III	OM.F.INT		11	31	5	I	EC.F.PEN
	14	52	23	I	PA.D.INT		7	14	22	III	OM.F.EXT		22	31	13	II	PA.D.EXT
	15	43	57	I	OM.D.EXT		15	8	54	II	OC.D.EXT		22	35	37	II	PA.D.INT
	15	47	45	I	OM.D.INT		15	13	16	II	OC.D.INT						
	16	57	8	I	PA.F.INT		19	42	7	II	EC.F.INT	29	0	41	54	II	OM.D.EXT
	17	0	56	I	PA.F.EXT		19	46	30	II	EC.F.EXT		0	46	20	II	OM.D.INT
	17	53	29	I	OM.F.INT		19	48	5	II	EC.F.PEN		1	4	24	II	PA.F.INT
	17	57	17	I	OM.F.EXT		22	10	2	I	PA.D.EXT		1	8	49	II	PA.F.EXT
							22	13	51	I	PA.D.INT		3	16	11	II	OM.F.INT
19	11	21	15	III	OC.D.EXT		23	9	54	I	OM.D.EXT		3	20	36	II	OM.F.EXT
	11	38	15	III	OC.D.INT		23	13	42	I	OM.D.INT		5	32	5	I	PA.D.EXT
	11	55	23	I	OC.D.EXT								5	35	53	I	PA.D.INT
	11	59	13	I	OC.D.INT	24	0	18	37	I	PA.F.INT		6	35	51	I	OM.D.EXT
	13	10	45	III	OC.F.INT		0	22	26	I	PA.F.EXT		6	39	39	I	OM.D.INT
	13	27	46	III	OC.F.EXT		1	19	18	I	OM.F.INT		7	40	41	I	PA.F.INT
	15	2	47	I	EC.F.INT		1	23	6	I	OM.F.EXT		7	44	30	I	PA.F.EXT
	15	6	37	I	EC.F.EXT		19	16	59	I	OC.D.EXT		8	45	8	I	OM.F.INT
	15	7	22	I	EC.F.PEN		19	20	48	I	OC.D.INT		8	48	56	I	OM.F.EXT
	15	10	51	III	EC.D.PEN		22	29	0	I	EC.F.INT						
	15	16	8	III	EC.D.EXT		22	32	49	I	EC.F.EXT	30	2	39	17	I	OC.D.EXT
	15	33	52	III	EC.D.INT		22	33	34	I	EC.F.PEN		2	43	6	I	OC.D.INT
	17	0	30	III	EC.F.INT								4	36	51	III	PA.D.EXT
	17	18	14	III	EC.F.EXT	25	9	17	55	II	PA.D.EXT		4	53	0	III	PA.D.INT
	17	23	31	III	EC.F.PEN		9	22	19	II	PA.D.INT		5	55	20	I	EC.F.INT
							11	23	4	II	OM.D.EXT		5	59	10	I	EC.F.EXT
20	1	57	26	II	OC.D.EXT		11	27	30	II	OM.D.INT		5	59	55	I	EC.F.PEN
	2	1	48	II	OC.D.INT		11	50	49	II	PA.F.INT		6	29	53	III	PA.F.INT
	6	24	42	II	EC.F.INT		11	55	14	II	PA.F.EXT		6	46	12	III	PA.F.EXT
	6	29	5	II	EC.F.EXT		13	57	24	II	OM.F.INT		9	2	32	III	OM.D.EXT
	6	30	39	II	EC.F.PEN		14	1	49	II	OM.F.EXT		9	18	58	III	OM.D.INT
	9	15	42	I	PA.D.EXT		16	37	18	I	PA.D.EXT		10	56	59	III	OM.F.INT
	9	19	30	I	PA.D.INT		16	41	6	I	PA.D.INT		11	13	13	III	OM.F.EXT
	10	12	38	I	OM.D.EXT		17	38	32	I	OM.D.EXT		17	33	24	II	OC.D.EXT
	10	16	26	I	OM.D.INT		17	42	20	I	OM.D.INT		17	37	44	II	OC.D.INT
	11	24	15	I	PA.F.INT		18	45	53	I	PA.F.INT		22	17	0	II	EC.F.INT
	11	28	4	I	PA.F.EXT		18	49	42	I	PA.F.EXT		22	21	23	II	EC.F.EXT
	12	22	7	I	OM.F.INT		19	47	54	I	OM.F.INT		22	22	58	II	EC.F.PEN
	12	25	55	I	OM.F.EXT		19	51	41	I	OM.F.EXT		23	59	35	I	PA.D.EXT

2006 - PHÉNOMÈNES DES SATELLITES GALILÉENS DE JUPITER
(Temps Terrestre)

JUILLET - PREMIÈRE QUINZAINE																	
jour	h	m	s	SAT.	TYPE	jour	h	m	s	SAT.	TYPE	jour	h	m	s	SAT.	TYPE
1	0	3	22	I	PA.D.INT	3	37	5	II	PA.F.EXT	0	30	18	III	OC.F.EXT		
	1	4	31	I	OM.D.EXT	5	53	12	II	OM.F.INT	3	7	37	III	EC.D.PEN		
	1	8	19	I	OM.D.INT	5	57	38	II	OM.F.EXT	3	12	56	III	EC.D.EXT		
	2	8	11	I	PA.F.INT	7	22	27	I	PA.D.EXT	3	30	45	III	EC.D.INT		
	2	11	59	I	PA.F.EXT	7	26	14	I	PA.D.INT	4	56	48	III	EC.F.INT		
	3	13	45	I	OM.F.INT	8	30	30	I	OM.D.EXT	5	14	38	III	EC.F.EXT		
	3	17	33	I	OM.F.EXT	8	34	18	I	OM.D.INT	5	19	56	III	EC.F.PEN		
	21	6	49	I	OC.D.EXT	9	31	5	I	PA.F.INT	9	14	3	II	OC.D.EXT		
	21	10	38	I	OC.D.INT	9	34	53	I	PA.F.EXT	9	18	22	II	OC.D.INT		
						10	39	38	I	OM.F.INT	14	9	12	II	EC.F.INT		
						10	43	26	I	OM.F.EXT	14	13	35	II	EC.F.EXT		
2	0	24	4	I	EC.F.INT						14	15	9	II	EC.F.PEN		
	0	27	54	I	EC.F.EXT						14	45	56	I	PA.D.EXT		
	0	28	40	I	EC.F.PEN	7	4	30	0	I	OC.D.EXT	14	49	43	I	PA.D.INT	
	11	44	29	II	PA.D.EXT	4	33	49	I	OC.D.INT	14	56	30	I	OM.D.EXT		
	11	48	52	II	PA.D.INT	7	50	28	I	EC.F.INT	16	0	18	I	OM.D.INT		
	14	0	3	II	OM.D.EXT	7	54	18	I	EC.F.EXT	16	54	36	I	PA.F.INT		
	14	4	29	II	OM.D.INT	7	55	3	I	EC.F.PEN	16	58	24	I	PA.F.EXT		
	14	17	54	II	PA.F.INT	8	17	51	III	PA.D.EXT	18	5	33	I	OM.F.INT		
	14	22	18	II	PA.F.EXT	8	33	31	III	PA.D.INT	18	9	21	I	OM.F.EXT		
	16	34	16	II	OM.F.INT	10	14	8	III	PA.F.INT							
	16	38	42	II	OM.F.EXT	10	29	58	III	PA.F.EXT							
	18	27	7	I	PA.D.EXT	13	2	4	III	OM.D.EXT	12	11	53	43	I	OC.D.EXT	
	18	30	54	I	PA.D.INT	13	18	30	III	OM.D.INT	11	57	32	I	OC.D.INT		
	19	33	9	I	OM.D.EXT	14	56	22	III	OM.F.INT	15	16	49	I	EC.F.INT		
	19	36	57	I	OM.D.INT	15	12	35	III	OM.F.EXT	15	20	39	I	EC.F.EXT		
	20	35	44	I	PA.F.INT	19	59	58	II	OC.D.EXT	15	21	24	I	EC.F.PEN		
	20	39	32	I	PA.F.EXT	20	4	18	II	OC.D.INT							
	21	42	22	I	OM.F.INT						13	3	29	6	II	PA.D.EXT	
	21	46	9	I	OM.F.EXT						3	33	29	II	PA.D.INT		
3	15	34	30	I	OC.D.EXT	8	0	51	48	II	EC.F.INT	5	56	17	II	OM.D.EXT	
	15	38	19	I	OC.D.INT	0	56	11	II	EC.F.EXT	6	0	44	II	OM.D.INT		
	18	32	14	III	OC.D.EXT	0	57	46	II	EC.F.PEN	6	3	14	II	PA.F.INT		
	18	48	10	III	OC.D.INT	1	54	0	I	PA.D.INT	6	7	37	II	PA.F.EXT		
	18	52	54	I	EC.F.INT	2	59	10	I	OM.D.EXT	8	30	23	II	OM.F.INT		
	18	56	44	I	EC.F.EXT	3	2	58	I	OM.D.INT	8	34	49	II	OM.F.EXT		
	18	57	29	I	EC.F.PEN	3	58	52	I	PA.F.INT	9	13	52	I	PA.D.EXT		
	20	29	6	III	OC.F.INT	4	2	39	I	PA.F.EXT	9	17	39	I	PA.D.INT		
	20	45	2	III	OC.F.EXT	5	8	16	I	OM.F.INT	10	25	9	I	OM.D.EXT		
	23	8	29	III	EC.D.PEN	5	12	4	I	OM.F.EXT	10	28	57	I	OM.D.INT		
	23	13	46	III	EC.D.EXT	22	57	49	I	OC.D.EXT	11	22	34	I	PA.F.INT		
	23	31	34	III	EC.D.INT	23	1	38	I	OC.D.INT	11	26	21	I	PA.F.EXT		
											12	34	11	I	OM.F.INT		
4	0	57	47	III	EC.F.INT	9	2	19	14	I	EC.F.INT	12	37	59	I	OM.F.EXT	
	1	15	35	III	EC.F.EXT	2	23	4	I	EC.F.EXT	14	6	21	51	I	OC.D.EXT	
	1	20	53	III	EC.F.PEN	2	23	49	I	EC.F.PEN	6	25	40	I	OC.D.INT		
	6	46	25	II	OC.D.EXT	14	13	25	II	PA.D.EXT	9	45	41	I	EC.F.INT		
	6	50	44	II	OC.D.INT	14	17	48	II	PA.D.INT	9	49	31	I	EC.F.EXT		
	11	34	25	II	EC.F.INT	16	37	15	II	OM.D.EXT	9	50	16	I	EC.F.PEN		
	11	38	48	II	EC.F.EXT	16	41	42	II	OM.D.INT	12	2	40	III	PA.D.EXT		
	11	40	23	II	EC.F.PEN	16	47	19	II	PA.F.INT	12	17	57	III	PA.D.INT		
	12	54	46	I	PA.D.EXT	16	51	42	II	PA.F.EXT	14	1	45	III	PA.F.INT		
	12	58	34	I	PA.D.INT	19	11	23	II	OM.F.INT	14	17	12	III	PA.F.EXT		
	14	1	51	I	OM.D.EXT	19	15	49	II	OM.F.EXT	17	0	52	III	OM.D.EXT		
	14	5	39	I	OM.D.INT	20	18	1	I	PA.D.EXT	17	17	18	III	OM.D.INT		
	15	3	24	I	PA.F.INT	20	21	48	I	PA.D.INT	18	55	3	III	OM.F.INT		
	15	7	12	I	PA.F.EXT	21	27	48	I	OM.D.EXT	19	11	15	III	OM.F.EXT		
	16	11	1	I	OM.F.INT	21	31	36	I	OM.D.INT	22	28	41	II	OC.D.EXT		
	16	14	49	I	OM.F.EXT	22	26	41	I	PA.F.INT	22	32	59	II	OC.D.INT		
5	10	2	9	I	OC.D.EXT	22	30	28	I	PA.F.EXT							
	10	5	58	I	OC.D.INT	23	36	53	I	OM.F.INT	15	3	26	36	II	EC.F.INT	
	13	21	37	I	EC.F.INT	23	40	41	I	OM.F.EXT	3	30	58	II	EC.F.EXT		
	13	25	27	I	EC.F.EXT	10	17	25	47	I	OC.D.EXT	3	32	33	II	EC.F.PEN	
	13	26	13	I	EC.F.PEN	17	29	36	I	OC.D.INT	3	41	54	I	PA.D.EXT		
6	0	59	0	II	PA.D.EXT	20	48	5	I	EC.F.INT	3	45	40	I	PA.D.INT		
	1	3	23	II	PA.D.INT	20	51	55	I	EC.F.EXT	4	53	49	I	OM.D.EXT		
	3	19	1	II	OM.D.EXT	20	52	40	I	EC.F.PEN	4	57	37	I	OM.D.INT		
	3	23	28	II	OM.D.INT	22	14	52	III	OC.D.EXT	5	50	36	I	PA.F.INT		
	3	32	41	II	PA.F.INT	22	30	23	III	OC.D.INT	5	54	23	I	PA.F.EXT		
						11	0	14	46	III	OC.F.INT	7	2	50	I	OM.F.INT	
											7	6	37	I	OM.F.EXT		

2006 - PHÉNOMÈNES DES SATELLITES GALILÉENS DE JUPITER
(Temps Terrestre)

JUILLET - DEUXIÈME QUINZAINE																	
jour	h	m	s	SAT.	TYPE	jour	h	m	s	SAT.	TYPE	jour	h	m	s	SAT.	TYPE
16	0	49	57	I	OC.D.EXT	11	40	57	I	EC.F.INT	26	15	40	12	I	OC.D.EXT	
	0	53	46	I	OC.D.INT	11	44	47	I	EC.F.EXT	15	44	0	I	OC.D.INT		
	4	14	27	I	EC.F.INT	11	45	32	I	EC.F.PEN	19	7	21	I	EC.F.INT		
	4	18	17	I	EC.F.EXT	15	51	51	III	PA.D.EXT	19	11	12	I	EC.F.EXT		
	4	19	3	I	EC.F.PEN	16	6	49	III	PA.D.INT	19	11	57	I	EC.F.PEN		
	16	44	39	II	PA.D.EXT	17	53	20	III	PA.F.INT							
	16	49	1	II	PA.D.INT	18	8	28	III	PA.F.EXT	27	8	36	6	II	PA.D.EXT	
	19	14	34	II	OM.D.EXT	20	59	33	III	OM.D.EXT	8	40	27	II	PA.D.INT		
	19	18	59	II	PA.F.INT	21	16	0	III	OM.D.INT	11	11	3	II	PA.F.INT		
	19	19	0	II	OM.D.INT	22	53	40	III	OM.F.INT	11	11	12	II	OM.D.EXT		
	19	23	22	II	PA.F.EXT	23	9	52	III	OM.F.EXT	11	15	25	II	PA.F.EXT		
	21	48	37	II	OM.F.INT						11	15	39	II	OM.D.INT		
	21	53	3	II	OM.F.EXT	22	0	59	24	II	OC.D.EXT	12	59	48	I	PA.D.EXT	
	22	9	57	I	PA.D.EXT	1	3	42	II	OC.D.INT	5	34	36	I	PA.D.EXT		
	22	13	44	I	PA.D.INT	5	34	36	I	PA.D.EXT	5	38	23	I	PA.D.INT		
	23	22	28	I	OM.D.EXT	6	1	19	II	EC.F.INT	6	1	19	II	EC.F.INT		
	23	26	16	I	OM.D.INT	6	5	41	II	EC.F.EXT	6	5	41	II	EC.F.EXT		
17	0	18	40	I	PA.F.INT	6	7	16	II	EC.F.PEN	6	7	16	II	EC.F.PEN		
	0	22	28	I	PA.F.EXT	6	48	30	I	OM.D.EXT	6	48	30	I	OM.D.EXT		
	1	31	28	I	OM.F.INT	6	52	18	I	OM.D.INT	6	52	18	I	OM.D.INT		
	1	35	15	I	OM.F.EXT	7	43	22	I	PA.F.INT	7	43	22	I	PA.F.INT		
	19	18	12	I	OC.D.EXT	7	47	9	I	PA.F.EXT	7	47	9	I	PA.F.EXT		
	19	22	1	I	OC.D.INT	8	57	26	I	OM.F.INT	8	57	26	I	OM.F.INT		
	22	43	19	I	EC.F.INT	9	1	13	I	OM.F.EXT	9	1	13	I	OM.F.EXT		
	22	47	9	I	EC.F.EXT												
	22	47	54	I	EC.F.PEN	23	2	43	12	I	OC.D.EXT	28	10	8	52	I	OC.D.EXT
18	2	2	50	III	OC.D.EXT	2	47	0	I	OC.D.INT	10	12	40	I	OC.D.INT		
	2	18	2	III	OC.D.INT	6	9	44	I	EC.F.INT	13	36	14	I	EC.F.INT		
	4	5	20	III	OC.F.INT	6	13	34	I	EC.F.EXT	13	40	5	I	EC.F.EXT		
	4	20	33	III	OC.F.EXT	6	14	19	I	EC.F.PEN	13	40	50	I	EC.F.PEN		
	7	7	37	III	EC.D.PEN	19	18	9	II	PA.D.EXT	19	45	19	III	PA.D.EXT		
	7	12	56	III	EC.D.EXT	19	22	31	II	PA.D.INT	20	0	1	III	PA.D.INT		
	7	30	47	III	EC.D.INT	21	52	2	II	OM.D.EXT	21	48	46	III	PA.F.INT		
	8	56	41	III	EC.F.INT	21	52	54	II	PA.F.INT	22	3	40	III	PA.F.EXT		
	9	14	33	III	EC.F.EXT	21	56	29	II	OM.D.INT							
	9	19	52	III	EC.F.PEN	21	57	16	II	PA.F.EXT	29	0	58	17	III	OM.D.EXT	
	11	43	48	II	OC.D.EXT						1	14	45	III	OM.D.INT		
	11	48	6	II	OC.D.INT	24	0	2	55	I	PA.D.EXT	2	52	21	III	OM.F.INT	
	16	38	8	I	PA.D.EXT	0	6	42	I	PA.D.INT	3	8	32	III	OM.F.EXT		
	16	41	55	I	PA.D.INT	0	26	3	II	OM.F.INT	3	32	7	II	OC.D.EXT		
	16	43	59	II	EC.F.INT	0	30	29	II	OM.F.EXT	3	36	24	II	OC.D.INT		
	16	48	21	II	EC.F.EXT	1	17	9	I	OM.D.EXT	7	28	18	I	PA.D.EXT		
	16	49	56	II	EC.F.PEN	1	20	57	I	OM.D.INT	7	32	5	I	PA.D.INT		
	17	51	10	I	OM.D.EXT	2	11	42	I	PA.F.INT	8	36	0	II	EC.F.INT		
	17	54	58	I	OM.D.INT	2	15	29	I	PA.F.EXT	8	40	22	II	EC.F.EXT		
	18	46	52	I	PA.F.INT	3	26	5	I	OM.F.INT	8	41	57	II	EC.F.PEN		
	18	50	39	I	PA.F.EXT	3	29	52	I	OM.F.EXT	8	43	11	I	OM.D.EXT		
	20	0	8	I	OM.F.INT	21	11	43	I	OC.D.EXT	8	46	58	I	OM.D.INT		
	20	3	55	I	OM.F.EXT	21	15	31	I	OC.D.INT	9	37	9	I	OM.F.INT		
19	13	46	25	I	OC.D.EXT	25	0	38	36	I	EC.F.INT	9	40	56	I	PA.F.EXT	
	13	50	14	I	OC.D.INT	0	42	26	I	EC.F.EXT	10	52	5	I	OM.F.INT		
	17	12	4	I	EC.F.INT	0	43	11	I	EC.F.PEN	10	55	52	I	OM.F.EXT		
	17	15	54	I	EC.F.EXT	5	54	52	III	OC.D.EXT	30	4	37	30	I	OC.D.EXT	
	17	16	39	I	EC.F.PEN	6	9	48	III	OC.D.INT	4	41	19	I	OC.D.INT		
20	6	1	29	II	PA.D.EXT	7	59	36	III	OC.F.INT	8	5	2	I	EC.F.INT		
	6	5	51	II	PA.D.INT	8	14	32	III	OC.F.EXT	8	8	52	I	EC.F.EXT		
	8	33	41	II	OM.D.EXT	11	7	7	III	EC.D.PEN	8	9	37	I	EC.F.PEN		
	8	36	2	II	PA.F.INT	11	12	26	III	EC.D.EXT	21	53	47	II	PA.D.EXT		
	8	38	7	II	OM.D.INT	11	30	17	III	EC.D.INT	21	58	9	II	PA.D.INT		
	8	40	25	II	PA.F.EXT	12	56	9	III	EC.F.INT							
	11	7	20	I	PA.D.EXT	13	14	1	III	EC.F.EXT	31	0	28	54	II	PA.F.INT	
	11	7	43	II	OM.F.INT	13	19	20	III	EC.F.PEN	0	29	33	II	OM.D.EXT		
	11	10	7	I	PA.D.INT	14	15	32	II	OC.D.EXT	0	33	16	II	PA.F.EXT		
	11	12	9	II	OM.F.EXT	14	19	49	II	OC.D.INT	0	34	0	II	OM.D.INT		
	12	19	50	I	OM.D.EXT	18	31	21	I	PA.D.EXT	1	56	52	I	PA.D.EXT		
	12	23	38	I	OM.D.INT	18	35	7	I	PA.D.INT	2	0	38	I	PA.D.INT		
	13	15	5	I	PA.F.INT	19	18	41	II	EC.F.INT	3	3	34	II	OM.F.INT		
	13	18	52	I	PA.F.EXT	19	23	3	II	EC.F.EXT	3	8	0	II	OM.F.EXT		
	14	28	47	I	OM.F.INT	19	24	38	II	EC.F.PEN	3	11	50	I	OM.D.EXT		
	14	32	34	I	OM.F.EXT	19	45	51	I	OM.D.EXT	3	15	38	I	OM.D.INT		
21	8	14	49	I	OC.D.EXT	19	49	39	I	OM.D.INT	4	5	43	I	PA.F.INT		
	8	18	38	I	OC.D.INT	20	40	9	I	PA.F.INT	4	9	30	I	PA.F.EXT		
						20	43	56	I	PA.F.EXT	5	20	44	I	OM.F.INT		
						21	54	46	I	OM.F.INT	5	24	31	I	OM.F.EXT		
						21	58	33	I	OM.F.EXT	23	6	17	I	OC.D.EXT		
											23	10	5	I	OC.D.INT		

2006 - CONFIGURATIONS DES SATELLITES GALILÉENS DE JUPITER

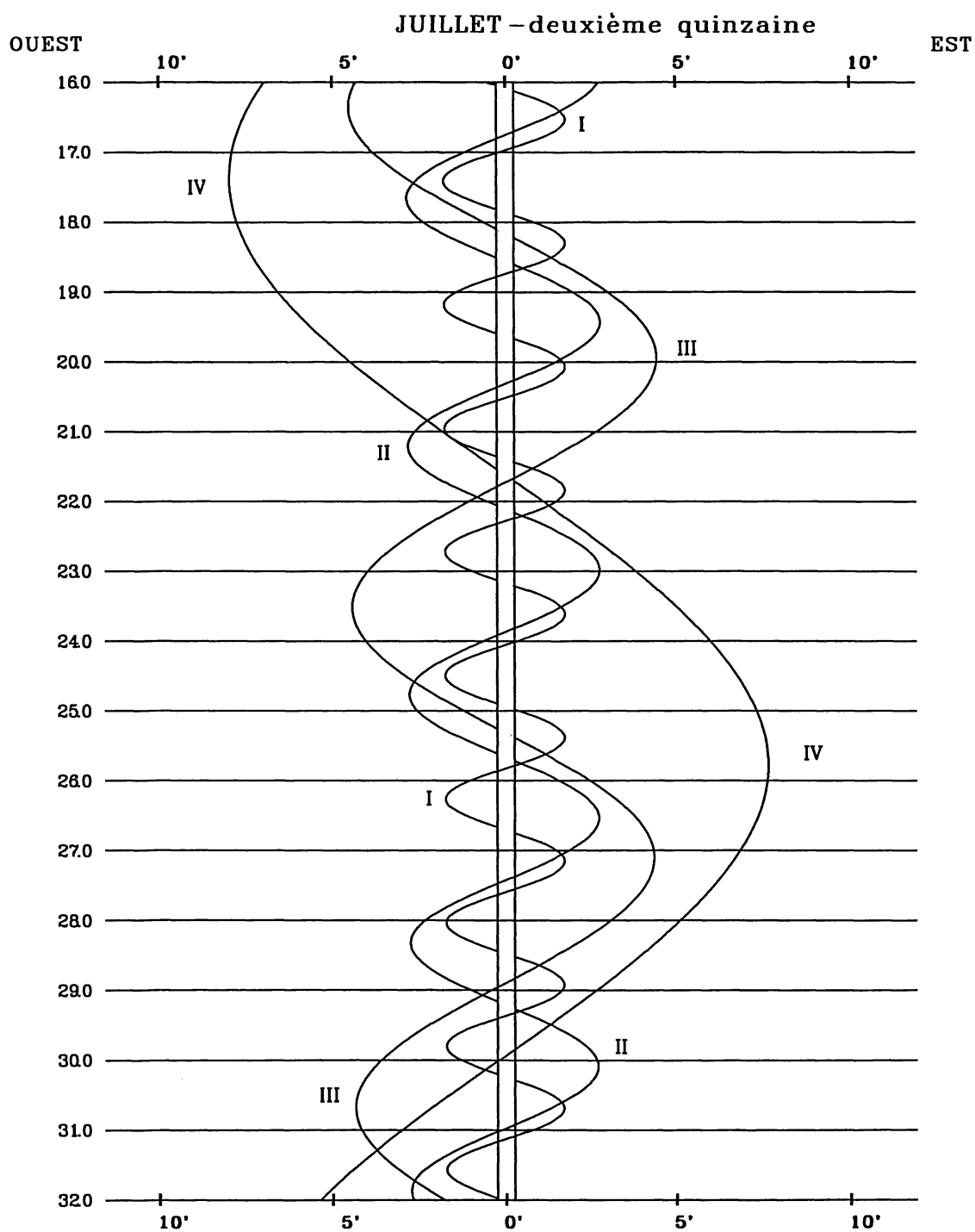

Dans le sens OUEST-EST, les satellites passent au-delà de Jupiter

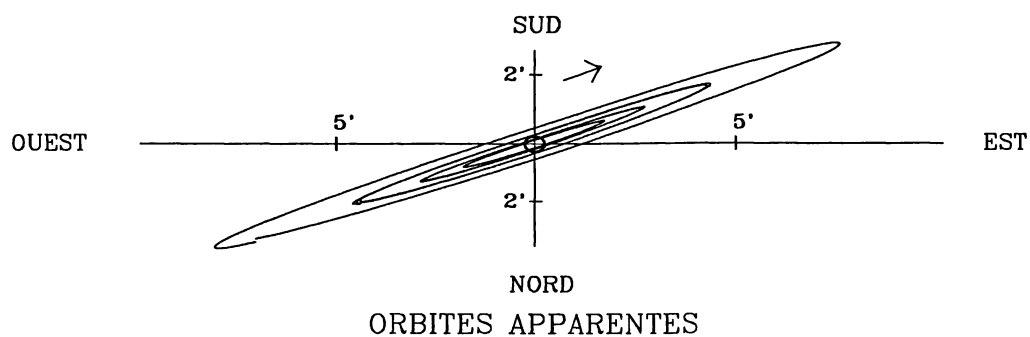

2006 - PHÉNOMÈNES DES SATELLITES GALILÉENS DE JUPITER
 (Temps Terrestre)

AOÛT - PREMIÈRE QUINZAINE																	
jour	h	m	s	SAT.	TYPE	jour	h	m	s	SAT.	TYPE	jour	h	m	s	SAT.	TYPE
1	2	33	55	I	EC.F.INT		11	31	52	I	PA.F.INT	18	58	29	I	PA.F.INT	
	2	37	45	I	EC.F.EXT		11	35	38	I	PA.F.EXT	19	0	29	II	OM.F.INT	
	2	38	30	I	EC.F.PEN		12	46	45	I	OM.F.INT	19	2	15	I	PA.F.EXT	
	9	51	48	III	OC.D.EXT		12	50	32	I	OM.F.EXT	19	4	55	II	OM.F.EXT	
	10	6	31	III	OC.D.INT							20	12	46	I	OM.F.INT	
	11	58	24	III	OC.F.INT		6	32	49	I	OC.D.EXT	20	16	33	I	OM.F.EXT	
	12	13	7	III	OC.F.EXT	6	6	36	37	I	OC.D.INT						
	15	7	6	III	EC.D.PEN		10	0	21	I	EC.F.INT	11	13	59	56	I	OC.D.EXT
	15	12	25	III	EC.D.EXT		10	4	12	I	EC.F.EXT	14	3	45	I	OC.D.INT	
	15	30	16	III	EC.D.INT		10	4	57	I	EC.F.PEN	17	26	53	I	EC.F.INT	
	16	49	14	II	OC.D.EXT							17	30	43	I	EC.F.EXT	
	16	53	31	II	OC.D.INT	7	0	31	29	II	PA.D.EXT	17	31	29	I	EC.F.PEN	
	16	56	10	III	EC.F.INT		0	35	50	II	PA.D.INT						
	17	14	2	III	EC.F.EXT		3	6	57	II	PA.F.INT	12	3	45	31	III	PA.D.EXT
	17	19	21	III	EC.F.PEN		3	7	9	II	OM.D.EXT	3	59	54	III	PA.D.INT	
	20	25	31	I	PA.D.EXT		3	11	18	II	PA.F.EXT	5	51	56	III	PA.F.INT	
	20	29	17	I	PA.D.INT		3	11	36	II	OM.D.INT	6	6	30	III	PA.F.EXT	
	21	40	31	I	OM.D.EXT		3	51	43	I	PA.D.EXT	8	43	4	II	OC.D.EXT	
	21	44	19	I	OM.D.INT		3	55	29	I	PA.D.INT	8	47	20	II	OC.D.INT	
	21	53	22	II	EC.F.INT		5	6	30	I	OM.D.EXT	8	56	53	III	OM.D.EXT	
	21	57	45	II	EC.F.EXT		5	10	18	I	OM.D.INT	9	13	20	III	OM.D.INT	
	21	59	19	II	EC.F.PEN		5	41	10	II	OM.F.INT	10	50	58	III	OM.F.INT	
	22	34	24	I	PA.F.INT		5	45	36	II	OM.F.EXT	11	7	10	III	OM.F.EXT	
	22	38	10	I	PA.F.EXT		6	0	40	I	PA.F.INT	11	18	25	I	PA.D.EXT	
	23	49	25	I	OM.F.INT		6	4	26	I	PA.F.EXT	11	22	11	I	PA.D.INT	
	23	53	12	I	OM.F.EXT		7	15	24	I	OM.F.INT	12	32	30	I	OM.D.EXT	
							7	19	11	I	OM.F.EXT	12	36	18	I	OM.D.INT	
2	17	35	1	I	OC.D.EXT							13	27	27	I	PA.F.INT	
	17	38	49	I	OC.D.INT	8	1	1	50	I	OC.D.EXT	13	31	14	I	PA.F.EXT	
	21	2	41	I	EC.F.INT		1	5	38	I	OC.D.INT	13	45	16	II	EC.F.INT	
	21	6	31	I	EC.F.EXT		4	29	14	I	EC.F.INT	13	49	38	II	EC.F.EXT	
	21	7	16	I	EC.F.PEN		4	33	4	I	EC.F.EXT	13	51	13	II	EC.F.PEN	
							4	33	50	I	EC.F.PEN	14	41	26	I	OM.F.INT	
3	11	12	48	II	PA.D.EXT		13	51	58	III	OC.D.EXT	14	45	13	I	OM.F.EXT	
	11	17	9	II	PA.D.INT		14	6	31	III	OC.D.INT						
	13	48	6	II	PA.F.INT		16	0	2	III	OC.F.INT	13	8	29	3	I	OC.D.EXT
	13	48	46	II	OM.D.EXT		16	14	35	III	OC.F.EXT	8	32	51	I	OC.D.INT	
	13	52	28	II	PA.F.EXT		19	6	17	III	EC.D.PEN	11	55	41	I	EC.F.INT	
	13	53	14	II	OM.D.INT		19	11	36	III	EC.D.EXT	11	59	31	I	EC.F.EXT	
	14	54	12	I	PA.D.EXT		19	24	43	II	OC.D.EXT	12	0	16	I	EC.F.PEN	
	14	57	58	I	PA.D.INT		19	28	59	II	OC.D.INT						
	16	9	11	I	OM.D.EXT		19	29	26	III	EC.D.INT	14	3	11	6	II	PA.D.EXT
	16	12	59	I	OM.D.INT		20	55	24	III	EC.F.INT	3	15	26	II	PA.D.INT	
	16	22	48	II	OM.F.INT		21	13	14	III	EC.F.EXT	5	44	48	II	OM.D.EXT	
	16	27	14	II	OM.F.EXT		21	18	33	III	EC.F.PEN	5	46	51	II	PA.F.INT	
	17	3	6	I	PA.F.INT		22	20	35	I	PA.D.EXT	5	47	24	I	PA.D.EXT	
	17	6	53	I	PA.F.EXT		22	24	21	I	PA.D.INT	5	49	15	II	OM.D.INT	
	18	18	5	I	OM.F.INT		23	35	11	I	OM.D.EXT	5	51	10	I	PA.D.INT	
	18	21	52	I	OM.F.EXT		23	38	59	I	OM.D.INT	5	51	12	II	PA.F.EXT	
												7	1	9	I	OM.D.EXT	
4	12	3	56	I	OC.D.EXT		9	0	27	59	II	EC.F.INT	7	4	57	I	OM.D.INT
	12	7	44	I	OC.D.INT		0	29	34	I	PA.F.INT	7	56	28	I	PA.F.INT	
	15	31	34	I	EC.F.INT		0	32	21	II	EC.F.EXT	8	0	14	I	PA.F.EXT	
	15	35	24	I	EC.F.EXT		0	33	20	I	PA.F.EXT	8	18	52	II	OM.F.INT	
	15	36	9	I	EC.F.PEN		0	33	56	II	EC.F.PEN	8	23	18	II	OM.F.EXT	
	23	43	3	III	PA.D.EXT		1	44	6	I	OM.F.INT	9	10	6	I	OM.F.INT	
	23	57	35	III	PA.D.INT		1	47	53	I	OM.F.EXT	9	13	53	I	OM.F.EXT	
							19	30	48	I	OC.D.EXT						
							19	34	36	I	OC.D.INT	15	2	58	17	I	OC.D.EXT
5	1	48	10	III	PA.F.INT		22	58	0	I	EC.F.INT	3	2	5	I	OC.D.INT	
	2	2	52	III	PA.F.EXT		23	1	50	I	EC.F.EXT	6	24	34	I	EC.F.INT	
	4	57	10	III	OM.D.EXT		23	2	35	I	EC.F.PEN	6	28	24	I	EC.F.EXT	
	5	13	37	III	OM.D.INT							6	29	9	I	EC.F.PEN	
	6	6	43	II	OC.D.EXT							6	29	9	I	EC.F.PEN	
	6	11	0	II	OC.D.INT	10	13	51	31	II	PA.D.EXT	17	55	43	III	OC.D.EXT	
	6	51	13	III	OM.F.INT		13	55	51	II	PA.D.INT	18	10	8	III	OC.D.INT	
	7	7	25	III	OM.F.EXT		16	26	26	II	OM.D.EXT	20	4	56	III	OC.F.INT	
	9	22	56	I	PA.D.EXT		16	27	8	II	PA.F.INT	20	19	21	III	OC.F.EXT	
	9	26	42	I	PA.D.INT		16	30	54	II	OM.D.INT	22	1	55	II	OC.D.EXT	
	10	37	51	I	OM.D.EXT		16	31	29	II	PA.F.EXT	22	6	10	II	OC.D.INT	
	10	41	39	I	OM.D.INT		16	49	29	I	PA.D.EXT	23	5	15	III	EC.D.PEN	
	11	10	40	II	EC.F.INT		16	53	15	I	PA.D.INT	23	10	34	III	EC.D.EXT	
	11	15	2	II	EC.F.EXT		18	3	51	I	OM.D.EXT	23	28	23	III	EC.D.INT	
	11	16	36	II	EC.F.PEN		18	7	39	I	OM.D.INT						

2006 – CONFIGURATIONS DES SATELLITES GALILÉENS DE JUPITER

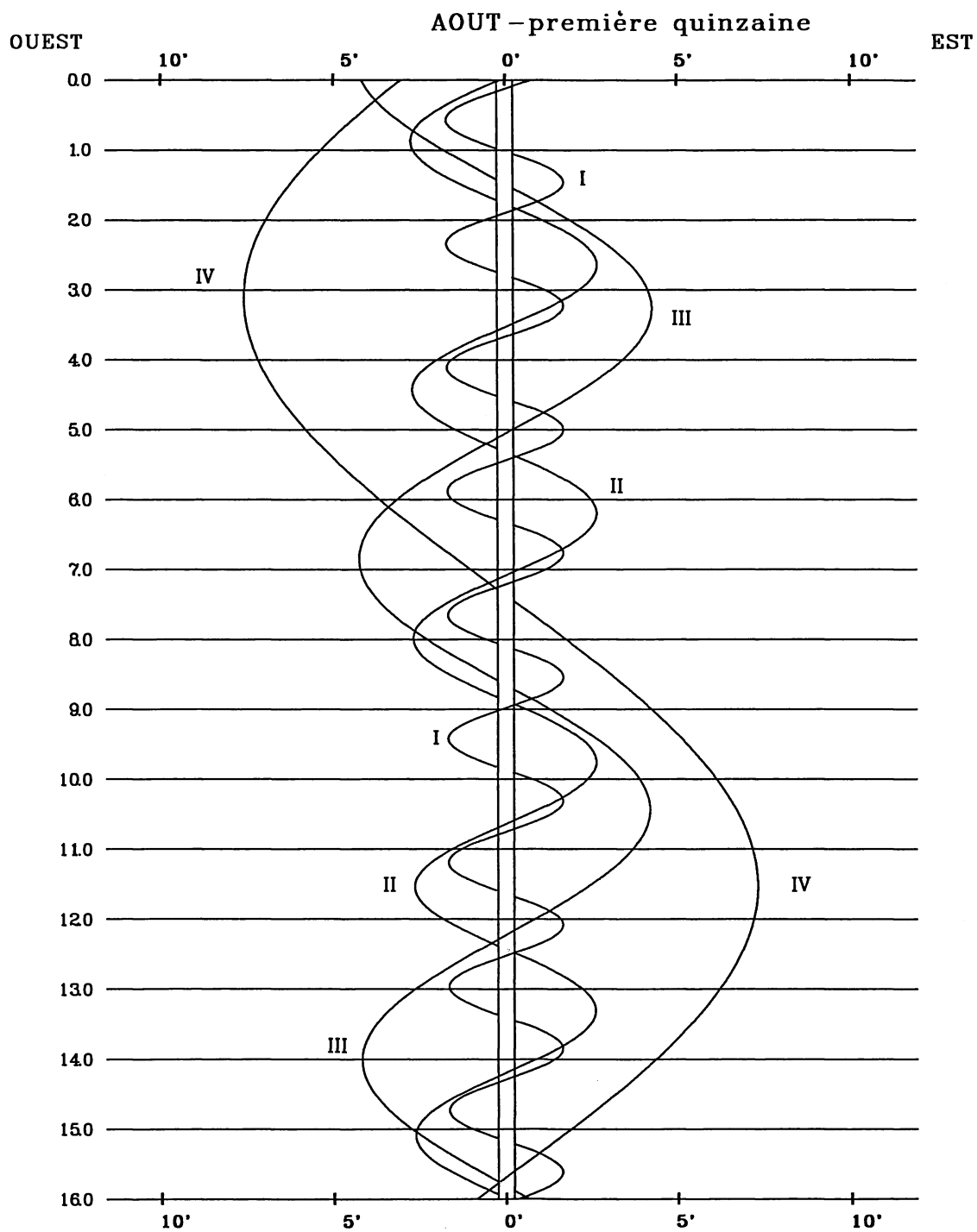

Dans le sens OUEST-EST, les satellites passent au-delà de Jupiter

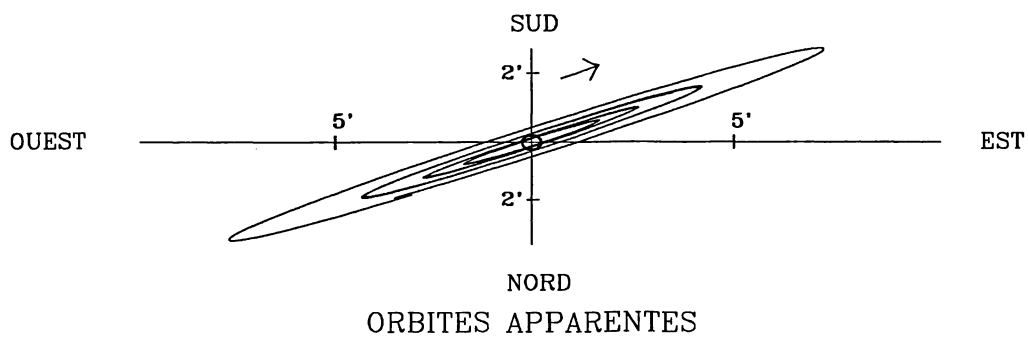

2006 - PHÉNOMÈNES DES SATELLITES GALILÉENS DE JUPITER
(Temps Terrestre)

AOÛT - DEUXIÈME QUINZAINE																	
jour	h	m	s	SAT.	TYPE	jour	h	m	s	SAT.	TYPE	jour	h	m	s	SAT.	TYPE
16	0	16	28	I	PA.D.EXT	8	32	49	II	PA.F.EXT	16	55	30	III	OM.D.EXT		
	0	20	14	I	PA.D.INT	8	55	47	I	OM.D.EXT	17	11	55	III	OM.D.INT		
	0	54	27	III	EC.F.INT	8	59	35	I	OM.D.INT	17	21	0	I	PA.F.INT		
	1	12	16	III	EC.F.EXT	9	53	3	I	PA.F.INT	17	24	46	I	PA.F.EXT		
	1	17	35	III	EC.F.PEN	9	56	49	I	PA.F.EXT	18	30	50	I	OM.F.INT		
	1	29	50	I	OM.D.EXT	10	56	34	II	OM.F.INT	18	34	37	I	OM.F.EXT		
	1	33	37	I	OM.D.INT	11	1	0	II	OM.F.EXT	18	49	53	III	OM.F.INT		
	2	25	34	I	PA.F.INT	11	4	48	I	OM.F.INT	18	54	25	II	EC.F.INT		
	2	29	20	I	PA.F.EXT	11	8	35	I	OM.F.EXT	18	58	47	II	EC.F.EXT		
	3	2	35	II	EC.F.INT						19	0	22	II	EC.F.PEN		
	3	6	57	II	EC.F.EXT	22	4	55	35	I	OC.D.EXT	19	6	4	III	OM.F.EXT	
	3	8	31	II	EC.F.PEN	22	8	19	53	I	EC.F.INT	27	12	24	1	I	OC.D.EXT
	3	38	47	I	OM.F.INT	22	8	23	43	I	EC.F.EXT	27	12	27	49	I	OC.D.INT
	3	42	34	I	OM.F.EXT	22	8	24	28	I	EC.F.PEN	27	15	46	18	I	EC.F.INT
	21	27	28	I	OC.D.EXT	22	3	0	III	OC.D.EXT	27	15	50	8	I	EC.F.EXT	
	21	31	16	I	OC.D.INT	22	17	20	III	OC.D.INT	27	15	50	53	I	EC.F.PEN	
17	0	53	20	I	EC.F.INT												
	0	57	10	I	EC.F.EXT	23	0	13	2	III	OC.F.INT	28	8	35	28	II	PA.D.EXT
	0	57	55	I	EC.F.PEN	23	0	27	23	III	OC.F.EXT	28	8	39	49	II	PA.D.INT
	16	32	1	II	PA.D.EXT	23	0	40	41	II	OC.D.EXT	28	9	41	4	I	PA.D.EXT
	16	36	21	II	PA.D.INT	23	0	44	56	II	OC.D.INT	28	9	44	50	I	PA.D.INT
	18	45	34	I	PA.D.EXT	23	2	13	8	I	PA.D.EXT	28	10	50	23	I	OM.D.EXT
	18	49	20	I	PA.D.INT	23	2	16	53	I	PA.D.INT	28	10	54	11	I	OM.D.INT
	19	4	5	II	OM.D.EXT	23	3	4	19	III	EC.D.PEN	28	11	0	7	II	OM.D.EXT
	19	7	54	II	PA.F.INT	23	3	9	38	III	EC.D.EXT	28	11	4	35	II	OM.D.INT
	19	8	33	II	OM.D.INT	23	3	24	27	I	OM.D.EXT	28	11	11	42	II	PA.F.INT
	19	12	16	II	PA.F.EXT	23	3	27	27	III	EC.D.INT	28	11	16	4	II	PA.F.EXT
	19	58	30	I	OM.D.EXT	23	3	28	15	I	OM.D.INT	28	11	50	23	I	PA.F.INT
	20	2	17	I	OM.D.INT	23	4	22	20	I	PA.F.INT	28	11	54	9	I	PA.F.EXT
	20	54	41	I	PA.F.INT	23	4	26	6	I	PA.F.EXT	28	12	59	30	I	OM.F.INT
	20	58	27	I	PA.F.EXT	23	4	53	34	III	EC.F.INT	28	13	3	17	I	OM.F.EXT
	21	38	10	II	OM.F.INT	23	5	11	23	III	EC.F.EXT	28	13	34	19	II	OM.F.INT
	21	42	37	II	OM.F.EXT	23	5	16	42	III	EC.F.PEN	28	13	38	45	II	OM.F.EXT
	22	7	28	I	OM.F.INT	23	5	33	29	I	OM.F.INT						
	22	11	15	I	OM.F.EXT	23	5	37	9	II	EC.F.INT	29	6	53	39	I	OC.D.EXT
18	15	56	49	I	OC.D.EXT	23	5	37	16	I	OM.F.EXT	29	6	57	27	I	OC.D.INT
	16	0	38	I	OC.D.INT	23	5	41	31	II	EC.F.EXT	29	10	15	10	I	EC.F.INT
	19	22	13	I	EC.F.INT	23	5	43	5	II	EC.F.PEN	29	10	19	0	I	EC.F.EXT
	19	26	3	I	EC.F.EXT	23	23	24	58	I	OC.D.EXT	29	10	19	46	I	EC.F.PEN
	19	26	48	I	EC.F.PEN	23	23	28	46	I	OC.D.INT						
19	7	51	8	III	PA.D.EXT	24	2	48	38	I	EC.F.INT	30	2	13	45	III	OC.D.EXT
	8	5	26	III	PA.D.INT	24	2	52	28	I	EC.F.EXT	30	2	28	2	III	OC.D.INT
	9	58	36	III	PA.F.INT	24	2	53	14	I	EC.F.PEN	30	3	20	54	II	OC.D.EXT
	10	13	3	III	PA.F.EXT	24	19	14	14	II	PA.D.EXT	30	3	25	9	II	OC.D.INT
	11	21	6	II	OC.D.EXT	24	19	18	34	II	PA.D.INT	30	4	10	29	I	PA.D.EXT
	11	25	21	II	OC.D.INT	24	19	18	34	II	PA.D.INT	30	4	14	15	I	PA.D.INT
	12	56	1	III	OM.D.EXT	24	20	42	25	I	PA.D.EXT	30	4	24	20	III	OC.F.INT
	13	12	28	III	OM.D.INT	24	20	46	10	I	PA.D.INT	30	4	38	37	III	OC.F.EXT
	13	14	42	I	PA.D.EXT	24	21	41	45	II	OM.D.EXT	30	5	19	3	I	OM.D.EXT
	13	18	28	I	PA.D.INT	24	21	46	13	II	OM.D.INT	30	5	22	50	I	OM.D.INT
	14	27	9	I	OM.D.EXT	24	21	50	21	II	PA.F.INT	30	6	19	50	I	PA.F.INT
	14	30	56	I	OM.D.INT	24	21	53	7	I	OM.D.EXT	30	6	23	36	I	PA.F.EXT
	14	50	13	III	OM.F.INT	24	21	54	43	II	PA.F.EXT	30	7	3	33	III	EC.D.PEN
	15	6	25	III	OM.F.EXT	24	21	56	54	I	OM.D.INT	30	7	8	51	III	EC.D.EXT
	15	23	51	I	PA.F.INT	24	22	51	39	I	PA.F.INT	30	7	26	39	III	EC.D.INT
	15	27	37	I	PA.F.EXT	24	22	55	25	I	PA.F.EXT	30	7	28	11	I	OM.F.INT
	16	19	52	II	EC.F.INT	25	0	2	10	I	OM.F.INT	30	7	31	58	I	OM.F.EXT
	16	24	15	II	EC.F.EXT	25	0	5	57	I	OM.F.EXT	30	8	11	40	II	EC.F.INT
	16	25	49	II	EC.F.PEN	25	0	15	54	II	OM.F.INT	30	8	16	2	II	EC.F.EXT
	16	36	8	I	OM.F.INT	25	0	20	20	II	OM.F.EXT	30	8	17	37	II	EC.F.PEN
	16	39	55	I	OM.F.EXT	25	17	54	31	I	OC.D.EXT	30	8	52	54	III	EC.F.INT
20	10	26	8	I	OC.D.EXT	25	17	58	19	I	OC.D.INT	30	9	10	42	III	EC.F.EXT
	10	29	56	I	OC.D.INT	25	21	17	31	I	EC.F.INT	30	9	16	1	III	EC.F.PEN
	13	51	0	I	EC.F.INT	25	21	21	21	I	EC.F.EXT	31	1	23	12	I	OC.D.EXT
	13	54	50	I	EC.F.EXT	25	21	22	6	I	EC.F.PEN	31	1	27	0	I	OC.D.INT
	13	55	36	I	EC.F.PEN	26	12	0	35	III	PA.D.EXT	31	4	43	55	I	EC.F.INT
21	5	52	27	II	PA.D.EXT	26	12	14	49	III	PA.D.INT	31	4	47	45	I	EC.F.EXT
	5	56	48	II	PA.D.INT	26	14	0	36	II	OC.D.EXT	31	4	48	31	I	EC.F.PEN
	7	43	53	I	PA.D.EXT	26	14	4	51	II	OC.D.INT	31	21	57	58	II	PA.D.EXT
	7	47	38	I	PA.D.INT	26	14	8	51	III	PA.F.INT	31	22	2	19	II	PA.D.INT
	8	22	27	II	OM.D.EXT	26	14	23	13	III	PA.F.EXT	31	22	39	56	I	PA.D.EXT
	8	26	54	II	OM.D.INT	26	15	11	43	I	PA.D.EXT	31	22	43	42	I	PA.D.INT
	8	28	28	II	PA.F.INT	26	15	15	29	I	PA.D.INT	31	23	47	42	I	OM.D.EXT
						26	16	21	45	I	OM.D.EXT	31	23	51	30	I	OM.D.INT

2006 – CONFIGURATIONS DES SATELLITES GALILÉENS DE JUPITER

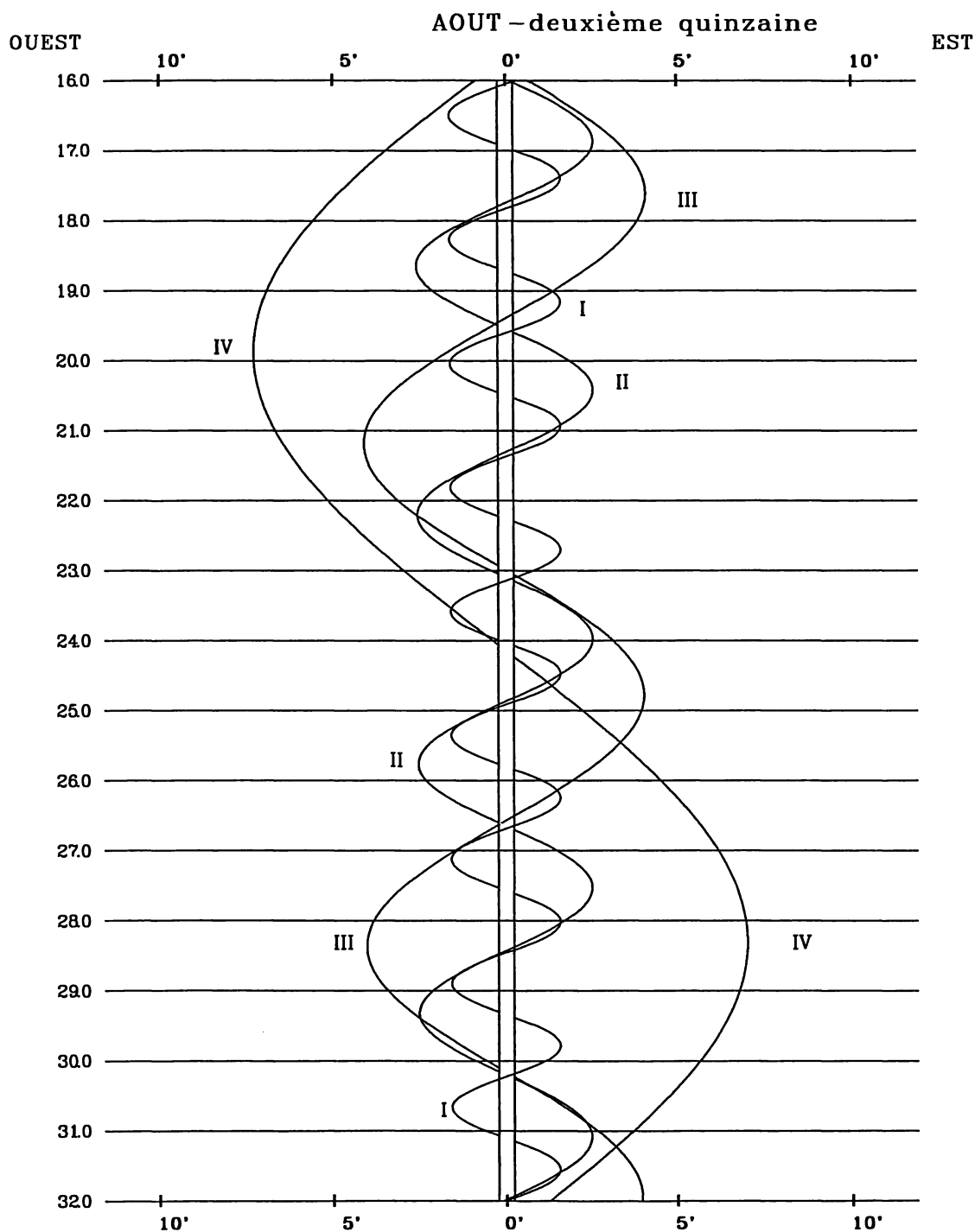

Dans le sens OUEST-EST, les satellites passent au-delà de Jupiter

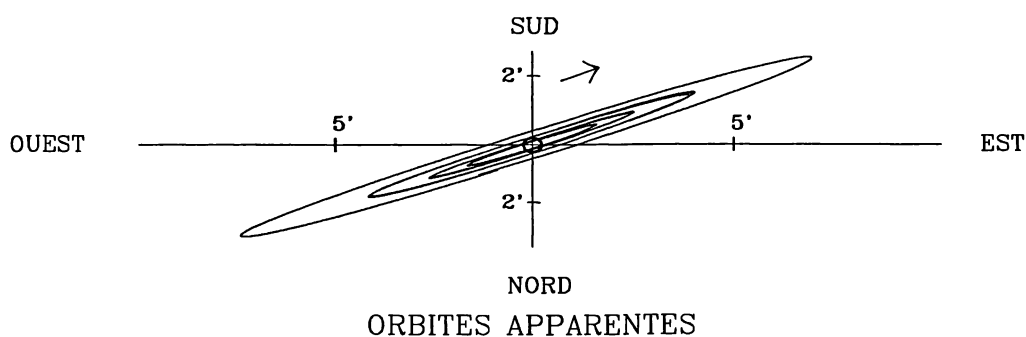

2006 - PHÉNOMÈNES DES SATELLITES GALILÉENS DE JUPITER
(Temps Terrestre)

SEPTEMBRE - PREMIÈRE QUINZAINE																	
jour	h	m	s	SAT.	TYPE	jour	h	m	s	SAT.	TYPE	jour	h	m	s	SAT.	TYPE
1	0	19	23	II	OM.D.EXT												
	0	23	50	II	OM.D.INT												
	0	34	18	II	PA.F.INT												
	0	38	39	II	PA.F.EXT												
	0	49	19	I	PA.F.INT												
	0	53	5	I	PA.F.EXT												
	1	56	52	I	OM.F.INT												
	2	0	39	I	OM.F.EXT												
	2	53	36	II	OM.F.INT												
	2	58	3	II	OM.F.EXT												
	19	52	55	I	OC.D.EXT												
	19	56	43	I	OC.D.INT												
	23	12	47	I	EC.F.INT												
	23	16	37	I	EC.F.EXT												
	23	17	22	I	EC.F.PEN												
2	16	12	21	III	PA.D.EXT												
	16	26	33	III	PA.D.INT												
	16	41	33	II	OC.D.EXT												
	16	45	48	II	OC.D.INT												
	17	9	25	I	PA.D.EXT												
	17	13	10	I	PA.D.INT												
	18	16	20	I	OM.D.EXT												
	18	20	7	I	OM.D.INT												
	18	21	10	III	PA.F.INT												
	18	35	29	III	PA.F.EXT												
	19	18	49	I	PA.F.INT												
	19	22	35	I	PA.F.EXT												
	20	25	31	I	OM.F.INT												
	20	29	18	I	OM.F.EXT												
	20	54	12	III	OM.D.EXT												
	21	10	36	III	OM.D.INT												
	21	28	58	II	EC.F.INT												
	21	33	20	II	EC.F.EXT												
	21	34	55	II	EC.F.PEN												
	22	48	48	III	OM.F.INT												
	23	4	59	III	OM.F.EXT												
3	14	22	36	I	OC.D.EXT												
	14	26	24	I	OC.D.INT												
	17	41	34	I	EC.F.INT												
	17	45	24	I	EC.F.EXT												
	17	46	9	I	EC.F.PEN												
4	11	19	55	II	PA.D.EXT												
	11	24	15	II	PA.D.INT												
	11	38	55	I	PA.D.EXT												
	11	42	41	I	PA.D.INT												
	12	44	57	I	OM.D.EXT												
	12	48	45	I	OM.D.INT												
	13	37	43	II	OM.D.EXT												
	13	42	11	II	OM.D.INT												
	13	48	22	I	PA.F.INT												
	13	52	8	I	PA.F.EXT												
	13	56	19	II	PA.F.INT												
	14	0	41	II	PA.F.EXT												
	14	54	11	I	OM.F.INT												
	14	57	58	I	OM.F.EXT												
	16	11	59	II	OM.F.INT												
	16	16	26	II	OM.F.EXT												
5	8	52	24	I	OC.D.EXT												
	8	56	12	I	OC.D.INT												
	12	10	26	I	EC.F.INT												
	12	14	16	I	EC.F.EXT												
	12	15	1	I	EC.F.PEN												
6	6	2	30	II	OC.D.EXT												
	6	6	45	II	OC.D.INT												
	6	8	29	I	PA.D.EXT												
	6	12	15	I	PA.D.INT												
	6	28	14	III	OC.D.EXT												
	6	42	30	III	OC.D.INT												
						7	13	36	I	OM.D.EXT							
						7	17	24	I	OM.D.INT							
						8	17	58	I	PA.F.INT							
						8	21	44	I	PA.F.EXT		11	13	37	21	I	PA.D.EXT
						8	39	7	III	OC.F.INT			13	41	6	I	PA.D.INT
						8	53	23	III	OC.F.EXT			14	5	41	II	PA.D.EXT
						9	22	51	I	OM.F.INT			14	10	2	II	PA.D.INT
						9	26	38	I	OM.F.EXT			14	39	29	I	OM.D.EXT
						10	46	13	II	EC.F.INT			14	43	17	I	OM.D.INT
						10	50	35	II	EC.F.EXT			15	46	56	I	PA.F.INT
						10	52	10	II	EC.F.PEN			15	50	42	I	PA.F.EXT
						11	3	32	III	EC.D.PEN			16	15	17	II	OM.D.EXT
						11	8	50	III	EC.D.EXT			16	19	44	II	OM.D.INT
						11	26	37	III	EC.D.INT			16	42	13	II	PA.F.INT
						11	52	1	III	EC.F.INT			16	46	35	II	PA.F.EXT
						12	53	1	III	EC.F.EXT			16	48	51	I	OM.F.INT
						13	10	48	III	EC.F.EXT			16	52	38	I	OM.F.EXT
						13	16	6	III	EC.F.PEN			18	49	38	II	OM.F.INT
													18	54	5	II	OM.F.EXT
7	3	22	6	I	OC.D.EXT												
	3	25	54	I	OC.D.INT												
	6	39	10	I	EC.F.INT												
	6	43	0	I	EC.F.EXT												
	6	43	45	I	EC.F.PEN												
8	0	38	5	I	PA.D.EXT												
	0	41	51	I	PA.D.INT												
	0	43	5	II	PA.D.EXT												
	0	47	26	II	PA.D.INT												
	1	42	15	I	OM.D.EXT												
	1	46	2	I	OM.D.INT												
	2	47	36	I	PA.F.INT												
	2	51	22	I	PA.F.EXT												
	2	56	56	II	OM.D.EXT												
	3	1	24	II	OM.D.INT												
	3	19	34	II	PA.F.INT												
	3	23	55	II	PA.F.EXT												
	3	51	32	I	OM.F.INT												
	3	55	19	I	OM.F.EXT												
	5	31	15	II	OM.F.INT												
	5	35	41	II	OM.F.EXT												
	21	51	59	I	OC.D.EXT												
	21	55	47	I	OC.D.INT												
9	1	8	1	I	EC.F.INT												
	1	11	51	I	EC.F.EXT												
	1	12	36	I	EC.F.PEN												
	19	7	42	I	PA.D.EXT												
	19	11	27	I	PA.D.INT												
	19	23	44	II	OC.D.EXT												
	19	27	59	II	OC.D.INT												
	20	10	52	I	OM.D.EXT												
	20	14	40	I	OM.D.INT												
	20	26	46	III	PA.D.EXT												
	20	40	57	III	PA.D.INT												
	21	17	15	I	PA.F.INT												
	21	21	1	I	PA.F.EXT												
	22	20	11	I	OM.F.INT												
	22	23	58	I	OM.F.EXT												
	22	35	55	III	PA.F.INT												
	22	50	13	III	PA.F.EXT												
10	0	3	28	II	EC.F.INT												
	0	7	51	II	EC.F.EXT												
	0	9	26	II	EC.F.PEN												

2006 – CONFIGURATIONS DES SATELLITES GALILÉENS DE JUPITER

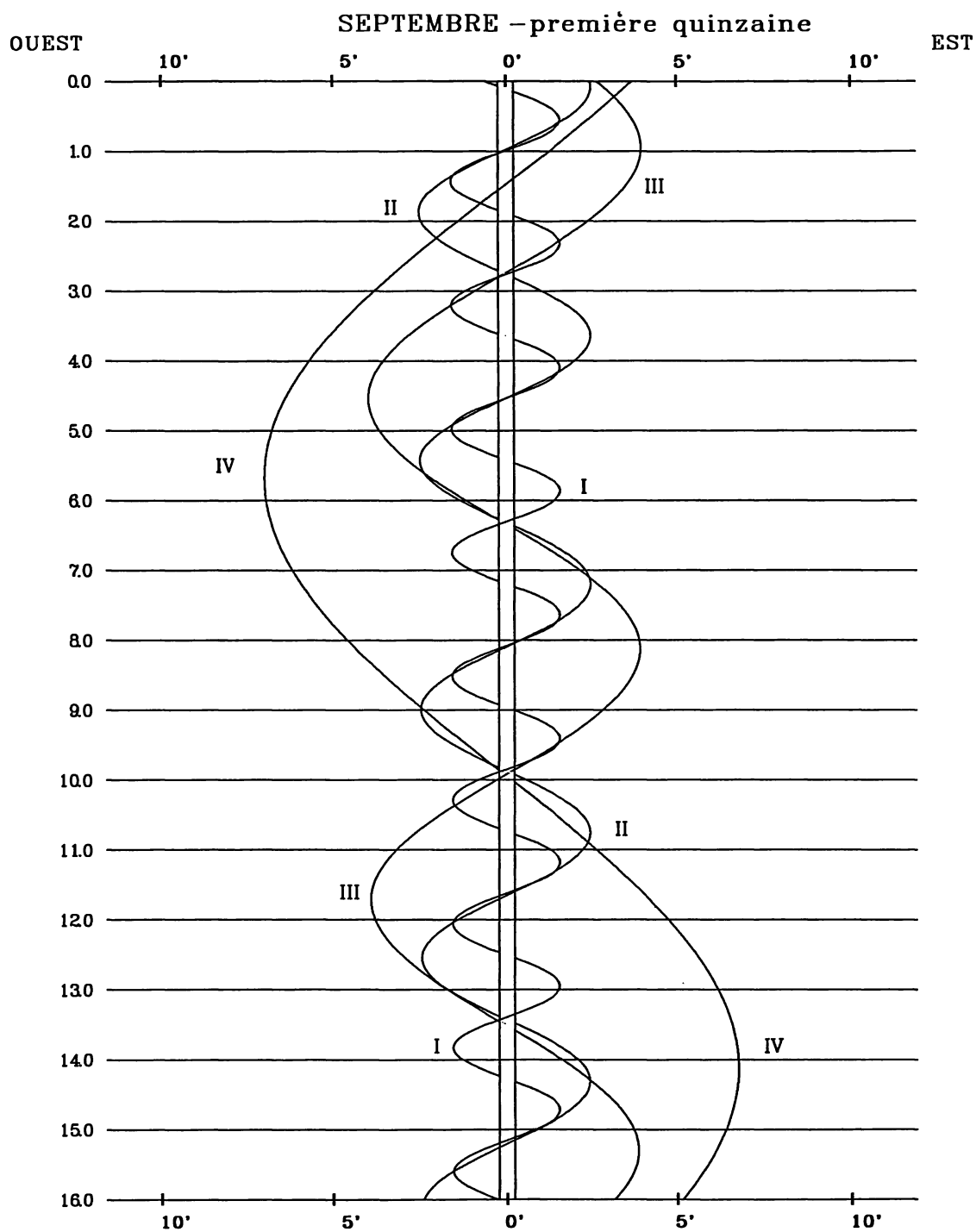

Dans le sens OUEST-EST, les satellites passent au-delà de Jupiter

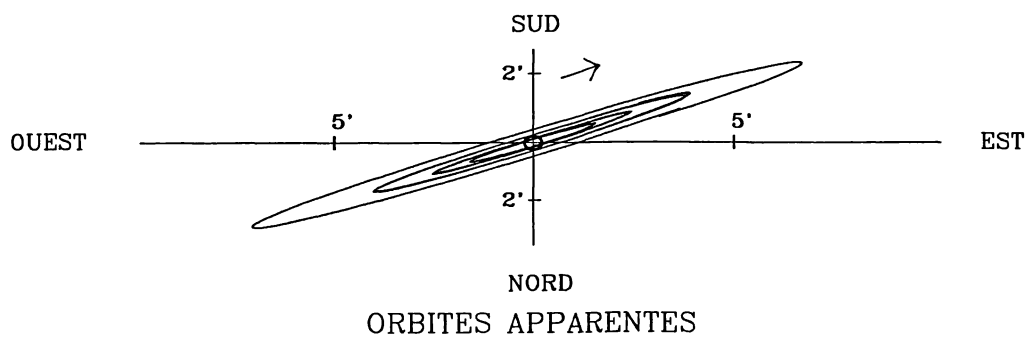

2006 - CONFIGURATIONS DES SATELLITES GALILÉENS DE JUPITER

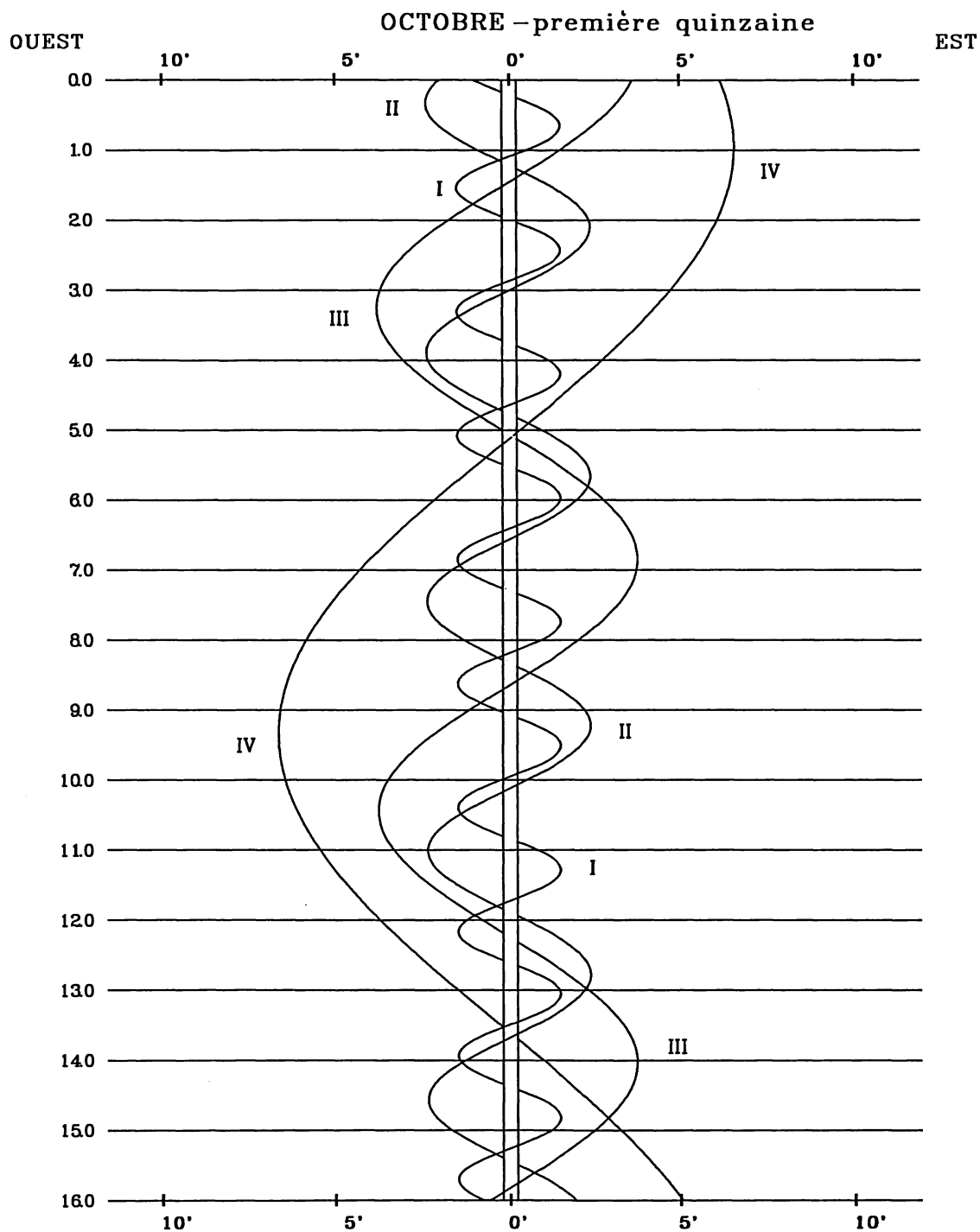

Dans le sens OUEST-EST, les satellites passent au-delà de Jupiter

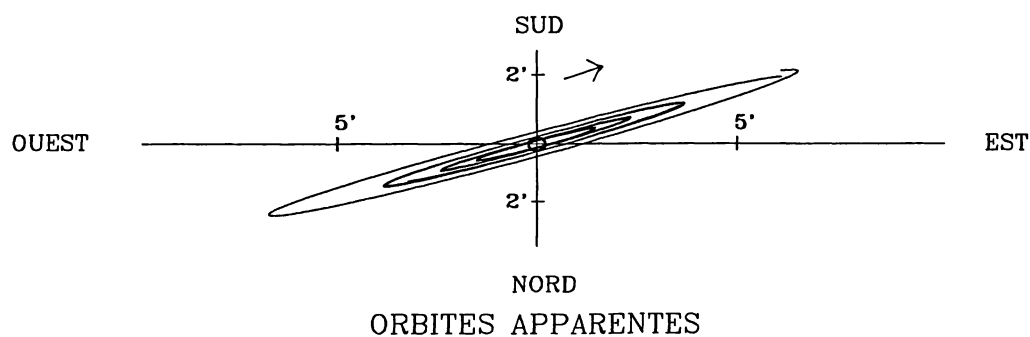

2006 - PHÉNOMÈNES DES SATELLITES GALILÉENS DE JUPITER
(Temps Terrestre)

OCTOBRE - DEUXIÈME QUINZAINE																	
jour	h	m	s	SAT.	TYPE	jour	h	m	s	SAT.	TYPE	jour	h	m	s	SAT.	TYPE
16	2	24	38	I	OC.D.EXT	21	9	55	44	I	OC.D.EXT	17	26	51	I	OC.D.EXT	
	2	28	26	I	OC.D.INT		9	59	32	I	OC.D.INT		17	30	38	I	OC.D.INT
	5	11	49	I	EC.F.INT		12	37	54	I	EC.F.INT		20	3	53	I	EC.F.INT
	5	15	38	I	EC.F.EXT		12	41	44	I	EC.F.EXT		20	7	42	I	EC.F.EXT
	5	16	23	I	EC.F.PEN		12	42	29	I	EC.F.PEN		20	8	27	I	EC.F.PEN
23	36	15	I	PA.D.EXT	22	7	6	47	I	PA.D.EXT	27	14	37	28	I	PA.D.EXT	
23	40	1	I	PA.D.INT		7	10	33	I	PA.D.INT		14	41	14	I	PA.D.INT	
17	0	11	26	I		OM.D.EXT	7	37	6	I		OM.D.EXT	15	2	46	I	OM.D.EXT
	0	15	13	I		OM.D.INT	7	40	54	I		OM.D.INT	15	6	34	I	OM.D.INT
	1	46	34	I		PA.F.INT	9	17	12	I		PA.F.INT	16	47	57	I	PA.F.INT
	1	50	20	I	PA.F.EXT	9	20	58	I	PA.F.EXT	16	51	44	I	PA.F.EXT		
	2	21	34	I	OM.F.INT	9	47	21	I	OM.F.INT	17	13	7	I	OM.F.INT		
	2	25	21	I	OM.F.EXT	9	51	8	I	OM.F.EXT	17	16	55	I	OM.F.EXT		
	4	8	39	II	PA.D.EXT	11	57	36	II	OC.D.EXT	20	24	40	II	PA.D.EXT		
	4	13	1	II	PA.D.INT	12	1	54	II	OC.D.INT	20	29	2	II	PA.D.INT		
	5	21	16	II	OM.D.EXT	15	30	40	II	EC.F.INT	21	16	33	II	OM.D.EXT		
	5	25	43	II	OM.D.INT	15	35	3	II	EC.F.EXT	21	21	0	II	OM.D.INT		
	6	45	8	II	PA.F.INT	15	36	39	II	EC.F.PEN	23	0	53	II	PA.F.INT		
	6	49	30	II	PA.F.EXT	22	39	26	III	PA.D.EXT	23	5	16	II	PA.F.EXT		
	7	55	57	II	OM.F.INT	22	53	58	III	PA.D.INT	23	51	15	II	OM.F.INT		
8	0	24	II	OM.F.EXT	23	0	45	37	III	OM.D.EXT	23	55	41	II	OM.F.EXT		
20	55	2	I	OC.D.EXT		0	47	30	III	PA.F.INT	28	11	57	17	I	OC.D.EXT	
20	58	50	I	OC.D.INT		1	1	47	III	OM.D.INT		12	1	4	I	OC.D.INT	
23	40	34	I	EC.F.INT		1	2	3	III	PA.F.EXT		14	32	34	I	EC.F.INT	
23	44	23	I	EC.F.EXT		2	42	27	III	OM.F.INT		14	36	23	I	EC.F.EXT	
23	45	8	I	EC.F.PEN	2	58	32	III	OM.F.EXT	14		37	8	I	EC.F.PEN		
18	18	6	24	I	PA.D.EXT	4	26	5	I	OC.D.EXT	29	9	7	41	I	PA.D.EXT	
	18	10	10	I	PA.D.INT	4	29	52	I	OC.D.INT		9	11	28	I	PA.D.INT	
	18	39	59	I	OM.D.EXT	7	6	33	I	EC.F.INT		9	31	17	I	OM.D.EXT	
	18	43	46	I	OM.D.INT	7	10	22	I	EC.F.EXT		9	35	5	I	OM.D.INT	
	20	16	45	I	PA.F.INT	7	11	7	I	EC.F.PEN		11	18	12	I	PA.F.INT	
	20	20	31	I	PA.F.EXT	24	1	37	0	I	PA.D.EXT	11	21	59	I	PA.F.EXT	
	20	50	9	I	OM.F.INT		1	40	46	I	PA.D.INT	11	41	40	I	OM.F.INT	
	20	53	56	I	OM.F.EXT		2	5	39	I	OM.D.EXT	11	45	28	I	OM.F.EXT	
	22	33	42	II	OC.D.EXT		2	9	27	I	OM.D.INT	14	45	44	II	OC.D.EXT	
	22	37	59	II	OC.D.INT		3	47	26	I	PA.F.INT	14	50	2	II	OC.D.INT	
19	2	13	21	II	EC.F.INT		3	51	12	I	PA.F.EXT	18	5	16	II	EC.F.INT	
	2	17	44	II	EC.F.EXT		4	15	56	I	OM.F.INT	18	9	40	II	EC.F.EXT	
	2	19	20	II	EC.F.PEN		4	19	44	I	OM.F.EXT	18	11	16	II	EC.F.PEN	
	8	37	25	III	OC.D.EXT		6	59	2	II	PA.D.EXT	30	3	6	1	III	PA.D.EXT
	8	51	51	III	OC.D.INT		7	3	24	II	PA.D.INT		3	20	38	III	PA.D.INT
	10	57	23	III	EC.D.PEN	7	57	58	II	OM.D.EXT	4		43	43	III	OM.D.EXT	
	11	2	38	III	EC.D.EXT	8	2	24	II	OM.D.INT	4		59	51	III	OM.D.INT	
	10	46	51	III	OC.F.INT	9	35	22	II	PA.F.INT	5		13	36	III	PA.F.INT	
	11	1	17	III	OC.F.EXT	9	39	44	II	PA.F.EXT	5		28	14	III	PA.F.EXT	
	11	20	6	III	EC.D.INT	10	32	40	II	OM.F.INT	6		27	39	I	OC.D.EXT	
	12	48	32	III	EC.F.INT	10	37	6	II	OM.F.EXT	6		31	26	I	OC.D.INT	
	13	5	59	III	EC.F.EXT	22	56	31	I	OC.D.EXT	6		40	58	III	OM.F.INT	
	13	11	15	III	EC.F.PEN	23	0	19	I	OC.D.INT	6		57	1	III	OM.F.EXT	
	15	25	20	I	OC.D.EXT	25	1	35	16	I	EC.F.INT	9	1	11	I	EC.F.INT	
	15	29	7	I	OC.D.INT		1	39	6	I	EC.F.EXT	9	5	0	I	EC.F.EXT	
	18	9	11	I	EC.F.INT		1	39	51	I	EC.F.PEN	9	5	45	I	EC.F.PEN	
18	13	1	I	EC.F.EXT	20		7	12	I	PA.D.EXT	31	3	37	57	I	PA.D.EXT	
18	13	46	I	EC.F.PEN	20		10	58	I	PA.D.INT		3	41	43	I	PA.D.INT	
20	12	36	37	I	PA.D.EXT		20	34	12	I		OM.D.EXT	3	59	50	I	OM.D.EXT
	12	40	23	I	PA.D.INT		20	37	59	I		OM.D.INT	4	3	38	I	OM.D.INT
	13	8	34	I	OM.D.EXT		22	17	40	I		PA.F.INT	5	48	29	I	PA.F.INT
	13	12	22	I	OM.D.INT		22	21	26	I		PA.F.EXT	5	52	16	I	PA.F.EXT
	14	46	59	I	PA.F.INT		22	44	30	I		OM.F.INT	6	10	15	I	OM.F.INT
	14	50	45	I	PA.F.EXT	22	48	18	I	OM.F.EXT		6	14	3	I	OM.F.EXT	
	15	18	47	I	OM.F.INT	26	1	21	37	II		OC.D.EXT	9	49	43	II	PA.D.EXT
	15	22	34	I	OM.F.EXT		1	25	55	II		OC.D.INT	9	54	5	II	PA.D.INT
	17	34	10	II	PA.D.EXT		4	47	59	II	EC.F.INT	10	34	29	II	OM.D.EXT	
	17	38	32	II	PA.D.INT		4	52	23	II	EC.F.EXT	10	38	55	II	OM.D.INT	
	18	39	59	II	OM.D.EXT		4	53	58	II	EC.F.PEN	12	25	50	II	PA.F.INT	
18	44	26	II	OM.D.INT	13		4	52	III	OC.D.EXT	12	30	13	II	PA.F.EXT		
20	10	33	II	PA.F.INT	13		19	23	III	OC.D.INT	13	9	11	II	OM.F.INT		
20	14	56	II	PA.F.EXT	16		48	19	III	EC.F.INT	13	13	37	II	OM.F.EXT		
21	14	40	II	OM.F.INT	17		5	43	III	EC.F.EXT							
21	19	6	II	OM.F.EXT	17		10	58	III	EC.F.PEN							

2006 – CONFIGURATIONS DES SATELLITES GALILÉENS DE JUPITER

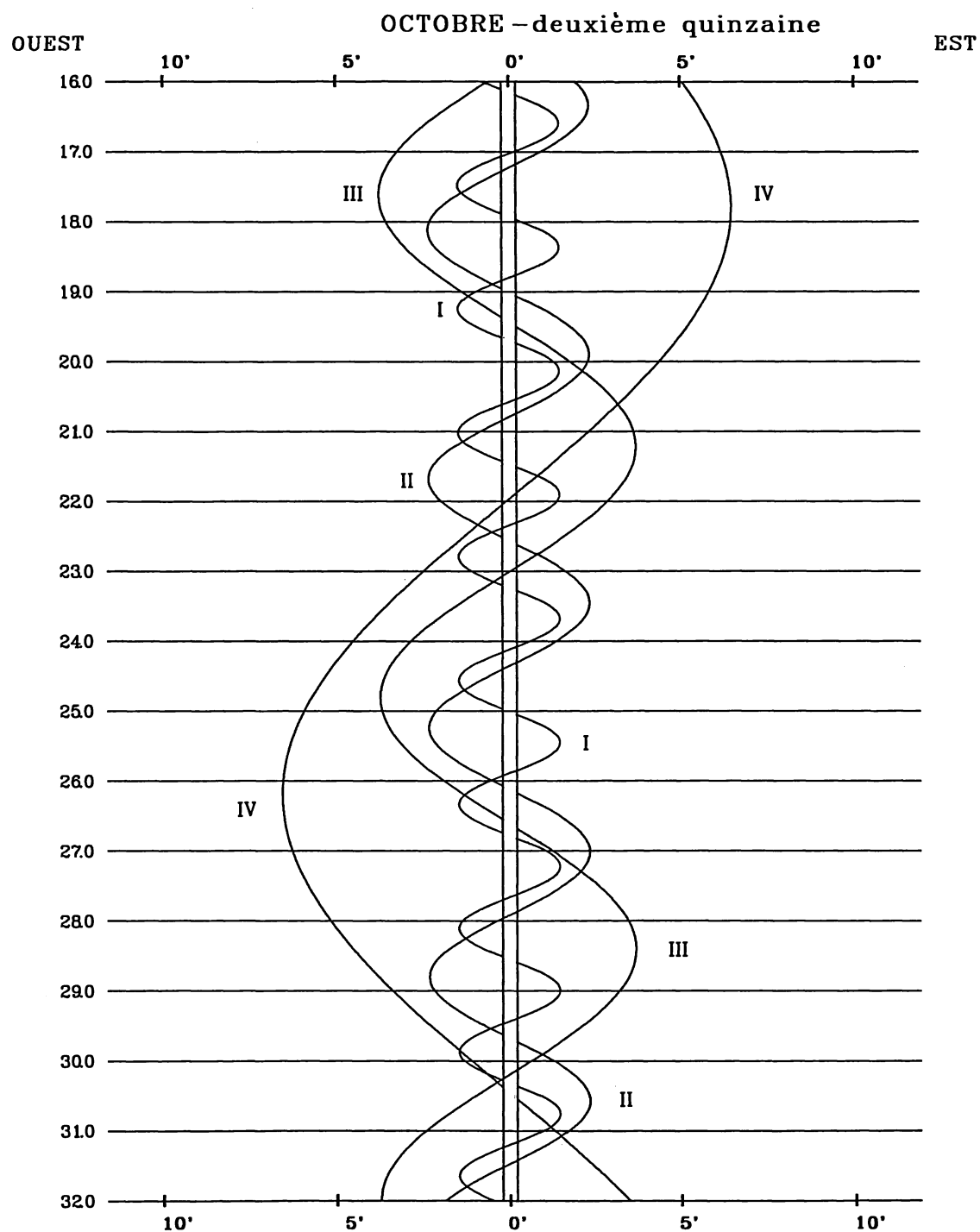

Dans le sens OUEST-EST, les satellites passent au-delà de Jupiter

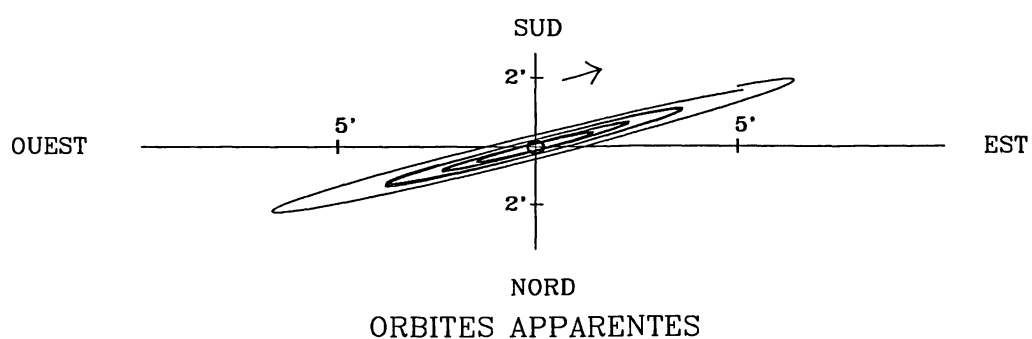

2006 - PHÉNOMÈNES DES SATELLITES GALILÉENS DE JUPITER
(Temps Terrestre)

NOVEMBRE - PREMIÈRE QUINZAINE																		
jour	h	m	s	SAT.	TYPE	jour	h	m	s	SAT.	TYPE	jour	h	m	s	SAT.	TYPE	
1	0	58	6	I	OC.D.EXT	6	7	33	25	III	PA.D.EXT	21	1	36	I	OM.F.INT		
	1	1	54	I	OC.D.INT		7	48	7	III	PA.D.INT	21	5	24	I	OM.F.EXT		
	3	29	53	I	EC.F.INT		8	29	17	I	OC.D.EXT							
	3	33	42	I	EC.F.EXT		8	33	4	I	OC.D.INT	11	2	6	10	II	PA.D.EXT	
	3	34	27	I	EC.F.PEN		8	41	53	III	OM.D.EXT		2	10	33	II	PA.D.INT	
	22	8	11	I	PA.D.EXT		8	57	58	III	OM.D.INT		2	29	5	II	OM.D.EXT	
	22	11	58	I	PA.D.INT		9	40	27	III	PA.F.INT		2	33	31	II	OM.D.INT	
	22	28	21	I	OM.D.EXT		9	55	10	III	PA.F.EXT		4	41	55	II	PA.F.INT	
	22	32	9	I	OM.D.INT		10	39	31	III	OM.F.INT		4	46	17	II	PA.F.EXT	
							10	55	32	III	OM.F.EXT		5	3	44	II	OM.F.INT	
2	0	18	45	I	PA.F.INT		10	55	42	I	EC.F.INT		5	8	9	II	OM.F.EXT	
	0	22	32	I	PA.F.EXT		10	59	31	I	EC.F.EXT		16	0	33	I	OC.D.EXT	
	0	38	48	I	OM.F.INT		11	0	16	I	EC.F.PEN		16	4	20	I	OC.D.INT	
	0	42	35	I	OM.F.EXT								18	21	33	I	EC.F.INT	
	4	10	0	II	OC.D.EXT	7	5	39	2	I	PA.D.EXT		18	25	22	I	EC.F.EXT	
	4	14	18	II	OC.D.INT		5	42	48	I	PA.D.INT		18	26	7	I	EC.F.PEN	
	7	22	36	II	EC.F.INT		5	53	57	I	OM.D.EXT							
	7	27	0	II	EC.F.EXT		5	57	45	I	OM.D.INT	12	13	9	54	I	PA.D.EXT	
	7	28	36	II	EC.F.PEN		7	49	41	I	PA.F.INT		13	13	41	I	PA.D.INT	
	17	32	34	III	OC.D.EXT		7	53	27	I	PA.F.EXT		13	19	30	I	OM.D.EXT	
	17	47	8	III	OC.D.INT		8	4	30	I	OM.F.INT		13	23	17	I	OM.D.INT	
	19	28	27	I	OC.D.EXT		8	8	17	I	OM.F.EXT		15	20	37	I	PA.F.INT	
	19	32	15	I	OC.D.INT		12	40	30	II	PA.D.EXT		15	24	23	I	PA.F.EXT	
	20	47	28	III	EC.F.INT		12	44	52	II	PA.D.INT		15	30	7	I	OM.F.INT	
	21	4	47	III	EC.F.EXT		13	10	45	II	OM.D.EXT		15	33	55	I	OM.F.EXT	
	21	10	1	III	EC.F.PEN		13	15	11	II	OM.D.INT		20	23	17	II	OC.D.EXT	
	21	58	27	I	EC.F.INT		15	16	23	II	PA.F.INT		20	27	36	II	OC.D.INT	
	22	2	17	I	EC.F.EXT		15	20	45	II	PA.F.EXT		23	14	37	II	EC.F.INT	
	22	3	2	I	EC.F.PEN		15	45	26	II	OM.F.INT		23	19	1	II	EC.F.EXT	
							15	49	52	II	OM.F.EXT		23	20	38	II	EC.F.PEN	
3	16	38	29	I	PA.D.EXT	8	2	59	45	I	OC.D.EXT	13	10	30	55	I	OC.D.EXT	
	16	42	16	I	PA.D.INT		3	3	32	I	OC.D.INT		10	34	43	I	OC.D.INT	
	16	56	55	I	OM.D.EXT		5	24	22	I	EC.F.INT		12	1	28	III	PA.D.EXT	
	17	0	43	I	OM.D.INT		5	28	11	I	EC.F.EXT		12	16	15	III	PA.D.INT	
	18	49	5	I	PA.F.INT		5	28	56	I	EC.F.PEN		12	40	6	III	OM.D.EXT	
	18	52	52	I	PA.F.EXT								12	50	7	I	EC.F.INT	
	19	7	24	I	OM.F.INT								12	53	56	I	EC.F.EXT	
	19	11	11	I	OM.F.EXT		9	0	9	18	I	PA.D.EXT		12	54	41	I	EC.F.PEN
	23	15	25	II	PA.D.EXT		0	13	4	I	PA.D.INT		12	56	8	III	OM.D.INT	
	23	19	47	II	PA.D.INT		0	22	27	I	OM.D.EXT		14	7	57	III	PA.F.INT	
	23	52	57	II	OM.D.EXT		0	26	15	I	OM.D.INT		14	22	44	III	PA.F.EXT	
	23	57	23	II	OM.D.INT		2	19	58	I	PA.F.INT		14	28	9	III	OM.F.INT	
4	1	51	25	II	PA.F.INT		2	23	44	I	PA.F.EXT		14	38	9	III	OM.F.EXT	
	1	55	47	II	PA.F.EXT		2	33	1	I	OM.F.INT		14	54	7	III	OM.F.EXT	
	2	27	38	II	OM.F.INT		2	36	49	I	OM.F.EXT							
	2	32	4	II	OM.F.EXT		6	58	48	II	OC.D.EXT	14	7	40	13	I	PA.D.EXT	
	13	58	54	I	OC.D.EXT		7	3	7	II	OC.D.INT		7	44	0	I	PA.D.INT	
	14	2	42	I	OC.D.INT		9	57	18	II	EC.F.INT		7	48	1	I	OM.D.EXT	
	16	27	7	I	EC.F.INT		10	1	43	II	EC.F.EXT		7	51	48	I	OM.D.INT	
	16	30	56	I	EC.F.EXT		10	3	19	II	EC.F.PEN		9	50	57	I	PA.F.INT	
	16	31	41	I	EC.F.PEN		21	30	6	I	OC.D.EXT		9	54	43	I	PA.F.EXT	
5	11	8	45	I	PA.D.EXT		21	33	54	I	OC.D.INT		9	58	40	I	OM.F.INT	
	11	12	31	I	PA.D.INT		22	1	12	III	OC.D.EXT		10	2	27	I	OM.F.EXT	
	11	25	25	I	OM.D.EXT		22	15	49	III	OC.D.INT		15	31	17	II	PA.D.EXT	
	11	29	13	I	OM.D.INT		23	52	56	I	EC.F.INT		15	35	39	II	PA.D.INT	
	13	19	22	I	PA.F.INT		23	56	45	I	EC.F.EXT		15	46	48	II	OM.D.EXT	
	13	23	8	I	PA.F.EXT		23	57	30	I	EC.F.PEN		15	51	14	II	OM.D.INT	
	13	35	56	I	OM.F.INT	10	0	46	57	III	EC.F.INT		18	6	54	II	PA.F.INT	
	13	39	44	I	OM.F.EXT		1	4	11	III	EC.F.EXT		18	11	16	II	PA.F.EXT	
	17	34	19	II	OC.D.EXT		1	9	24	III	EC.F.PEN		18	21	26	II	OM.F.INT	
	17	38	37	II	OC.D.INT		18	39	38	I	PA.D.EXT		18	25	52	II	OM.F.EXT	
	20	39	54	II	EC.F.INT		18	43	24	I	PA.D.INT	15	5	1	23	I	OC.D.EXT	
	20	44	18	II	EC.F.EXT		18	51	0	I	OM.D.EXT		5	5	10	I	OC.D.INT	
	20	45	54	II	EC.F.PEN		18	54	48	I	OM.D.INT		7	18	45	I	EC.F.INT	
							20	50	19	I	PA.F.INT		7	22	34	I	EC.F.EXT	
							20	54	5	I	PA.F.EXT		7	23	19	I	EC.F.PEN	

2006 - PHÉNOMÈNES DES SATELLITES GALILÉENS DE JUPITER
(Temps Terrestre)

NOVEMBRE - DEUXIÈME QUINZAINE																	
jour	h	m	s	SAT.	TYPE	jour	h	m	s	SAT.	TYPE	jour	h	m	s	SAT.	TYPE
16	2	10	30	I	PA.D.EXT		18	36	37	III	PA.F.INT		20	0	25	I	EC.D.EXT
	2	14	16	I	PA.D.INT		18	37	24	III	OM.F.INT		20	4	13	I	EC.D.INT
	2	16	30	I	OM.D.EXT		18	51	29	III	PA.F.EXT		22	14	51	I	OC.F.INT
	2	20	17	I	OM.D.INT		18	53	22	III	OM.F.EXT		22	18	38	I	OC.F.EXT
	4	21	14	I	PA.F.INT												
	4	25	1	I	PA.F.EXT	21	9	41	27	I	PA.D.EXT	26	17	7	28	I	OM.D.EXT
	4	27	10	I	OM.F.INT		9	42	1	I	OM.D.EXT		17	11	16	I	OM.D.INT
	4	30	58	I	OM.F.EXT		9	45	14	I	PA.D.INT		17	12	21	I	PA.D.EXT
	9	47	54	II	OC.D.EXT		9	45	49	I	OM.D.INT		17	16	8	I	PA.D.INT
	9	52	13	II	OC.D.INT		11	52	15	I	PA.F.INT		19	18	16	I	OM.F.INT
	12	32	2	II	EC.F.INT		11	52	46	I	OM.F.INT		19	22	4	I	OM.F.EXT
	12	36	27	II	EC.F.EXT		11	56	1	I	PA.F.EXT		19	23	11	I	PA.F.INT
	12	38	3	II	EC.F.PEN		11	56	33	I	OM.F.EXT		19	26	57	I	PA.F.EXT
	23	31	44	I	OC.D.EXT		18	21	58	II	PA.D.EXT						
	23	35	31	I	OC.D.INT		18	22	39	II	OM.D.EXT	27	1	51	31	II	EC.D.PEN
							18	26	20	II	PA.D.INT		1	53	8	II	EC.D.EXT
17	1	47	17	I	EC.F.INT		18	27	4	II	OM.D.INT		1	57	33	II	EC.D.INT
	1	51	5	I	EC.F.EXT		20	57	12	II	OM.F.INT		4	36	41	II	OC.F.INT
	1	51	50	I	EC.F.PEN		20	57	17	II	PA.F.INT		4	41	2	II	OC.F.EXT
	2	29	20	III	OC.D.EXT		21	1	37	II	OM.F.EXT		14	28	10	I	EC.D.PEN
	2	44	1	III	OC.D.INT		21	1	39	II	PA.F.EXT		14	28	55	I	EC.D.EXT
	4	45	34	III	EC.F.INT								14	32	43	I	EC.D.INT
	5	2	43	III	EC.F.EXT	22	7	2	36	I	EC.D.PEN		16	45	9	I	OC.F.INT
	5	7	54	III	EC.F.PEN		7	2	57	I	OC.D.EXT		16	48	57	I	OC.F.EXT
	20	40	51	I	PA.D.EXT		7	6	44	I	OC.D.INT		20	37	19	III	OM.D.EXT
	20	44	37	I	PA.D.INT		9	14	9	I	OC.F.INT		20	53	10	III	OM.D.INT
	20	45	2	I	OM.D.EXT		9	17	56	I	OC.F.EXT		20	59	21	III	PA.D.EXT
	20	48	50	I	OM.D.INT								21	14	17	III	PA.D.INT
	22	51	36	I	PA.F.INT	23	4	10	29	I	OM.D.EXT		22	36	11	III	OM.F.INT
	22	55	23	I	PA.F.EXT		4	11	44	I	PA.D.EXT		22	52	6	III	OM.F.EXT
	22	55	44	I	OM.F.INT		4	14	16	I	OM.D.INT		23	4	43	III	PA.F.INT
	22	59	32	I	OM.F.EXT		4	15	31	I	PA.D.INT		23	19	40	III	PA.F.EXT
							6	21	14	I	OM.F.INT						
18	4	56	55	II	PA.D.EXT		6	22	32	I	PA.F.INT	28	11	35	58	I	OM.D.EXT
	5	1	17	II	PA.D.INT		6	25	2	I	OM.F.EXT		11	39	46	I	OM.D.INT
	5	5	1	II	OM.D.EXT		6	26	19	I	PA.F.EXT		11	42	40	I	PA.D.EXT
	5	9	27	II	OM.D.INT		12	34	13	II	EC.D.PEN		11	46	26	I	PA.D.INT
	7	32	22	II	PA.F.INT		12	35	49	II	EC.D.EXT		13	46	47	I	OM.F.INT
	7	36	44	II	PA.F.EXT		12	40	14	II	EC.D.INT		13	50	35	I	OM.F.EXT
	7	39	36	II	OM.F.INT		15	12	5	II	OC.F.INT		13	53	30	I	PA.F.INT
	7	44	2	II	OM.F.EXT		15	16	26	II	OC.F.EXT		13	57	17	I	PA.F.EXT
	18	2	9	I	OC.D.EXT								20	58	13	II	OM.D.EXT
	18	5	57	I	OC.D.INT	24	1	31	6	I	EC.D.PEN		21	2	38	II	OM.D.INT
	20	15	52	I	EC.F.INT		1	31	51	I	EC.D.EXT		21	12	22	II	PA.D.EXT
	20	19	41	I	EC.F.EXT		1	35	39	I	EC.D.INT		21	16	44	II	PA.D.INT
	20	20	26	I	EC.F.PEN		3	44	28	I	OC.F.INT		23	32	41	II	OM.F.INT
							3	48	15	I	OC.F.EXT		23	37	6	II	OM.F.EXT
19	15	11	8	I	PA.D.EXT		6	50	29	III	EC.D.PEN		23	47	20	II	PA.F.INT
	15	13	31	I	OM.D.EXT		6	55	40	III	EC.D.EXT		23	51	43	II	PA.F.EXT
	15	14	55	I	PA.D.INT		7	12	6	III	OC.D.INT						
	15	17	18	I	OM.D.INT		9	4	7	III	OC.F.INT	29	8	56	45	I	EC.D.PEN
	17	21	54	I	PA.F.INT		9	18	51	III	OC.F.EXT		8	57	30	I	EC.D.EXT
	17	24	14	I	OM.F.INT		22	39	0	I	OM.D.EXT		9	1	18	I	EC.D.INT
	17	25	41	I	PA.F.EXT		22	42	5	I	PA.D.EXT		11	15	32	I	OC.F.INT
	17	28	2	I	OM.F.EXT		22	42	48	I	OM.D.INT		11	19	19	I	OC.F.EXT
	23	12	28	II	OC.D.EXT		22	45	51	I	PA.D.INT						
	23	16	48	II	OC.D.INT												
20	1	49	21	II	EC.F.INT	25	0	49	47	I	OM.F.INT	30	6	4	25	I	OM.D.EXT
	1	53	46	II	EC.F.EXT		0	52	54	I	PA.F.INT		6	8	13	I	OM.D.INT
	1	55	22	II	EC.F.PEN		0	53	35	I	OM.F.EXT		6	12	55	I	PA.D.EXT
	12	32	31	I	OC.D.EXT		0	56	40	I	PA.F.EXT		6	16	42	I	PA.D.INT
	12	36	18	I	OC.D.INT		7	40	40	II	OM.D.EXT		8	15	15	I	OM.F.INT
	14	44	24	I	EC.F.INT		7	40	40	II	OM.D.EXT		8	19	3	I	OM.F.EXT
	14	48	13	I	EC.F.EXT		7	45	5	II	OM.D.INT		8	23	46	I	PA.F.INT
	14	48	58	I	EC.F.PEN		7	47	26	II	PA.D.EXT		8	27	33	I	PA.F.EXT
	16	30	41	III	PA.D.EXT		7	51	48	II	PA.D.INT		15	8	58	II	EC.D.PEN
	16	39	7	III	OM.D.EXT		10	15	10	II	OM.F.INT		15	10	34	II	EC.D.EXT
	16	45	33	III	PA.D.INT		10	19	35	II	OM.F.EXT		15	14	59	II	EC.D.INT
	16	55	5	III	OM.D.INT		10	22	33	II	PA.F.INT		18	1	27	II	OC.F.INT
							10	26	56	II	PA.F.EXT		18	5	48	II	OC.F.EXT
							19	59	40	I	EC.D.PEN						

2006 – CONFIGURATIONS DES SATELLITES GALILÉENS DE JUPITER

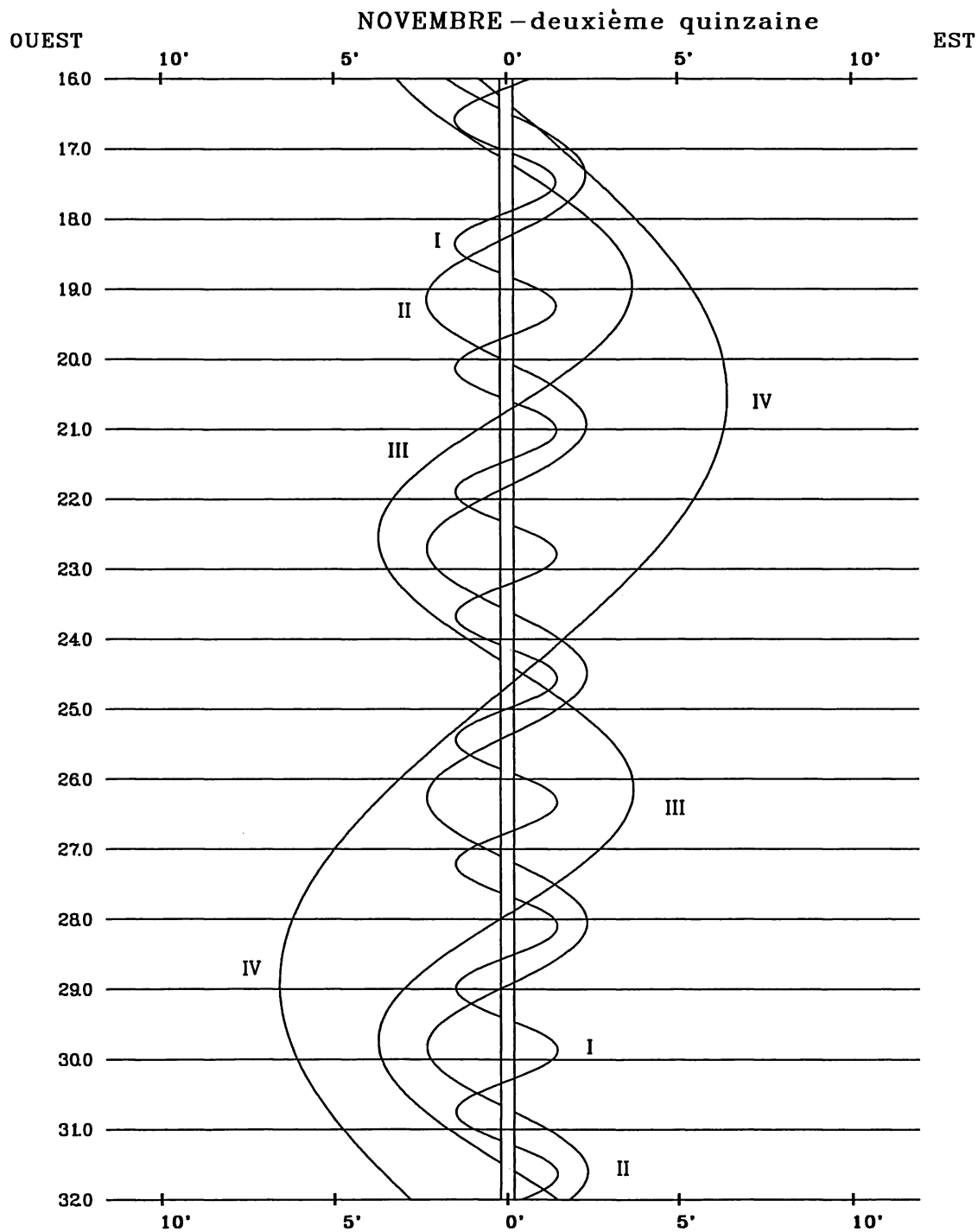

Dans le sens OUEST-EST, les satellites passent au-delà de Jupiter

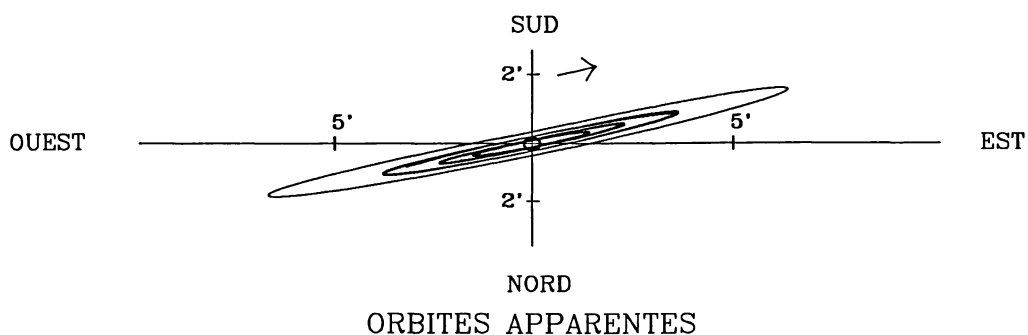

2006 - PHÉNOMÈNES DES SATELLITES GALILÉENS DE JUPITER
(Temps Terrestre)

DÉCEMBRE - PREMIÈRE QUINZAINE																	
jour	h	m	s	SAT.	TYPE	jour	h	m	s	SAT.	TYPE	jour	h	m	s	SAT.	TYPE
1	3	25	13	I	EC.D.PEN		23	33	37	II	OM.D.EXT	11	7	1	3	II	EC.D.PEN
	3	25	58	I	EC.D.EXT		23	38	2	II	OM.D.INT		7	2	40	II	EC.D.EXT
	3	29	46	I	EC.D.INT								7	7	5	II	EC.D.INT
	5	45	49	I	OC.F.INT	6	0	2	24	II	PA.D.EXT		10	15	15	II	OC.F.INT
	5	49	36	I	OC.F.EXT		0	6	47	II	PA.D.INT		10	19	38	II	OC.F.EXT
	10	48	24	III	EC.D.PEN		2	7	59	II	OM.F.INT		18	16	10	I	EC.D.PEN
	10	53	33	III	EC.D.EXT		2	12	23	II	OM.F.EXT		18	16	55	I	EC.D.EXT
	11	10	31	III	EC.D.INT		2	37	1	II	PA.F.INT		18	20	43	I	EC.D.INT
	13	31	40	III	OC.F.INT		2	41	23	II	PA.F.EXT		20	47	26	I	OC.F.INT
	13	46	29	III	OC.F.EXT		10	50	46	I	EC.D.PEN		20	51	13	I	OC.F.EXT
							10	51	31	I	EC.D.EXT						
2	0	32	57	I	OM.D.EXT		10	55	19	I	EC.D.INT	12	4	33	44	III	OM.D.EXT
	0	36	44	I	OM.D.INT		13	16	44	I	OC.F.INT		4	49	25	III	OM.D.INT
	0	43	15	I	PA.D.EXT		13	20	31	I	OC.F.EXT		5	55	32	III	PA.D.EXT
	0	47	2	I	PA.D.INT	7	7	58	20	I	OM.D.EXT		6	10	34	III	PA.D.INT
	2	43	48	I	OM.F.INT		8	2	8	I	OM.D.INT		6	13	33	III	OM.F.INT
	2	47	35	I	OM.F.EXT		8	14	1	I	PA.D.EXT		6	30	33	III	OM.F.EXT
	2	54	6	I	PA.F.INT		8	17	48	I	PA.D.INT		6	49	19	III	OM.F.EXT
	2	57	53	I	PA.F.EXT		8	17	13	I	OM.F.INT		7	59	57	III	PA.F.INT
	10	16	8	II	OM.D.EXT		10	13	1	I	OM.F.EXT		8	14	59	III	PA.F.EXT
	10	20	32	II	OM.D.INT		10	24	53	I	PA.F.INT		15	23	47	I	OM.D.EXT
	10	37	37	II	PA.D.EXT		10	28	40	I	PA.F.EXT		15	27	35	I	OM.D.INT
	10	41	59	II	PA.D.INT		10	28	40	I	PA.F.EXT		15	44	46	I	PA.D.EXT
	12	50	31	II	OM.F.INT		17	43	44	II	EC.D.PEN		15	48	33	I	PA.D.INT
	12	54	56	II	OM.F.EXT		17	45	21	II	EC.D.EXT		17	34	42	I	OM.F.INT
	13	12	23	II	PA.F.INT		17	49	46	II	EC.D.INT		17	38	30	I	OM.F.EXT
	13	16	45	II	PA.F.EXT		20	50	46	II	OC.F.INT		17	55	39	I	PA.F.INT
	21	53	45	I	EC.D.PEN		20	55	8	II	OC.F.EXT		17	59	26	I	PA.F.EXT
	21	54	30	I	EC.D.EXT												
	21	58	18	I	EC.D.INT	8	5	19	13	I	EC.D.PEN	13	2	8	46	II	OM.D.EXT
3	0	16	9	I	OC.F.INT		5	19	58	I	EC.D.EXT		2	13	10	II	OM.D.INT
	0	19	56	I	OC.F.EXT		5	23	46	I	EC.D.INT		2	51	53	II	PA.D.EXT
	19	1	24	I	OM.D.EXT		7	46	58	I	OC.F.INT		2	56	15	II	PA.D.INT
	19	5	12	I	OM.D.INT		7	50	45	I	OC.F.EXT		4	42	59	II	OM.F.INT
	19	13	30	I	PA.D.EXT		14	46	22	III	EC.D.PEN		4	47	23	II	OM.F.EXT
	19	17	17	I	PA.D.INT		14	51	31	III	EC.D.EXT		5	26	6	II	PA.F.INT
	21	12	16	I	OM.F.INT		15	8	24	III	EC.D.INT		5	30	29	II	PA.F.EXT
	21	16	3	I	OM.F.EXT		17	59	4	III	OC.F.INT		12	44	41	I	EC.D.PEN
	21	24	22	I	PA.F.INT		18	13	55	III	OC.F.EXT		12	45	26	I	EC.D.EXT
	21	28	8	I	PA.F.EXT								12	49	14	I	EC.D.INT
4	4	26	15	II	EC.D.PEN		2	30	39	I	OM.D.EXT		15	17	42	I	OC.F.INT
	4	27	52	II	EC.D.EXT		2	44	19	I	PA.D.EXT		15	21	29	I	OC.F.EXT
	4	32	17	II	EC.D.INT		2	48	6	I	PA.D.INT						
	7	26	0	II	OC.F.INT		4	37	45	I	OM.F.INT	14	9	52	13	I	OM.D.EXT
	7	30	21	II	OC.F.EXT		4	41	33	I	OM.F.EXT		9	56	0	I	OM.D.INT
	16	22	13	I	EC.D.PEN		4	55	11	I	PA.F.INT		10	14	57	I	PA.D.EXT
	16	22	58	I	EC.D.EXT		4	58	58	I	PA.F.EXT		10	18	44	I	PA.D.INT
	16	26	47	I	EC.D.INT		12	51	22	II	OM.D.EXT		12	3	8	I	OM.F.INT
	18	46	25	I	OC.F.INT		12	55	46	II	OM.D.INT		12	6	56	I	OM.F.EXT
	18	50	12	I	OC.F.EXT		13	27	21	II	PA.D.EXT		12	25	49	I	PA.F.INT
							13	31	43	II	PA.D.INT		12	29	36	I	PA.F.EXT
5	0	35	54	III	OM.D.EXT		15	25	38	II	OM.F.INT		20	18	38	II	EC.D.PEN
	0	51	41	III	OM.D.INT		15	30	3	II	OM.F.EXT		20	20	15	II	EC.D.EXT
	1	28	2	III	PA.D.EXT		16	1	45	II	PA.F.INT		20	24	40	II	EC.D.INT
	1	43	1	III	PA.D.INT		16	6	7	II	PA.F.EXT		23	40	2	II	OC.F.INT
	2	35	15	III	OM.F.INT		23	47	43	I	EC.D.PEN		23	44	24	II	OC.F.EXT
	2	51	6	III	OM.F.EXT		23	48	28	I	EC.D.EXT						
	3	32	55	III	PA.F.INT		23	52	16	I	EC.D.INT	15	7	13	6	I	EC.D.PEN
	3	47	54	III	PA.F.EXT								7	13	51	I	EC.D.EXT
	13	29	54	I	OM.D.EXT	10	2	17	14	I	OC.F.INT		7	17	39	I	EC.D.INT
	13	33	41	I	OM.D.INT		2	21	1	I	OC.F.EXT		9	47	52	I	OC.F.INT
	13	43	47	I	PA.D.EXT		20	55	18	I	OM.D.EXT		9	51	39	I	OC.F.EXT
	13	47	34	I	PA.D.INT		20	59	5	I	OM.D.INT		18	45	4	III	EC.D.PEN
	15	40	46	I	OM.F.INT		21	14	31	I	PA.D.EXT		18	50	12	III	EC.D.EXT
	15	44	34	I	OM.F.EXT		21	18	18	I	PA.D.INT		19	6	59	III	EC.D.INT
	15	54	39	I	PA.F.INT		23	6	12	I	OM.F.INT		22	26	43	III	OC.F.INT
	15	58	26	I	PA.F.EXT		23	10	0	I	OM.F.EXT		22	41	37	III	OC.F.EXT
							23	25	24	I	PA.F.INT						

2006 - CONFIGURATIONS DES SATELLITES GALILÉENS DE JUPITER

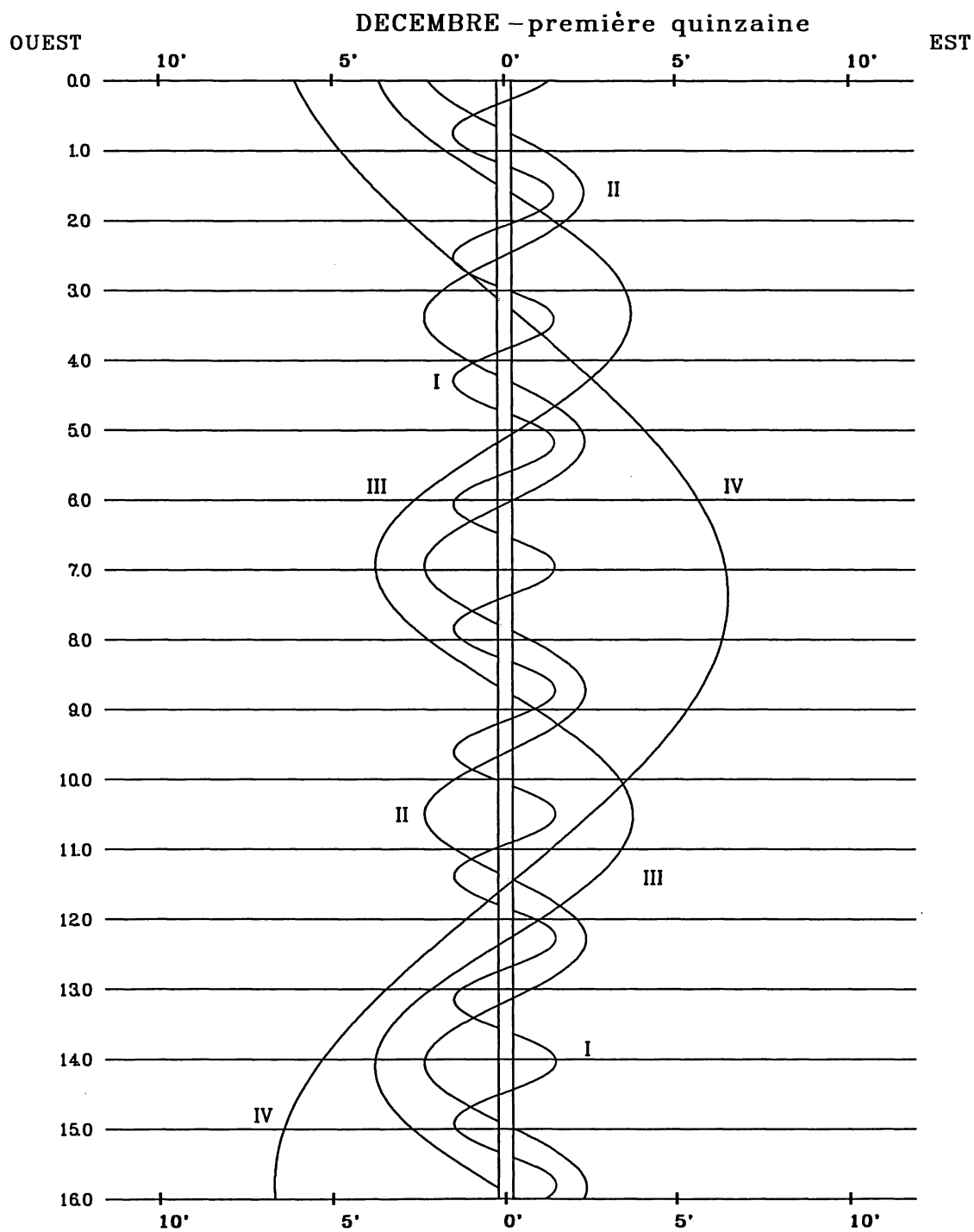

Dans le sens OUEST-EST, les satellites passent au-delà de Jupiter

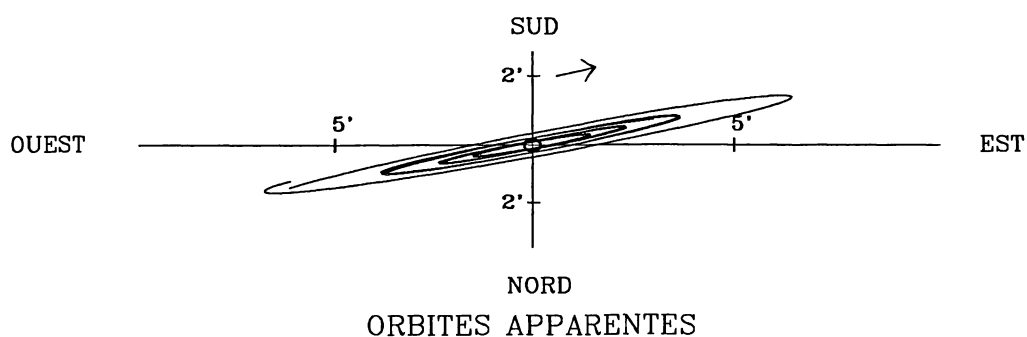

2006 - PHÉNOMÈNES DES SATELLITES GALILÉENS DE JUPITER
(Temps Terrestre)

DÉCEMBRE - DEUXIÈME QUINZAINE																					
jour	h	m	s	SAT.	TYPE	jour	h	m	s	SAT.	TYPE	jour	h	m	s	SAT.	TYPE				
16	4	20	43	I	OM.D.EXT	22	22	55	10	II	EC.D.EXT	28	8	28	52	II	PA.D.EXT				
	4	24	31	I	OM.D.INT		22	22	59	35	II		EC.D.INT	8	33	14	II	PA.D.INT			
	4	45	12	I	PA.D.EXT		22	2	29	1	II		OC.F.INT	9	52	18	II	OM.F.INT			
	4	48	59	I	PA.D.INT			2	33	24	II		OC.F.EXT	9	56	42	II	OM.F.EXT			
	6	31	39	I	OM.F.INT			2	33	24	II		OC.F.EXT	11	2	17	II	PA.F.INT			
	6	35	27	I	OM.F.EXT			9	6	51	I		EC.D.PEN	11	6	40	II	PA.F.EXT			
	6	56	5	I	PA.F.INT			9	7	36	I		EC.D.EXT	16	32	8	I	EC.D.PEN			
	6	59	52	I	PA.F.EXT			9	11	24	I		EC.D.INT	16	32	53	I	EC.D.EXT			
	15	26	22	II	OM.D.EXT			11	48	27	I		OC.F.INT	16	36	41	I	EC.D.INT			
	15	30	46	II	OM.D.INT			11	52	14	I		OC.F.EXT	19	18	41	I	OC.F.INT			
	16	16	30	II	PA.D.EXT			22	43	2	III		EC.D.PEN	19	22	28	I	OC.F.EXT			
	16	20	52	II	PA.D.INT			22	48	8	III		EC.D.EXT	28	13	39	52	I	OM.D.EXT		
	18	0	30	II	OM.F.INT			23	4	49	III		EC.D.INT		13	43	40	I	OM.D.INT		
	18	4	54	II	OM.F.EXT			23	0	38	40		III		EC.F.INT	14	16	8	I	PA.D.EXT	
	18	50	30	II	PA.F.INT				0	47	42		III		OC.D.EXT	14	19	55	I	PA.D.INT	
	18	54	53	II	PA.F.EXT				0	55	22		III		EC.F.EXT	15	50	49	I	OM.F.INT	
	17	1	41	34	I				EC.D.PEN	1	0		28		III	EC.F.PEN	15	54	37	I	OM.F.EXT
		1	42	19	I				EC.D.EXT	1	2		38		III	OC.D.INT	16	26	59	I	PA.F.INT
1		46	7	I	EC.D.INT	2			52	54	III	OC.F.INT	16		30	46	I	PA.F.EXT			
4		18	4	I	OC.F.INT	3			7	50	III	OC.F.EXT	29		1	28	33	II	EC.D.PEN		
4		21	50	I	OC.F.EXT	6	14		34	I	OM.D.EXT	1			30	10	II	EC.D.EXT			
22		49	10	I	OM.D.EXT	6	18		22	I	OM.D.INT	1			34	36	II	EC.D.INT			
22		52	57	I	OM.D.INT	6	45		52	I	PA.D.EXT	5			17	40	II	OC.F.INT			
23		15	22	I	PA.D.EXT	6	49		40	I	PA.D.INT	5			22	4	II	OC.F.EXT			
23		19	9	I	PA.D.INT	8	25		31	I	OM.F.INT	11			0	30	I	EC.D.PEN			
18		1	0	5	I	OM.F.INT	8		29	18	I	OM.F.EXT			11	1	15	I	EC.D.EXT		
		1	3	53	I	OM.F.EXT	8		56	44	I	PA.F.INT			11	5	3	I	EC.D.INT		
	1	26	14	I	PA.F.INT	9	0		31	I	PA.F.EXT	13			48	41	I	OC.F.INT			
	1	30	1	I	PA.F.EXT	18	1		12	II	OM.D.EXT	13			52	27	I	OC.F.EXT			
	9	35	55	II	EC.D.PEN	18	5		35	II	OM.D.INT	30		2	41	15	III	EC.D.PEN			
	9	37	32	II	EC.D.EXT	19	5		1	II	PA.D.EXT		2	46	20	III	EC.D.EXT				
	9	41	58	II	EC.D.INT	19	9	23	II	PA.D.INT	3		2	54	III	EC.D.INT					
	13	4	22	II	OC.F.INT	20	35	10	II	OM.F.INT	4		37	33	III	EC.F.INT					
	13	8	45	II	OC.F.EXT	20	39	33	II	OM.F.EXT	4		54	8	III	EC.F.EXT					
	20	9	59	I	EC.D.PEN	21	38	37	II	PA.F.INT	4		59	13	III	EC.F.PEN					
	20	10	44	I	EC.D.EXT	21	42	59	II	PA.F.EXT	5		13	18	III	OC.D.EXT					
	20	14	32	I	EC.D.INT	24	3	35	18	I	EC.D.PEN		5	28	15	III	OC.D.INT				
	22	48	12	I	OC.F.INT		3	36	3	I	EC.D.EXT		7	18	18	III	OC.F.INT				
	22	51	58	I	OC.F.EXT		3	39	50	I	EC.D.INT		7	33	14	III	OC.F.EXT				
19	8	31	23	III	OM.D.EXT		6	18	34	I	OC.F.INT		8	8	22	I	OM.D.EXT				
	8	47	0	III	OM.D.INT		6	22	20	I	OC.F.EXT	8	12	10	I	OM.D.INT					
	10	22	12	III	PA.D.EXT		25	0	43	0	I	OM.D.EXT	8	46	15	I	PA.D.EXT				
	10	31	41	III	OM.F.INT			0	46	47	I	OM.D.INT	8	50	2	I	PA.D.INT				
	10	37	17	III	PA.D.INT			1	15	58	I	PA.D.EXT	10	19	19	I	OM.F.INT				
	10	47	23	III	OM.F.EXT			1	19	45	I	PA.D.INT	10	23	7	I	OM.F.EXT				
	12	26	12	III	PA.F.INT			2	53	56	I	OM.F.INT	10	57	5	I	PA.F.INT				
	12	41	15	III	PA.F.EXT			2	57	44	I	OM.F.EXT	11	0	52	I	PA.F.EXT				
	17	17	38	I	OM.D.EXT	3		26	49	I	PA.F.INT	20	35	46	II	OM.D.EXT					
	17	21	26	I	OM.D.INT	3		30	36	I	PA.F.EXT	20	40	8	II	OM.D.INT					
	17	45	34	I	PA.D.EXT	12		10	50	II	EC.D.PEN	21	52	40	II	PA.D.EXT					
	17	49	21	I	PA.D.INT	12		12	27	II	EC.D.EXT	21	57	2	II	PA.D.INT					
	19	28	35	I	OM.F.INT	12		16	53	II	EC.D.INT	23	9	33	II	OM.F.INT					
19	32	23	I	OM.F.EXT	15	53		9	II	OC.F.INT	23	13	57	II	OM.F.EXT						
19	56	26	I	PA.F.INT	15	57		33	II	OC.F.EXT	31	0	25	52	II	PA.F.INT					
20	0	13	I	PA.F.EXT	22	3	41	I	EC.D.PEN	0		30	14	II	PA.F.EXT						
20	4	43	42	II	OM.D.EXT	22	4	26	I	EC.D.EXT		5	28	55	I	EC.D.PEN					
	4	48	6	II	OM.D.INT	22	8	14	I	EC.D.INT		5	29	40	I	EC.D.EXT					
	5	40	45	II	PA.D.EXT	26	0	48	36	I		OC.F.INT	5	33	27	I	EC.D.INT				
	5	45	8	II	PA.D.INT		0	52	23	I		OC.F.EXT	8	18	41	I	OC.F.INT				
	7	17	46	II	OM.F.INT		12	29	9	III		OM.D.EXT	8	22	27	I	OC.F.EXT				
	7	22	10	II	OM.F.EXT		12	44	41	III		OM.D.INT	32	2	36	47	I	OM.D.EXT			
	8	14	35	II	PA.F.INT		14	29	54	III		OM.F.INT		2	40	35	I	OM.D.INT			
	8	18	57	II	PA.F.EXT		14	45	31	III		OM.F.EXT		3	16	16	I	PA.D.EXT			
	14	38	28	I	EC.D.PEN		14	48	6	III		PA.D.EXT		3	20	3	I	PA.D.INT			
	14	39	13	I	EC.D.EXT		15	3	14	III	PA.D.INT	4		47	44	I	OM.F.INT				
	14	43	1	I	EC.D.INT		16	51	41	III	PA.F.INT	4		51	32	I	OM.F.EXT				
	17	18	22	I	OC.F.INT		17	6	46	III	PA.F.EXT	5		27	5	I	PA.F.INT				
	17	22	9	I	OC.F.EXT		19	11	28	I	OM.D.EXT	5		30	52	I	PA.F.EXT				
	21	11	46	4	I		OM.D.EXT	19	15	16	I	OM.D.INT		14	45	52	II	EC.D.PEN			
11		49	51	I	OM.D.INT		19	46	6	I	PA.D.EXT	14		47	29	II	EC.D.EXT				
12		15	41	I	PA.D.EXT		19	49	53	I	PA.D.INT	14		51	55	II	EC.D.INT				
12		19	28	I	PA.D.INT	21	22	25	I	OM.F.INT	18	41	33	II	OC.F.INT						
13		57	0	I	OM.F.INT	21	26	13	I	OM.F.EXT	18	45	57	II	OC.F.EXT						
14		0	48	I	OM.F.EXT	21	56	57	I	PA.F.INT	23	57	17	I	EC.D.PEN						
14		26	33	I	PA.F.INT	22	0	44	I	PA.F.EXT	23	58	1	I	EC.D.EXT						
14		30	20	I	PA.F.EXT	27	7	18	25	II	OM.D.EXT										
17		53	32	II	EC.D.PEN		7	22	48	II	OM.D.INT										

2006 - CONFIGURATIONS DES SATELLITES GALILÉENS DE JUPITER

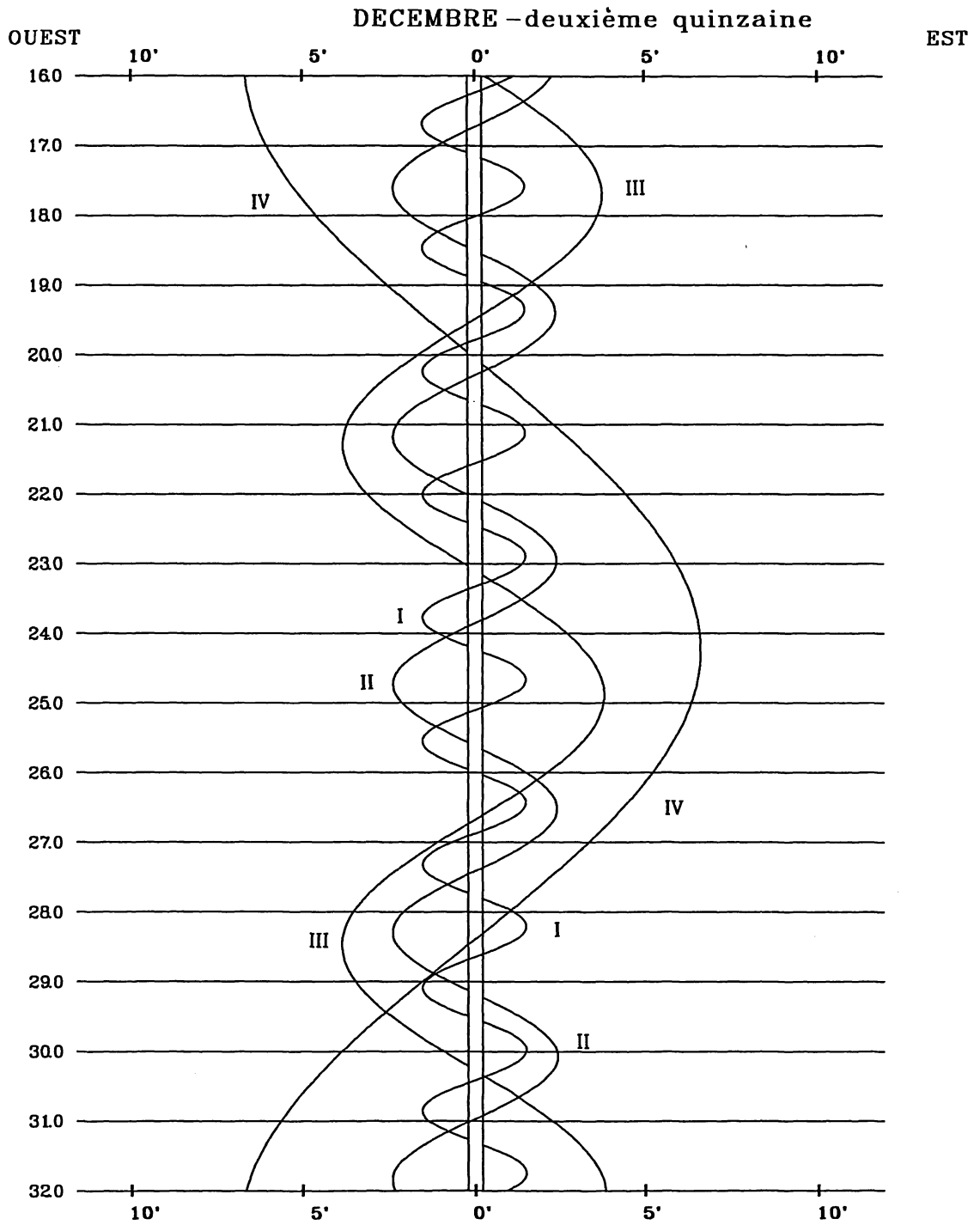

Dans le sens OUEST-EST, les satellites passent au-delà de Jupiter

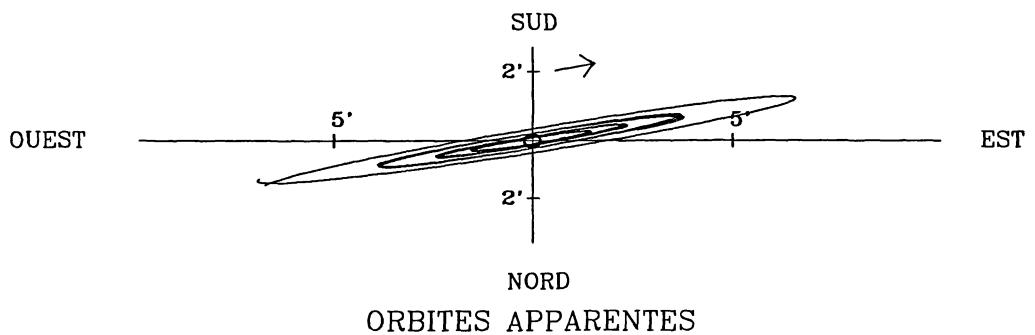

PHÉNOMÈNES POUR 2007

PHENOMENA FOR 2007

LES PHÉNOMÈNES POUR 2007

Pour l'année 2007, les phénomènes sont donnés par l'intermédiaire de coefficients d'un polynôme. On a ainsi une représentation sous une forme très condensée. La précision est cependant moins bonne que celle des prédictions des phénomènes pour 2006. Cette précision et la méthode pour déterminer les phénomènes sont données ci-après.

UTILISATION DES COEFFICIENTS

Soit P la période synodique moyenne d'un satellite; la date approchée T_1 du phénomène proche de la date T est donnée par la relation :

$$T_1 = KP + \tau/24 + T_0 \quad (1)$$

où K représente la partie entière de la quantité $(T - T_0)/P$ et où τ est donné, sur l'intervalle $(T_0, T_0 + DT)$ par un polynôme de la forme :

$$\tau = C_0 + C_1x + C_2x^2 + \dots + C_nx^n \quad (2)$$

avec

$$x = [2(T - T_0)/DT] - 1 \quad (3)$$

T_1 ayant été obtenu par la relation (1), on peut réitérer le calcul en substituant T_1 à T dans la formule (3) pour obtenir une date T_2 plus proche du phénomène recherché que T_1 . La précision de ce type de prédiction est meilleure que 60 secondes de temps.

Les tables donnent les coefficients C_i de la formule (2), numérotés à partir de C_0 pour les quatre satellites et pour les phénomènes:

- débuts et fins des éclipses des satellites par Jupiter (notés EC.D et EC.F),
- débuts et fins des occultations des satellites par Jupiter (notés OC.D et OC.F),
- débuts et fins des passages de l'ombre des satellites sur le disque de Jupiter (OM.D et OM.F),
- débuts et fins des passages des satellites devant la planète (PA.D et PA.F).

PHENOMENA FOR 2007

For 2007, the phenomena are given using polynomial coefficients. So, we have a compact representation. However, the accuracy is less than the one from the data given for 2006. This accuracy and the method of calculation of the phenomena are given here after.

USE OF THE COEFFICIENTS

Let P be the mean synodique period of a satellite; the approximate date T_1 of a phenomenon close to a date T is given by :

$$T_1 = KP + \tau/24 + T_0 \quad (1)$$

where K is the integer part of $(T - T_0)/P$ and where τ is given on the interval $(T_0, T_0 + DT)$ by a polynomial :

$$\tau = C_0 + C_1x + C_2x^2 + \dots + C_nx^n \quad (2)$$

with

$$x = [2(T - T_0)/DT] - 1 \quad (3)$$

The value T_1 deduced from equation (1) is then substituted in place of T in equation (3). The new iteration yields a date T_2 closer to the date of the phenomenon than T_1 . The precision of this type of prediction is better than 60 seconds of time.

The tables give the coefficients C_i in formula (2) numbered from C_0 for the four satellites and for the following phenomena:

- disappearance and reappearance of the satellites eclipsed by Jupiter (denoted respectively by EC.D and EC.F),
- disappearance and reappearance of the satellites occulted by Jupiter (denoted OC.D and OC.F),
- ingress and egress of the transits of the satellites shadow across the disc of Jupiter (OM.D and OM.F),
- ingress and egress of the satellites transits across the planet (PA.D and PA.F).

EXEMPLE D'UTILISATION

Déterminons les dates des phénomènes du satellite I (Io) au voisinage du 30 juin 2007.

Voyons tout d'abord le calcul pour le début d'éclipse pour lequel les tables donnent :

$$T_0 = 0; P = 1,7698605; DT = 366$$

Du 0 janvier au 30 juin 2007, 181 jours se sont écoulés, on a donc $T = 181$ et la formule (3) donne alors :

$$x = 2(181 - 0)/366 - 1 = -0,01092896$$

La formule (2) donne ensuite :

$\begin{aligned} \tau &= 5.068981 & - & 0.010835 & x & + & 0.683224 & x^2 \\ & - & 0.089489 & x^3 & - & 0.330244 & x^4 \end{aligned}$

d'où : $\tau = 5,069181$

On a d'autre part :

$$K = \text{partie entière de } (181 - 0)/1,7698605 \\ = 102$$

La formule (1) donne alors :

$$\begin{aligned} T_1 &= 102 \times 1,7698605 + 5,069181/24 + 0 \\ T_1 &= 180,736987 \text{ jours} \end{aligned}$$

depuis le 0 janvier (début de l'intervalle pour les éclipses) soit EC.D le 29 juin 2007 à 17h 41m 16s TT. Le calcul réitéré donne $T_2 = 180,736989$ jours soit le 29 juin 2007 à 17h 41m 16s TT.

On trouverait de même pour les autres phénomènes :

OC.D	le 29 juin	à 17h 08m 10s
OC.F	le 29 juin	à 19h 19m 09s
EC.F	le 29 juin	à 19h 53m 02s
PA.D	le 30 juin	à 14h 27m 41s
OM.D	le 30 juin	à 15h 01m 49s
PA.F	le 30 juin	à 16h 38m 36s
OM.F	le 30 juin	à 17h 13m 11s

EXAMPLE

Let us find the dates of the phenomena of satellite I (Io) which take place near the 30th of June 2007.

Let us start with the computation of the disappearance for the eclipse of the satellite for which the tables gives :

$$T_0 = 0; P = 1.7698605; DT = 366$$

Between January 0 to June the 30th 2007, 181 days have elapsed : $T = 181$ and formula (3) gives :

$$x = 2(181 - 0)/366 - 1 = -0.01092896$$

Formula (2) then gives:

therefore $\tau = 5.069181$

On the other hand :

$$K = \text{integer part of } (181 - 0)/1.7698605 \\ = 102$$

Formula (1) then gives :

$$\begin{aligned} T_1 &= 102 \times 1.7698605 + 5.069181/24 + 0 \\ T_1 &= 180.736987 \text{ days} \end{aligned}$$

from January 0 (beginning of the interval for the occultations) that is June the 29th 2007 at 17h 41m 16s TT. Another iteration gives $T_2 = 180.736989$ days that is June the 29th 2007 at 17h 41m 16s TT.

One would find as well for the other phenomena:

<i>OC.D</i>	<i>June the 29th</i>	<i>at 17h 08m 10s</i>
<i>OC.F</i>	<i>June the 29th</i>	<i>at 19h 19m 09s</i>
<i>EC.F</i>	<i>June the 29th</i>	<i>at 19h 53m 02s</i>
<i>PA.D</i>	<i>June the 30th</i>	<i>at 14h 27m 41s</i>
<i>OM.D</i>	<i>June the 30th</i>	<i>at 15h 01m 49s</i>
<i>PA.F</i>	<i>June the 30th</i>	<i>at 16h 38m 36s</i>
<i>OM.F</i>	<i>June the 30th</i>	<i>at 17h 13m 11s</i>

CONDITIONS D'EXISTENCE DES PHÉNOMÈNES

Le recouvrement des cônes d'ombre et de visibilité rend inexistants certains phénomènes. Ainsi avant (ou après) l'opposition de Jupiter, les fins (respectivement débuts) d'éclipse et les débuts (respectivement fins) d'occultations sont inobservables. Ceci ne pouvant être pris en compte dans la représentation, il est nécessaire que l'utilisateur vérifie les conditions d'existence pour les éclipses et les occultations en calculant les quatre phases EC.D, EC.F, OC.D et OC.F. Ainsi, dans l'exemple précédent, on a dans l'ordre chronologique :

OC.D le 29 juin à 17h 8m 10s observable

EC.D le 29 juin à 17h 41m 16s inobservable car occulté

OC.F le 29 juin à 19h 19m 9s inobservable car déjà éclipsé

EC.F le 29 juin à 19h 53m 2s observable.

D'autre part, les caractéristiques de l'orbite du satellite IV (Callisto) font qu'il n'existe pas toujours de phénomènes. Les coefficients relatifs à ce satellite ne sont donc donnés que sur l'intervalle où ils existent.

CONDITIONS FOR THE EXISTENCE OF THE PHENOMENA

As the visibility and shadow cones may sometimes overlap, some of the computed phenomena may not exist. Thus, before (or after) the opposition of Jupiter, the reappearances (respectively the disappearances) for the eclipses, and the disappearances (respectively reappearances) for the occultations are not observable. This could not be taken into account in the representation; so the user will have to check the existence conditions of the eclipses and occultations by computing the four steps EC.D, EC.F, OC.D and OC.F. For instance, in the example above one has, in chronological order :

OC.D June 29th at 17h 8m 10s observable

EC.D June 29th at 17h 41m 16s unobservable as occulted

OC.F June 29th at 19h 19m 9s unobservable as eclipsed

EC.F June 29th at 19h 53m 2s observable.

Moreover, the orbit of satellite IV (Callisto) is such that phenomena are not always present. The coefficients for this satellite are given on the interval for which they exist.

**2007- COEFFICIENTS DES PHÉNOMÈNES
DES SATELLITES GALILÉENS DE JUPITER**

SATELLITE 1		P = 1.7698605	T0 = 0		DT = 366jours	
	EC.D		EC.F		OM.D	OM.F
0	5.068981	0	7.265702	0	26.412256	0 28.601763
1	-0.010835	1	0.039902	1	0.057966	1 0.070205
2	0.683224	2	0.695338	2	0.379696	2 0.350105
3	-0.089489	3	-0.105767	3	-0.143393	3 -0.123248
4	-0.330244	4	-0.334034	4	-0.220019	4 -0.181458
	OC.D		OC.F		PA.D	PA.F
0	4.469328	0	6.654933	0	25.814741	0 27.998348
1	-3.804450	1	-3.750573	1	-3.667477	1 -3.687202
2	4.350306	2	4.412548	2	4.223418	2 4.150386
3	6.705109	3	6.646173	3	6.453256	3 6.641278
4	-6.656311	4	-6.747068	4	-7.158407	4 -6.881891
5	-4.690949	5	-4.622649	5	-4.497283	5 -4.751855
6	5.615891	6	5.697213	6	6.314838	6 6.029951
7	1.455259	7	1.424332	7	1.393370	7 1.506334
8	-1.962127	8	-1.990247	8	-2.230886	8 -2.130581

TO = 0 correspond au 0 janvier 2007 à 0h soit la date julienne 2454100.5

SATELLITE 2		P = 3.5540942	T0 = 0		DT = 366jours	
	EC.D		EC.F		OM.D	OM.F
0	38.841026	0	41.431303	0	80.995911	0 83.562208
1	0.135106	1	0.151905	1	-0.243659	1 -0.148536
2	-0.212314	2	-0.212759	2	1.379708	2 1.386201
3	-0.274324	3	-0.243243	3	0.037669	3 0.013276
4	0.059899	4	0.068159	4	-0.641308	4 -0.610955
SATELLITE 2		P= 3.5540942jours		T0= -1	DT= 366jours	
	OC.D		OC.F		PA.D	PA.F
0	61.669499	0	64.237367	0	18.541358	0 21.086723
1	-7.698046	1	-7.575322	1	-8.050518	1 -7.924408
2	7.729641	2	7.803916	2	8.738912	2 8.724070
3	14.895538	3	14.480706	3	15.089444	3 15.098418
4	-16.779855	4	-16.893539	4	-16.442828	4 -16.136288
5	-14.018709	5	-13.233374	5	-13.292461	5 -13.537864
6	22.189045	6	22.346056	6	21.841902	6 21.385526
7	8.657373	7	7.988780	7	7.471408	7 7.762775
8	-16.265741	8	-16.371894	8	-16.690137	8 -16.348196
9	-2.464794	9	-2.246895	9	-1.910678	9 -2.026971
10	4.913474	10	4.944651	10	5.212929	10 5.102788

TO = 0 correspond au 0 janvier 2007 à 0h soit la date julienne 2454100.5

**2007- COEFFICIENTS DES PHÉNOMÈNES
DES SATELLITES GALILÉENS DE JUPITER**

SATELLITE 3		P = 7.1663872		TO = 0		DT = 366jours	
EC.D		EC.F		OM.D		OM.F	
0	149.972860	0	152.291761	0	63.926566	0	66.216363
1	-0.403973	1	0.030710	1	-0.328731	1	0.088871
2	0.641158	2	0.690734	2	0.486062	2	0.508813
3	-0.163750	3	-0.185117	3	-0.306353	3	-0.230032
4	-0.292869	4	-0.292259	4	-0.253707	4	-0.215290
5	0.048707	5	0.046145	5	0.161748	5	0.086651
OC.D		OC.F		PA.D		PA.F	
0	147.592294	0	149.758375	0	61.538878	0	63.674736
1	-16.210548	1	-15.456515	1	-16.155315	1	-15.423986
2	16.506323	2	17.137274	2	16.585811	2	17.099282
3	31.591042	3	29.395442	3	31.209570	3	29.256738
4	-36.999609	4	-37.670796	4	-38.057761	4	-38.159679
5	-33.015272	5	-27.330963	5	-31.633215	5	-26.491125
6	61.667967	6	61.572388	6	64.126467	6	62.728238
7	26.866125	7	19.019624	7	25.250976	7	17.928356
8	-68.439668	8	-67.103391	8	-71.508203	8	-68.305214
9	-13.722572	9	-8.175716	9	-13.631199	9	-8.288738
10	42.809582	10	41.459454	10	44.815705	10	41.992446
11	2.995638	11	1.422002	11	3.518120	11	1.956283
12	-11.248821	12	-10.814071	12	-11.771043	12	-10.866295

TO = 0 correspond au 0 janvier 2007 à 0h soit la date julienne 2454100.5

SATELLITE 4		P = 16.7535520		TO = 350		DT = 50jours	
EC.D		EC.F		OM.D		OM.F	
0	175.879401	0	176.872166	0	375.208112	0	375.913147
1	-0.479736	1	0.361759	1	-0.591513	1	0.491305
2	0.101540	2	-0.121021	2	0.108038	2	-0.117565
3	-0.017574	3	0.023590	3	0.000000	3	0.000000
4	0.000413	4	-0.000508	4	0.000000	4	0.000000
OC.D		OC.F		PA.D		PA.F	
0	178.491929	0	180.076448	0	377.725405	0	379.219688
1	3.499204	1	4.436105	1	3.523911	1	4.470202
2	0.009522	2	-0.299449	2	-0.019674	2	-0.260720
3	-0.117561	3	0.004124	3	-0.091008	3	-0.046083
4	0.006913	4	-0.019666	4	-0.000118	4	-0.000027

TO = 0 correspond au 0 janvier 2007 à 0h soit la date julienne 2454100.5

